



7PZ IP



User Manual

©2023 ADJ Products, LLC all rights reserved. Information, specifications, diagrams, images, and instructions herein are subject to change without notice. ADJ Products, LLC logo and identifying product names and numbers herein are trademarks of ADJ Products, LLC. Copyright protection claimed includes all forms and matters of copyrightable materials and information now allowed by statutory or judicial law or hereinafter granted. Product names used in this document may be trademarks or registered trademarks of their respective companies and are hereby acknowledged. All non-ADJ Products, LLC brands and product names are trademarks or registered trademarks of their respective companies.

ADJ Products, LLC and all affiliated companies hereby disclaim any and all liabilities for property, equipment, building, and electrical damages, injuries to any persons, and direct or indirect economic loss associated with the use or reliance of any information contained within this document, and/or as a result of the improper, unsafe, insufficient and negligent assembly, installation, rigging, and operation of this product.

ADJ PRODUCTS LLC World Headquarters

6122 S. Eastern Ave. | Los Angeles, CA 90040 USA

Tel: 800-322-6337 | Fax: 323-582-2941 | www.adj.com | support@adj.com

ADJ Supply Europe B.V.

Junostraat 2 | 6468 EW Kerkrade | Netherlands

Tel: +31 45 546 85 00 | Fax: +31 45 546 85 99 | www.americandj.eu | service@americandj.eu



DOCUMENT VERSION

Due to additional product features and/or enhancements, an updated version of this document may be available online.

Please check www.adj.com for the latest revision/update of this manual before beginning installation and/or programming.

Date	Document Version	Software Version	DMX Channel Mode	Notes
9/07/20	1.0	N/A	N/A	Initial Release
01/27/21	1.05	N/A	N/A	Updated Software
11/29/23	1.1	N/A	N/A	Updated Specifications

Europe Energy Saving Notice

Energy Saving Matters (EuP 2009/125/EC)

Saving electric energy is a key to help protecting the environment. Please turn off all electrical products when they are not in use. To avoid power consumption in idle mode, disconnect all electrical equipment from power when not in use. Thank you!

GENERAL INFORMATION

UNPACKING

Thank you for purchasing the 7PZ IP by ADJ Products, LLC. Every 7PZ IP has been thoroughly tested and has been shipped in perfect operating condition. Carefully check the shipping carton for damage that may have occurred during shipping. If the carton appears to be damaged, carefully inspect your fixture for any damage and be sure all accessories necessary to operate the unit has arrived intact. In the case damage has been found or parts are missing, please contact our toll free customer support number for further instructions. Do not return this unit to your dealer without first contacting customer support.

INTRODUCTION

The 7PZ IP is an IP65 outdoor rated, DMX intelligent, zooming, LED par fixture with ADJ's WiFly TransCeiver with wireless DMX built-in. This fixture can be used in a stand alone mode or connected in a Primary/Secondary configuration. This wash has seven operating modes: 6Color Change mode, 30 Color Change mode, Auto Fade mode, Auto Run Mode, Manual Mode, Static Color Mode, and DMX Control Mode.

FEATURES

- Multi-Colors
- Electronic Dimming 0-100%
- 5-45 Degree Beam Angle
- DMX-512 protocol
- 3-Pin & 5-Pin DMX Connections
- 12 DMX Channel Modes
- Built-In ADJ's WiFly EXR Wireless DMX Up to 2,500 feet/760M•
- IP65 Locking 3/5-Pin XLR Connector In/Out
- IP65 Locking Power Connector In/Out
- Power Cord Daisy Chain

Included Accessories:

- 1 x IP65 Locking Power Cable
- 1 x Scissor Yoke

CUSTOMER SUPPORT

ADJ® provides a customer support line, to provide set up help and to answer any questions that may arise during your set up or initial operation. You may also visit us on the web at www.adj.com for any comments or suggestions. For service related issues please contact ADJ.

ADJ SERVICE USA - Monday - Friday 8:00am to 4:30pm PST

Voice: 800-322-6337 Fax: 323-532-2941 E-mail: support@adj.com

ADJ GROUP SERVICE EUROPE - Monday - Friday 08:30 to 17:00 CET

Voice: +31 45 546 85 30 Fax: +31 45 546 85 96 E-mail: support@americandj.eu

WARRANTY REGISTRATION

Please complete and mail in the enclosed warranty card to validate your purchase. All returned service items, whether under warranty or not, must be freight pre-paid and accompany a return authorization (R.A.) number. The R.A. number must be clearly written on the outside of the return package. A brief description of the problem as well as the R.A. number must also be written down on a piece of paper and included in the shipping container. If the unit is under warranty, you must provide a copy of your proof of purchase invoice. Items returned without an R.A. number clearly marked on the outside of the package will be refused and returned at customer's expense. You may obtain an R.A. number by contacting customer support.

IMPORTANT NOTICE!

THERE ARE NO USER SERVICEABLE PARTS INSIDE THIS DEVICE. DO NOT ATTEMPT ANY REPAIRS YOURSELF; DOING SO WILL VOID THE WARRANTY. DAMAGES RESULTING FROM MODIFICATIONS TO THIS DEVICE AND/OR THE DISREGARD OF SAFETY AND OPERATION INSTRUCTIONS IN THIS USER MANUAL VOIDS THE MANUFACTURER'S WARRANTY AND IS NOT SUBJECT TO ANY WARRANTY CLAIMS AND/OR REPAIRS.

SAFETY GUIDELINES

- **Do not** position device close to any **FLAMMABLE MATERIALS** while operating
- **Do not** expose this unit rain or moisture.
- **Do not** spill water or other liquids into or on to your unit.
- **Do not** attempt to operate this unit if the power cord has been frayed or broken.
- **Do not** attempt to remove or break off the ground prong from the electrical cord. This prong is used to reduce the risk of electrical shock and fire in case of an internal short.
- **Disconnect** from main power before making any type of connection.
- **Do not** remove the cover under any conditions. There are no user serviceable parts inside.
- **Never** operate this unit when it's cover is removed.
- **Never** plug this unit in to a dimmer pack.
- **Always** be sure to mount this unit in an area that will allow proper ventilation. Allow about 6" (15cm) between this device and a wall.
- **Do not** attempt to operate this unit, if it becomes damaged.
- **Do not** use of this product outdoors voids all warranties. his unit is intended for indoor use only.
- **Disconnect** mains power to the unit during long periods of non-use.
- **Always** mount this unit in safe and stable matter.
- **Always** route power-supply cords so that they are not likely to be walked on or pinched by items placed upon or against them, paying particular attention to the point they exit from the unit.
- **Cleaning** -The fixture should be cleaned only as recommended by the manufacturer.
- **Heat** - The appliance should be situated away from heat sources such as radiators, heat registers, stoves, or other appliances (including amplifiers) that produce heat.
- The fixture should be serviced by qualified service personnel when:
 - A. The power-supply cord or the plug has been damaged.
 - B. Objects have fallen, or liquid has been spilled into the appliance.
 - C. The appliance has been exposed to rain or water.
 - D. The appliance does not appear to operate normally or exhibits amarked change in performance.

ESD CAUTION: This unit, like any wireless electronic device is highly susceptible to ESD, electrostatic discharge. ESD can severely damage the unit.

IP NOTICE



An IP rated lighting fixture, which is commonly installed in outdoor environments, has been designed with an enclosure that effectively protects the ingress (entry) of external foreign objects such as dust and water. **The International Protection (IP)** rating system is commonly expressed as "IP" (Ingress Protection) followed by two numbers (i.e. IP65), where the numbers define the degree of protection. The first digit (Foreign Bodies Protection) indicates the extent of protection against particles entering the fixture, and the second digit (Water Protection) indicates the extent of protection against water entering the fixture. An IP65 rated lighting fixture is one, which has been designed and tested to protect against the ingress of dust (6) and low-pressure water jets from any direction (5).

M A R I N E / C O A S T A L E N V I R O N M E N T I N S T A L L A T I O N S !

Please note although this fixture is IP rated, the fixture is NOT suitable for marine and/or coastal environment installations. Installing this fixture in a marine and/or coastal environment may cause corrosion and/or excessive wear to the interior and/or exterior components of the fixture. Damages and/or performance issues resulting from installation in a marine and/or coastal environment will void the manufactures warranty and will NOT be subject to any warranty claims and/or repairs.

Ensure ALL connections and end caps are properly sealed with a non-conductive dielectric grease (available at most electrical suppliers) to prevent water ingress/condensation and/or corrosion.



OPTIONAL CORROSION - RESISTANT COATING Optional Corrosion-Resistant

Coatings may be available for this fixture. Please consult your **ADJ Products, LLC** sales representative for details.

PROTECTIVE VENT

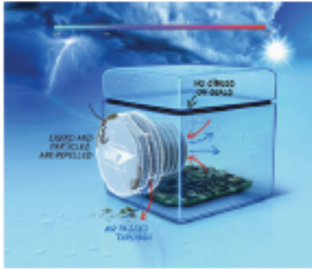

This IP rated fixture features a protective vent valve that equalizes the pressure, prevents contamination, and reduces condensation, ultimately extending the lifetime of the fixture.



I M P O R T A N T M U S T R E A D

If this fixture is installed in an extreme and/or harsh outdoor/wet environment, it **MUST** be powered ON and used for a minimum of 30 minutes every 10-15 days. Prolonged exposure to an extreme and/or harsh outdoor/wet environment without usage as stated above can lead to component damage and/or shortening the lifetime of the fixture. Any component damage found to be as a direct result of not following this guideline may void the limited warranty.

SET UP

Power Supply: The ADJ 7PZ IP contains an automatic voltage switch, which will auto sense the voltage when it is plugged into the power source. With this switch there is no need to worry about the correct power voltage, this unit can be plugged in anywhere.

DMX-512: DMX is short for Digital Multiplex. This is a universal protocol used as a form of communication between intelligent fixtures and controllers. A DMX controller sends DMX data instructions from the controller to the fixture. DMX data is sent as serial data that travels from fixture to fixture via the DATA “IN” and DATA “OUT” XLR terminals located on all DMX fixtures (most controllers only have a DATA “OUT” terminal).

DMX Linking: DMX is a language allowing all makes and models of different manufactures to be linked together and operate from a single controller, as long as all fixtures and the controller are DMX compliant. To ensure proper DMX data transmission, when using several DMX fixtures try to use the shortest cable path possible. The order in which fixtures are connected in a DMX line does not influence the DMX addressing. For example; a fixture assigned a DMX address of 1 may be placed anywhere in a DMX line, at the beginning, at the end, or anywhere in the middle. When a fixture is assigned a DMX address of 1, the DMX controller knows to send DATA assigned to address 1 to that unit, no matter where it is located in the DMX chain.

Data Cable (DMX Cable Requirements (For DMX Operation: The 7PZ IP can be controlled via DMX-512 protocol. Your unit and your DMX controller requires either a 3-pin or 5-pin XLR connector for data input and data output. We recommend Accu-Cable DMX cables. If you are making your own cables, be sure to use standard 110-120 Ohm shielded cable (This cable may be purchased at almost all pro lighting stores). Your cables should be made with a male and female XLR connector on either end of the cable. Also remember that DMX cable must be daisy chained and cannot be split.

TO MAINTAIN IP65 RATING INTEGRITY AND PREVENT WATER FROM ENTERING THE FIXTURE, ALL UNUSED CONNECTION RUBBER CAPS MUST BE SEALED AND ONLY IP65 RATED POWER AND DATE CABLES MUST BE USED.

SET UP

Special Note: Line Termination. When longer runs of cable are used, you may need to use a terminator on the last unit to avoid erratic behavior. A terminator is a 110-120 ohm 1/4 watt resistor which is connected between pins 2 and 3 of a male XLR connector (DATA + and DATA -). This unit is inserted in the female XLR connector of the last unit in your daisy chain to terminate the line. Using a cable terminator (ADJ part number Z-DMX/T) will decrease the possibilities of erratic behavior.



Termination reduces signal errors and avoids signal transmission problems and interference. It is always advisable to connect a DMX terminal, (Resistance 120 Ohm 1/4 W) between PIN 2 (DMX-) and PIN 3 (DMX +) of the last fixture.

5-Pin XLR DMX Connectors. Some manufactures use 5-pin DMX- 512 data cables for DATA transmission in place of 3-pin. 5-pin DMX fixtures may be implemented in a 3-pin DMX line. When inserting standard 5-pin data cables in to a 3-pin line a cable adaptor must be used, these adaptors are readily available at most electric stores. The chart below details a proper cable conversion.

3-Pin XLR to 5-Pin XLR Conversion		
Conductor Ground/ Shield	3-Pin XLR Female (Out)	5-Pin XLR Male (In)
Ground/Shield	Pin 1	Pin 1
Data Compliment (- signal)	Pin 2	Pin 2
Data True (+ signal)	Pin 3	Pin 3
Not Used		Do Not Use
Not Used		Do Not Use

4 CHANNEL - HSI

Channel	Value	Function
1	0 - 255	HUE: 0 - 100%
2	0 - 255	SATURATION: 0 - 100%
3	0 - 255	INTENSITY: 0 - 100%
4	0 - 255	ZOOM: NARROW - WIDE

5 CHANNEL - RGBW

Channel	Value	Function
1	0 - 255	RED: 0 - 100%
2	0 - 255	GREEN: 0 - 100%
3	0 - 255	BLUE: 0 - 100%
4	0 - 255	WHITE: 0 - 100%
5	0 - 255	ZOOM: NARROW - WIDE

5 CHANNEL - HSI + ZOOM

Channel	Value	Function
1	0 - 255	HUE: 0 - 100%
2	0 - 255	SATURATION: 0 - 100%
3	0 - 255	INTENSITY: 0 - 100%
4	0 - 255	ZOOM: NARROW - WIDE
5	0 - 20 21 - 40 41 - 60 61 - 80 81 - 100 101-255	DIMMER CURVES: STANDARD STAGE TV ARCHITECTURAL THEATRE DEFAULT TO UNIT CURVE SETTING

6 CHANNEL - RGBW + ZOOM

Channel	Value	Function
1	0 - 255	RED: 0 - 100%
2	0 - 255	GREEN: 0 - 100%
3	0 - 255	BLUE: 0 - 100%
4	0 - 255	WHITE: 0 - 100%
5	0 - 255	MASTER DIMMER: 0 - 100%
6	0 - 255	ZOOM: NARROW - WIDE

7 CHANNEL - sRGBWI

Channel	Value	Function
1	0 - 31	SHUTTER/STROBE LED OFF
	32 - 63	LED ON
	64 - 95	STROBING SLOW - FAST
	96 - 127	LED ON
	128 - 159	STROBE PULSE SLOW - FAST
	160 - 191	LED ON
	192 - 223	RANDOM STROBE SLOW - FAST
	224 - 255	LED ON
2	0 - 255	RED: 0 - 100%
3	0 - 255	GREEN: 0 - 100%
4	0 - 255	BLUE: 0 - 100%
5	0 - 255	WHITE: 0 - 100%
6	0 - 255	INTENSITY: 0 - 100%
7	0 - 255	ZOOM: NARROW - WIDE

7 CHANNEL - RGBW

Channel	Value	Function
1	0 - 255	RED: 0 - 100%
2	0 - 255	GREEN: 0 - 100%
3	0 - 255	BLUE: 0 - 100%
4	0 - 255	WHITE: 0 - 100%
5	0 - 255	MASTER DIMMER: 0 - 100%
6	0 - 255	MASTER DIMMER (FINE): 0 - 100%
7	0 - 255	ZOOM: NARROW - WIDE

8 CHANNEL - RGBW

Channel	Value	Function
1	0 - 255	RED: 0 - 100%
2	0 - 255	GREEN: 0 - 100%
3	0 - 255	BLUE: 0 - 100%
4	0 - 255	WHITE: 0 - 100%
5	0 - 31	SHUTTER/STROBE LED OFF
	32 - 63	LED ON
	64 - 95	STROBING SLOW - FAST
	96 - 127	LED ON
	128 - 159	STROBE PULSE SLOW - FAST
	160 - 191	LED ON
	192 - 223	RANDOM STROBE SLOW - FAST
	224 - 255	LED ON
6	0 - 255	MASTER DIMMER: 0 - 100%
7	0 - 255	MASTER DIMMER (FINE): 0 - 100%
8	0 - 255	ZOOM: NARROW - WIDE

9 CHANNEL - RGBW

Channel	Value	Function
1	0 - 255	RED: 0 - 100%
2	0 - 255	GREEN: 0 - 100%
3	0 - 255	BLUE: 0 - 100%
4	0 - 255	WHITE: 0 - 100%
5	0 - 31 32 - 63 64 - 95 96 - 127 128 - 159 160 - 191 192 - 223 224 - 255	SHUTTER/STROBE LED OFF LED ON STROBING SLOW - FAST LED ON STROBE PULSE SLOW - FAST LED ON RANDOM STROBE SLOW - FAST LED ON
6	0 - 255	MASTER DIMMER: 0 - 100%
7	0 - 255	MASTER DIMMER (FINE): 0 - 100%
8	0 - 255	ZOOM: NARROW - WIDE
9	0 - 20 21 - 40 41 - 60 61 - 80 81 - 100 101-255	DIMMER CURVES: STANDARD STAGE TV ARCHITECTURAL THEATRE DEFAULT TO UNIT CURVE SETTING

10 CHANNEL - RGBW 16-BIT

Channel	Value	Function
1	0 - 255	RED: 0 - 100%
2	0 - 255	RED (FINE): 0 - 100%
3	0 - 255	GREEN: 0 - 100%
4	0 - 255	GREEN (FINE): 0 - 100%
5	0 - 255	BLUE: 0 - 100%
6	0 - 255	BLUE (FINE): 0 - 100%
7	0 - 255	WHITE: 0 - 100%
8	0 - 255	WHITE (FINE): 0 - 100%
9	0 - 255	ZOOM: NARROW - WIDE
10	0 - 255	ZOOM (FINE): NARROW - WIDE

10 CHANNEL - HSI

Channel	Value	Function
1	0 - 31 32 - 63 64 - 95 96 - 127 128 - 159 160 - 191 192 - 223 224 - 255	SHUTTER/STROBE LED OFF LED ON STROBING SLOW - FAST LED ON STROBE PULSE SLOW - FAST LED ON RANDOM STROBE SLOW - FAST LED ON
2	0 - 255	HUE: 0 - 100%
3	0 - 255	SATURATION: 0 - 100%
4	0 - 255	INTENSITY: 0 - 100%
5	0 - 255	COLOR MACROS (See page 22, Color Macro Chart)
6	0 - 255	ZOOM: NARROW - WIDE
7	1 - 20 21 - 40 41 - 60 61 - 80 81 - 100 101 - 120 121 - 140 141 - 160 161 - 180 181 - 200 201 - 220 221 - 240 241 - 250 251 - 255	AUTO PROGRAMS PROGRAM 1 PROGRAM 2 PROGRAM 3 PROGRAM 4 PROGRAM 5 PROGRAM 6 PROGRAM 7 PROGRAM 8 PROGRAM 9 PROGRAM 10 PROGRAM 11 PROGRAM 12 PROGRAM 13 GRADIENT EFFECT
8		AUTO PROGRAMS SPEED: SLOW - FAST
9		AUTO PROGRAMS FADE: SLOW - FAST
10	0 - 20 21 - 40 41 - 60 61 - 80 81 - 100 101-255	DIMMER CURVES: STANDARD STAGE TV ARCHITECTURAL THEATRE DEFAULT TO UNIT CURVE SETTING

12 CHANNEL - RGBWI

Channel	Value	Function
1	0 - 31 32 - 63 64 - 95 96 - 127 128 - 159 160 - 191 192 - 223 224 - 255	SHUTTER/STROBE LED OFF LED ON STROBING SLOW - FAST LED ON STROBE PULSE SLOW - FAST LED ON RANDOM STROBE SLOW - FAST LED ON
2	0 - 255	RED: 0 - 100%
3	0 - 255	GREEN: 0 - 100%
4	0 - 255	BLUE: 0 - 100%
5	0 - 255	WHITE: 0 - 100%
6	0 - 255	INTENSITY: 0 - 100%
7	0 - 255	COLOR MACROS (See page 22, Color Macro Chart)
8	0 - 255	ZOOM: NARROW - WIDE
9	1 - 20 21 - 40 41 - 60 61 - 80 81 - 100 101 - 120 121 - 140 141 - 160 161 - 180 181 - 200 201 - 220 221 - 240 241 - 250 251 - 255	AUTO PROGRAMS PROGRAM 1 PROGRAM 2 PROGRAM 3 PROGRAM 4 PROGRAM 5 PROGRAM 6 PROGRAM 7 PROGRAM 8 PROGRAM 9 PROGRAM 10 PROGRAM 11 PROGRAM 12 PROGRAM 13 GRADIENT EFFECT
10	0 - 255	AUTO PROGRAMS SPEED: SLOW - FAST
11	0 - 255	AUTO PROGRAMS FADE: SLOW - FAST
12	0 - 20 21 - 40 41 - 60 61 - 80 81 - 100 101-255	DIMMER CURVES: STANDARD STAGE TV ARCHITECTURAL THEATRE DEFAULT TO UNIT CURVE SETTING

13 CHANNEL - RGBW

Channel	Value	Function
1	0 - 255	RED: 0 - 100%
2	0 - 255	GREEN: 0 - 100%
3	0 - 255	BLUE: 0 - 100%
4	0 - 255	WHITE: 0 - 100%
5	0 - 255	COLOR MACROS (See page 22, Color Macro Chart)
6	0 - 31 32 - 63 64 - 95 96 - 127 128 - 159 160 - 191 192 - 223 224 - 255	SHUTTER/STROBE LED OFF LED ON STROBING SLOW - FAST LED ON STROBE PULSE SLOW - FAST LED ON RANDOM STROBE SLOW - FAST LED ON
7	0 - 255	MASTER DIMMER: 0 - 100%
8	0 - 255	MASTER DIMMER (FINE): 0 - 100%
9	0 - 255	ZOOM: NARROW - WIDE
10	1 - 20 21 - 40 41 - 60 61 - 80 81 - 100 101 - 120 121 - 140 141 - 160 161 - 180 181 - 200 201 - 220 221 - 240 241 - 250 251 - 255	AUTO PROGRAMS PROGRAM 1 PROGRAM 2 PROGRAM 3 PROGRAM 4 PROGRAM 5 PROGRAM 6 PROGRAM 7 PROGRAM 8 PROGRAM 9 PROGRAM 10 PROGRAM 11 PROGRAM 12 PROGRAM 13 GRADIENT EFFECT
11	0 - 255	AUTO PROGRAMS SPEED: SLOW - FAST
12	0 - 255	AUTO PROGRAMS FADE: SLOW - FAST
13	0 - 20 21 - 40 41 - 60 61 - 80 81 - 100 101-255	DIMMER CURVES: STANDARD STAGE TV ARCHITECTURAL THEATRE DEFAULT TO UNIT CURVE SETTING

OPERATING INSTRUCTIONS

LED Display On/Off:

To set the LED display to turn off after 60 seconds, press the MODE button until **“don”** is displayed, press the UP button to display **“doff”**. Now the display will disappear after 60s. Press any button to turn the display on again. Be advised though that the display will turn off automatically after 10 seconds.

To set the display press the MODE button until **“dXX”** is displayed. Use the UP or DOWN buttons to select either: **“don”** = LED display on at all times.

“doff” = LED display shuts off after 60 seconds.

LED Display Inversion:

Follow these instructions to flip the display 180° so that the display can be read upside down.

1. Plug the fixture in and press the MODE button until **“dXX”** is displayed. **“XX”** represents either **“on”** or **“off”**.
2. Press the SET UP button until **“Stnd”** or **“rev”** is displayed. 3. Press the UP or DOWN buttons to reverse the display 180°.

DMX Mode:

Operating through a DMX controller gives the user the freedom to create their own programs tailored to their needs. This function also allows the fixtures to be used as spotlights. The 7PZ IP has 12 DMX modes.

1. This function will allow you to control each individual fixture's traits with a standard DMX 512 controller.
2. To run your fixture in DMX mode, enter the MENU screen by pressing and holding the MODE button. Press the UP or DOWN buttons until **“Menu Set ADDR”** is displayed. Press the ENTER button then use the UP or DOWN buttons to select your desired DMX address. Press ENTER after you have found your desired address.
3. After you have set your desired DMX address, select your desired DMX channel mode. Access the main menu and press the UP or DOWN buttons until **“Menu UserMode”** is displayed.
4. Use the UP or DOWN buttons to scroll through the DMX Channel modes. When you have found your desired DMX Channel mode press ENTER.
5. Please see pages 9-21 for DMX values and traits.
6. After you have chosen your desired DMX Channel mode plug in the fixture via the XLR connections to any standard DMX controller.

Dimmer Curve Setting:

1. Plug the fixture in and access the main menu. Press the UP or DOWN buttons until **“Menu Function”** is displayed, and press ENTER.
2. Press the UP or DOWN buttons until **“Dim Curve”** is displayed, and press ENTER.
3. Press the UP or DOWN buttons to find your desired dimmer curve. Press ENTER to select and confirm. Please see the Dimmer Curve Diagram Chart on page 31 to see the settings and their respective beginning and ending fade times.

Color Balance Mode:

1. Plug the fixture in and access the main menu. Press the UP or DOWN buttons until **“Menu Function”** is displayed, and press ENTER.
2. Press the UP or DOWN buttons until **“Settings WhiteBal”** is displayed, and press ENTER. Use the UP or DOWN buttons to scroll through the RGBW colors. When you find a color you would like to adjust press ENTER. Use the UP or DOWN buttons to adjust the color output and press ENTER when done.
3. When you are finished making your adjustments press the MODE button to exit this menu.

OD9 F 5 H=B; `=BGHF I 7 H=C BG

No DMX Hold:

This mode is used as a precaution mode, that in case the DMX signal is lost, the operating mode chosen in this setup is the running mode the fixture will go into when the DMX signal is lost. You can also set this as the operating mode you would like the unit to return to when power is applied.

1. Plug the fixture in and access the main menu. Press the UP or DOWN buttons until “**Menu Function**” is displayed, and press ENTER.
2. Press the UP or DOWN buttons until “**No DMX Hold**” is displayed, and press ENTER. Use the UP or DOWN buttons to find your desired setting.
 - “**Blackout**” - If the DMX signal is lost or interrupted, the unit will automatically go into stand by mode.
 - “**Hold**” (Last State) - If the DMX signal is lost or interrupted, the fixture will stay in the last DMX set up. If power is applied and this mode is set, the unit will automatically go into the last DMX set up.
 - “**Program**” - If the DMX signal is lost or interrupted, the unit will automatically run a built-in program.
3. Find your desired setting and press ENTER. Your setting will be saved automatically.

Zoom:

The zoom function indicated here works with Auto Run mode, Static color mode, 6 Color change mode, 30 Color change mode, and Auto Fade mode.

1. Plug the fixture in and access the main menu. Press the UP or DOWN buttons until “**Menu Function**” is displayed, and press ENTER.
2. Press the UP or DOWN buttons until “**Zoom**” is displayed, and press ENTER.
3. Use the UP or DOWN buttons to adjust the zoom.
4. When you are finished making your adjustment press ENTER and press the MODE button to exit this menu.

Auto Run Mode:

1. Plug the fixture in and access the main menu. Press the UP or DOWN buttons until “**Menu Function**” is displayed, and press ENTER.
2. Press the UP or DOWN buttons until “**Auto Run FQN**” is displayed, and press ENTER.
3. Use the UP or DOWN buttons to adjust the Auto Run.
4. When you are finished making your adjustment press ENTER and press the MODE button to exit this menu.

Static Color Mode:

1. Plug the fixture in and access the main menu. Press the UP or DOWN buttons until “**Menu Function**” is displayed, and press ENTER.
2. Press the UP or DOWN buttons until “**Static CL:X**” is displayed, and press ENTER.
3. Press ENTER again to adjust the static colors. Use the UP or DOWN buttons to scroll through the colors.
4. When you have found your desired color press ENTER. You are now in the strobe menu. You can use the UP or DOWN buttons to adjust the strobe rate. Press ENTER when have finished making your adjustments.

6 Color Change Mode:

1. Plug the fixture in and access the main menu. Press the UP or DOWN buttons until “**Menu Function**” is displayed, and press ENTER.
2. Press the UP or DOWN buttons until “**Static CL:X**” is displayed, and press ENTER.
3. Use the UP or DOWN buttons to scroll until “**2. Chang6**” is displayed. Press ENTER and use the UP or DOWN buttons to adjust the color change speed.
4. When you have found your desired color change speed press ENTER. You are now in the strobe menu. You can use the UP or DOWN buttons to adjust the strobe rate. Press ENTER when have finished making your adjustments.

OPERATING INSTRUCTIONS

30 Color Change Mode:

1. Plug the fixture in and access the main menu. Press the UP or DOWN buttons until “**Menu Function**” is displayed, and press ENTER.
2. Press the UP or DOWN buttons until “**Static CL:X**” is displayed, and press ENTER.
3. Use the UP or DOWN buttons to scroll until “**Chang30**” is displayed. Press ENTER and use the UP or DOWN buttons to adjust the color change speed.
4. When you have found your desired color change speed press ENTER. You are now in the strobe menu. You can use the UP or DOWN buttons to adjust the strobe rate. Press ENTER when you have finished making your adjustments.

Auto Fade Mode:

1. Plug the fixture in and access the main menu. Press the UP or DOWN buttons until “**Menu Function**” is displayed, and press ENTER.
2. Press the UP or DOWN buttons until “**Static CL:X**” is displayed, and press ENTER.
3. Use the UP or DOWN buttons to scroll until “**4. Fade**” is displayed. Press ENTER and use the UP or DOWN buttons to adjust the color change speed.
4. When you have found your desired color fade speed press ENTER. You are now in the strobe menu. You can use the UP or DOWN buttons to adjust the strobe rate. Press ENTER when you have finished making your adjustments.

Color Macros Mode:

1. Plug the fixture in and access the main menu. Press the UP or DOWN buttons until “**Menu Function**” is displayed, and press ENTER.
2. Press the UP or DOWN buttons until “**Macros**” is displayed, and press ENTER.
3. Use the UP or DOWN buttons to scroll through the 63 color macros.
4. When you have found your desired color you are now in the Zoom menu. You can use the UP or DOWN buttons to manually adjust the zoom. Press ENTER when you have finished making your adjustments.

Wireless Address:

This function is used to set the wireless address. This address must match the address that is set to WiFly Transceiver or WiFly controller.

1. Plug the fixture in and access the main menu. Press the UP or DOWN buttons until “**Menu Function**” is displayed, and press ENTER.
2. Press the UP or DOWN buttons until “**Wireless CH:XX**” is displayed. “**XX**” represents the current displayed address. Press ENTER to access, and use the UP or DOWN buttons to adjust the wireless channel.
3. When you are finished making your adjustment press ENTER and press the MODE button to exit this menu.

LCD.Set:

This menu is used to adjust the backlight to stay on all the time or turn off after about 5 seconds, set the Key Lock, and Display Flash.

1. Plug the fixture in and access the main menu. Press the UP or DOWN buttons until “**Menu Function**” is displayed, and press ENTER.
2. Press the UP or DOWN buttons until “**LCD.Set**” is displayed. Press ENTER to the menu. Use the UP or DOWN buttons to make adjustments. Press the ENTER button to scroll between the 3 menus.
3. When you are finished making your adjustment press ENTER and press the MODE button to exit this menu.

OPERATING INSTRUCTIONS

Default Settings:

When this mode is activated the unit will return to their default settings.

1. Plug the fixture in and access the main menu. Press the UP or DOWN buttons until “**Menu Function**” is displayed, and press ENTER.
2. Press the UP or DOWN buttons until “**DFSET**” is displayed, and press ENTER.
3. Use UP or DOWN buttons to switch between “**ON/OFF.**” If you would like the default setting highlight “**ON**” and press ENTER. Press the MODE button to exit.

Temperature C/F:

With this function, you can change the temperature display to show either Celsius or Fahrenheit.

1. Press the MODE button to access the main menu. Press the UP or DOWN buttons so that “**Menu Function**” is highlighted, then press ENTER.
2. Press UP or DOWN buttons, until “**Temp**” is displayed, and press ENTER.
3. Either “**Celsius**” or “**Fahrenheit**” will be displayed, use the UP and DOWN buttons to switch between.
4. Press ENTER to confirm your selection or press MODE to exit.

WiFLY On/Off:

This function is used to turn the WiFly function on and off.

1. Plug the fixture in and access the main menu. Press the UP or DOWN buttons until “**Menu Function**” is displayed, and press ENTER.
2. Press the UP or DOWN buttons until “**Wireless**” is displayed. Press ENTER to access, and use the UP or DOWN buttons to switch between “**ON**” (wireless activated) or “**OFF**” (wireless deactivated).
3. Press ENTER to confirm your selection and press the MODE button to exit this menu.

Current Running Time:

1. Press the MODE button to access the main menu. Press the UP or DOWN buttons so that “**Menu Info**” is highlighted, then press ENTER.
2. Press the UP or DOWN buttons, until “**Info TimeInfo**” is displayed, and press ENTER.
3. Press the UP or DOWN buttons, until “**TimeInfo Current**” is displayed, and press ENTER.
4. The current running time will now be displayed, press MODE to exit.

Total Running Time:

1. Press the MODE button to access the main menu. Press the UP or DOWN buttons so that “**Menu Info**” is highlighted, then press ENTER.
2. Press the UP or DOWN buttons, until “**Info TimeInfo**” is displayed, and press ENTER.
3. Press the UP or DOWN buttons, until “**TimeInfo TotalTim**” is displayed, and press ENTER.
4. The total running time will now be displayed, press MODE to exit.

Last time the current running time was cleared:

1. Press the MODE button to access the main menu. Press the UP or DOWN buttons so that “**Menu Info**” is highlighted, then press ENTER.
2. Press the UP or DOWN buttons, until “**Info TimeInfo**” is displayed, and press ENTER.
3. Press the UP or DOWN buttons, until “**TimeInfo LastClea**” is displayed, and press ENTER.
4. The the last time the current running time was cleared will now be displayed, press MODE to exit.

OPERATING INSTRUCTIONS

TimerPin (Clear current Running Time):

In this menu you must input the timer pin to clear the current running time.

1. Press the MODE button to access the main menu. Press the UP or DOWN buttons so that “Menu Info” is highlighted, then press ENTER.
2. Press the UP or DOWN buttons, until “Info TimeInfo” is displayed, and press ENTER.
3. Press the UP or DOWN buttons, until “TimeInfo TimerPIN” is displayed, and press ENTER.
4. You must now put in the Pin number “050” to clear the current running time.

Current Running Temperature:

1. Press the MODE button to access the main menu. Press the UP or DOWN buttons so that “Menu Info” is highlighted, then press ENTER.
2. Press the UP or DOWN buttons, until “Info TempInfo” is displayed, and press ENTER.
3. The current running temperature will now be displayed. Press the MODE button to exit.

Model Info:

1. Press the MODE button to access the main menu. Press the UP or DOWN buttons so that “Menu Info” is highlighted, then press ENTER.
2. Press the UP or DOWN buttons, until “Info Model Inf” is displayed, and press ENTER.
3. The name of the unit will now be displayed, press MODE to exit.

Software Info:

1. Press the MODE button to access the main menu. Press the UP or DOWN buttons so that “Menu Info” is highlighted, then press ENTER.
2. Press the UP or DOWN buttons, until “Info Software” is displayed, and press ENTER.
3. The software version will now be displayed, press MODE to exit.

Error Info:

1. Press the MODE button to access the main menu. Press the UP or DOWN buttons so that “Menu Info” is highlighted, then press ENTER.
2. Press the UP or DOWN buttons, until “Info ErrorInf” is displayed, and press ENTER.
3. Any errors that may have occurred will be displayed, press MODE to exit.

Zoom Reset:

1. Press the MODE button to access the main menu. Press the UP or DOWN buttons so that “Menu ZoomRset” is highlighted, then press ENTER.
2. Press the UP or DOWN buttons, until “ZoomRset Reset. M” is displayed, and press ENTER.
3. The display will now show “Reset. M Zoom”. Press ENTER to reset the zoom function.

Zoom Calibration: With this function you can calibrate and adjust the zoom function to its correct position. The Calibration password 050.

NOTE: ONLY QUALIFIED TECHNICIANS SHOULD PERFORM THIS FUNCTION.

1. Press the MODE button to access the main menu. Press the UP or DOWN buttons so that “Menu ZoomRset” is highlighted, then press ENTER.
2. Press the UP or DOWN buttons, until “ZoomRset Calibrat” is displayed, and press ENTER.
3. The display will now show the current calibration setting.

OPERATING INSTRUCTIONS

Secondary Setting:

1. Press the MODE button to access the main menu. Press the UP or DOWN buttons so that “**Menu Secondary**” is highlighted, then press ENTER.
2. The display will now show “**Secondary**” designating it as the secondary fixture in a Primary-Secondary set up.
3. The display will now show “**Reset. M Zoom**”. Press ENTER to reset the zoom function.

Manual Control:

1. Press the MODE button to access the main menu. Press the UP or DOWN buttons so that “**Menu Manual**” is highlighted, then press ENTER.
2. Use the UP and DOWN buttons to scroll through the manual settings that include Zoom, Master Dimmer, Red Intensity, Green Intensity, Blue Intensity, White Intensity, and Strobe.
3. When you find a setting you would like to adjust press ENTER. Use the UP and DOWN buttons to make adjustments, then press ENTER.

PRIMARY-SECONDARY CONFIGURATION

This function will allow you to link units together to run in a Primary-Secondary mode. In Primary-Secondary operation one unit will act as the controlling unit and the others will react to the controlling units built-in programs. Any unit can act as a Primary or as a Secondary; however, only one unit can be programmed to act as the “**Primary.**”

Primary-Secondary Connections and Settings:

1. Daisy chain your units via the XLR connector on the rear of the unit. Use standard XLR data cables to link your units together. Remember that the Male XLR connector is the input and the Female XLR connector is the output. The first unit in the chain (primary) will use the female XLR connector only. The last unit in the chain will use the male XLR connector only.
2. Connect the first “**Secondary**” unit to the “**Primary**”, and the “**Secondary**” unit should now start to follow the “**Primary**”.
3. Set the “**Primary**” unit to your desired mode of operation.
4. On the “**Secondary**” units press the MODE button until “**Menu Secondary**” is displayed and press ENTER. The unit is now set as the “**Secondary**” unit. Each secondary unit must be set to the same setting.

WIFLY SETUP

With this feature you are able to control the unit with DMX without the need of XLR cables. Your DMX controller must be connected to a ADJ WiFly TransCeiver to use this function. You are able to communicate up to 2500 feet/760 meters (open line of sight).

1. Turn on the WiFly function using the instructions on page 17.
2. Follow the instructions on page 26 to set the Wireless address. The address must match the address set on the WiFly Transceiver.
3. After you have set the WiFly address, follow the DMX instructions on pages 15-16 to select your desired DMX Channel mode and set your DMX address.
4. Apply power to the ADJ WiFly Transceiver. The fixture must be set up first before you apply power to WiFly Transceiver.

Note: If the sync does not work, switch the WiFly power off then on again.

WIFLY PRIMARY-SECONDARY SETUP

This feature will let you link units to run in a Primary-Secondary mode without the use of XLR cables.

1. Follow the instructions on page 26 to set the Wireless address. The addresses on each fixture must be the same.
2. After you have set the WiFly address, select your primary unit and set your desired operating mode.
3. Turn on the WiFly function using the instructions on page 18.
4. For the Secondary units, put the unit in **Secondary** mode. See Primary-Secondary configuration when setting the unit as a Secondary, then switch ON the WiFly power.

NOTE: If they do not sync up Primary-secondary, switch the Primary fixtures WiFly off then on again.

COLOR MACRO CHART

Color No.	DMX Value	RGBA COLOR INTENSITY				Color No.	DMX Value	RGBA COLOR INTENSITY			
		RED	GREEN	BLUE	AMBER			RED	GREEN	BLUE	AMBER
OFF	0	0	0	0	0	Color33	129-132	255	206	143	0
Color1	1-4	80	255	234	80	Color34	133-136	254	177	153	0
Color2	5-8	80	255	164	80	Color35	137-140	254	192	138	0
Color3	9-12	77	255	112	77	Color36	141-144	254	165	98	0
Color4	13-16	117	255	83	83	Color37	145-148	254	121	0	0
Color5	17-20	160	255	77	77	Color38	149-152	176	17	0	00
Color6	21-24	223	255	83	83	Color39	153-156	96	0	11	0
Color7	25-28	255	243	77	77	Color40	157-160	234	139	171	0
Color8	29-32	255	200	74	74	Color41	161-164	224	5	97	0
Color9	33-36	255	166	77	77	Color42	165-168	175	77	173	0
Color10	37-40	255	125	74	74	Color43	169-172	119	130	199	0
Color11	41-44	255	97	77	74	Color44	173-176	147	164	212	0
Color12	45-48	255	71	77	71	Color45	177-180	88	2	163	0
Color13	49-52	255	83	134	83	Color46	181-184	0	38	86	0
Color14	53-56	255	93	182	93	Color47	185-188	0	142	208	0
Color15	57-60	255	96	236	96	Color48	189-192	52	148	209	0
Color16	61-64	238	93	255	93	Color49	193-196	1	134	201	0
Color17	65-68	196	87	255	87	Color50	197-200	0	145	212	0
Color18	69-72	150	90	255	90	Color51	201-204	0	121	192	0
Color19	73-76	100	77	255	77	Color52	205-208	0	129	184	0
Color20	77-80	77	100	255	77	Color53	209-212	0	83	115	0
Color21	81-84	67	148	255	67	Color54	213-216	0	97	166	0
Color22	85-88	77	195	255	77	Color55	217-220	1	100	167	0
Color23	89-92	77	234	255	77	Color56	221-224	0	40	86	0
Color24	93-96	158	255	144	144	Color57	225-228	209	219	182	0
Color25	97-100	255	251	153	153	Color58	229-232	42	165	85	0
Color26	101-104	255	175	147	147	Color59	233-236	0	46	35	0
Color27	105-108	255	138	186	138	Color60	237-240	8	107	222	0
Color28	109-112	255	147	251	147	Color61	241-244	107	156	231	0
Color29	113-116	151	138	255	138	Color62	245-248	165	198	247	0
Color30	117-120	151	138	255	138	Color63	249-252	0	0	189	0
Color31	121-124	138	169	255	138	Color64	253-255	255	255	255	0
Color32	125-128	255	255	255	255	Color65					

DIMMER CURVE CHART

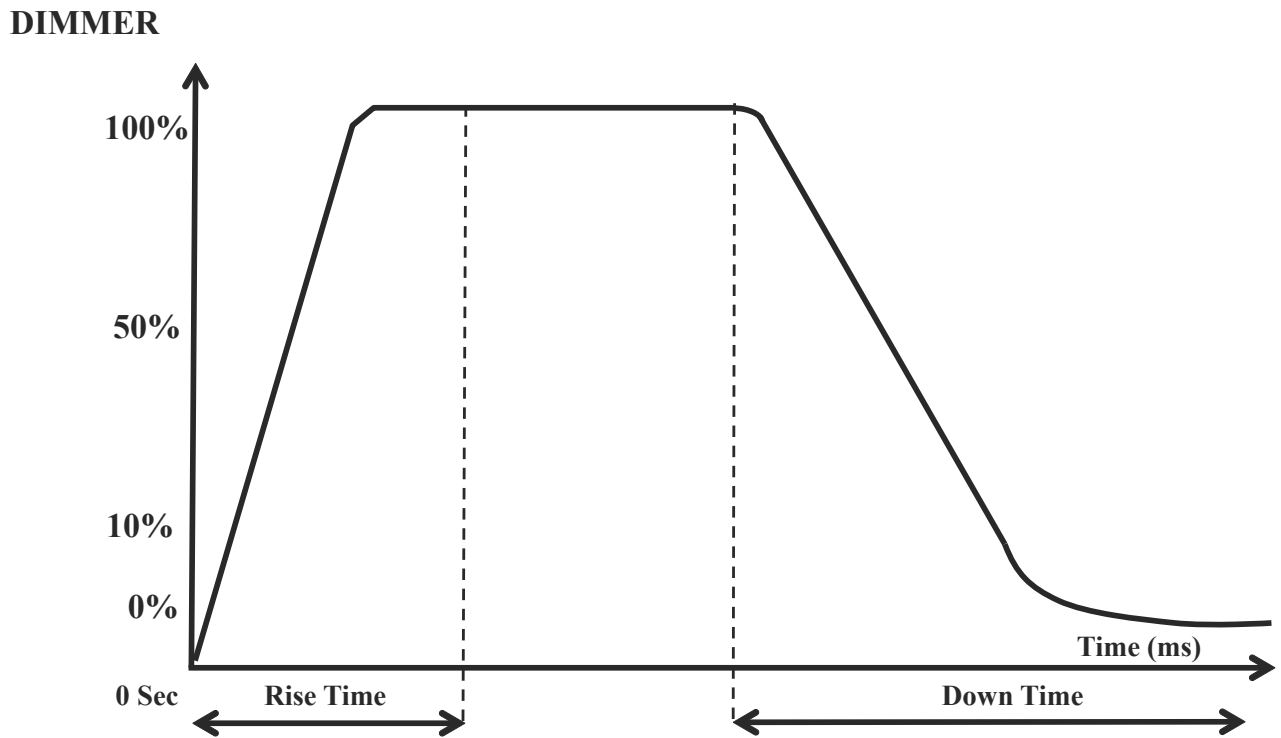

Dimming Curve Ramp Effect	0 sec Fade Time		1 sec Fade Time	
	Rise Time (ms)	Down Time (ms)	Rise Time (ms)	Down Time (ms)
Standard (default)	0	0	0	0
Stage	780	1100	1540	1660
TV	1180	1520	1860	1940
Architectural	1380	1730	2040	2120
Theatre	1580	1940	2230	2280

DIMENSIONS

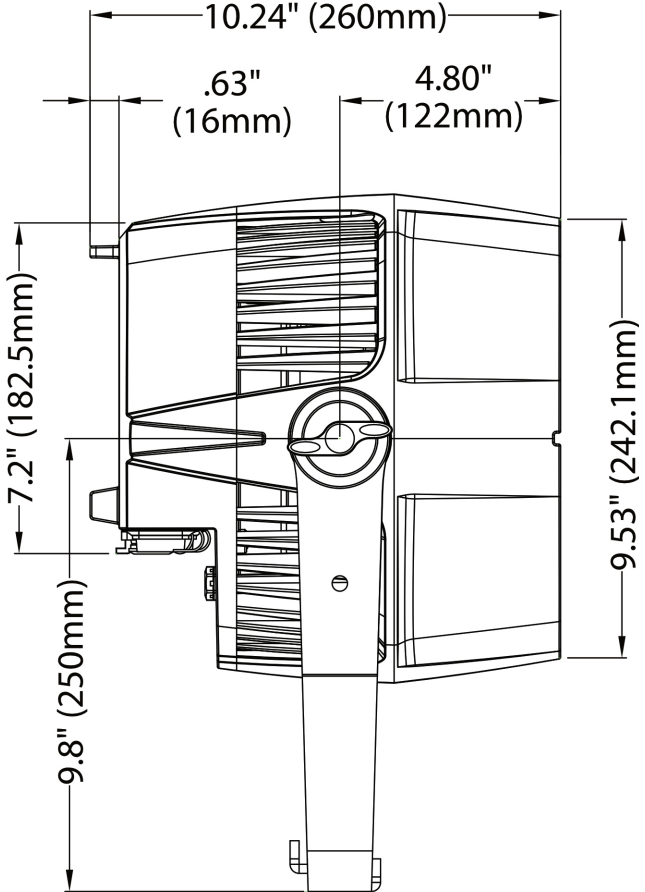
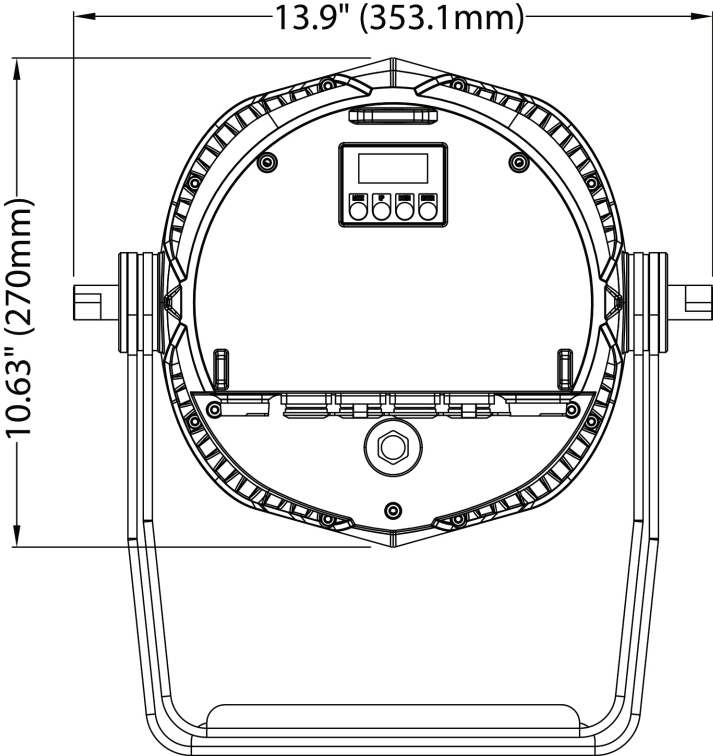

PHOTOMETRIC CHART

Beam angle 5°

Field angle 10°

Intensity(LUX)

Red LEDs	7178	2861	1448	853	547
Green LEDs	19420	7592	3804	2230	1459
Blue LEDs	3583	1380	652	433	290
White LEDs	20070	7737	4041	2366	1586
Full LEDs	40800	16050	8180	4851	3169

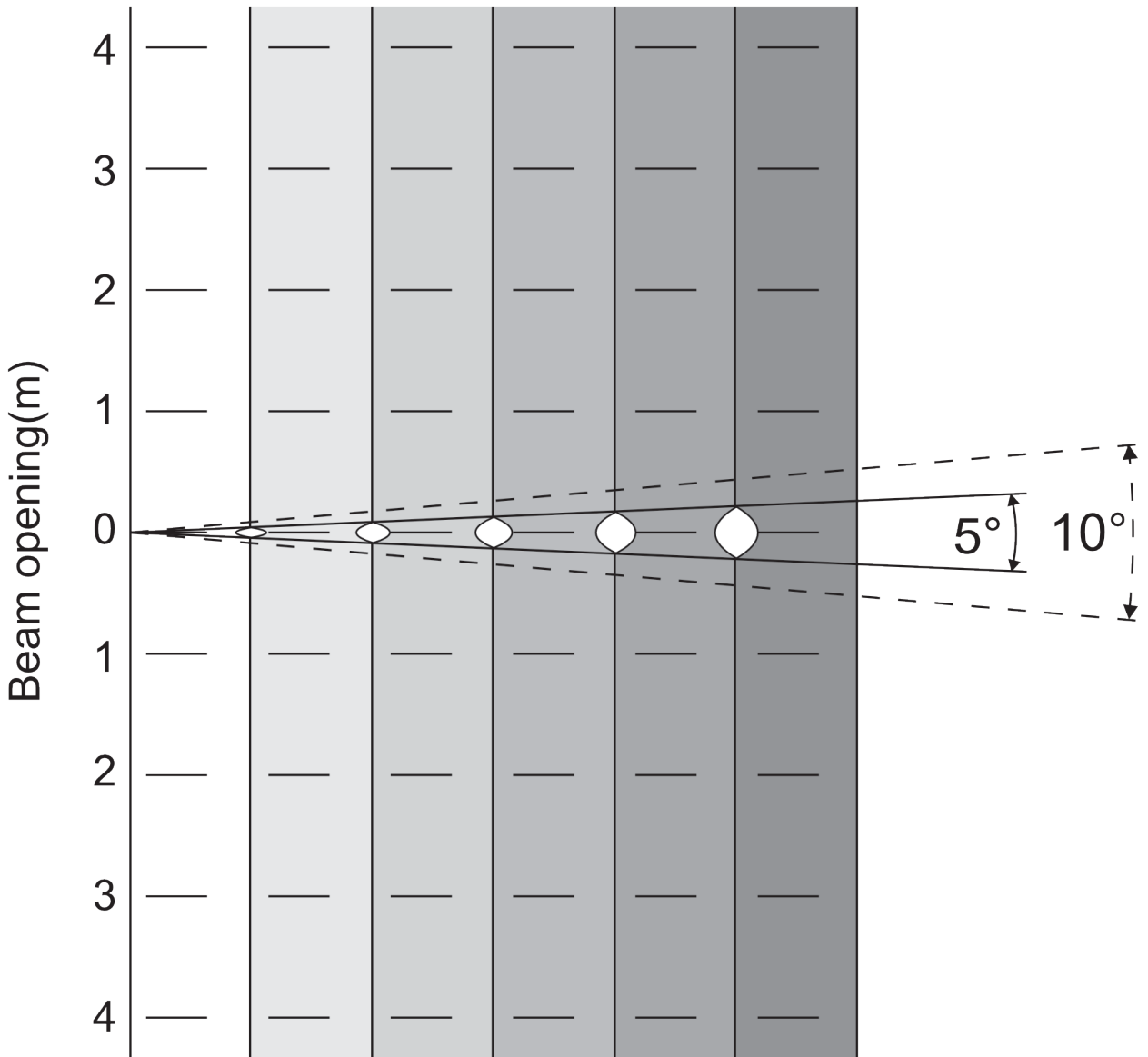

0	1	2	3	4	5
5° Diameter(m)	0.08	0.17	0.26	0.35	0.43
10° Diameter(m)	0.17	0.35	0.52	0.70	0.87

PHOTOMETRIC CHART

Beam angle 45°

Field angle 55°

Intensity(LUX)

Red LEDs	1053	312	143	83	57
Green LEDs	2643	764	450	203	139
Blue LEDs	535	155	72	42	28
White LEDs	3336	962	539	255	160
Full LEDs	6497	1865	868	507	334

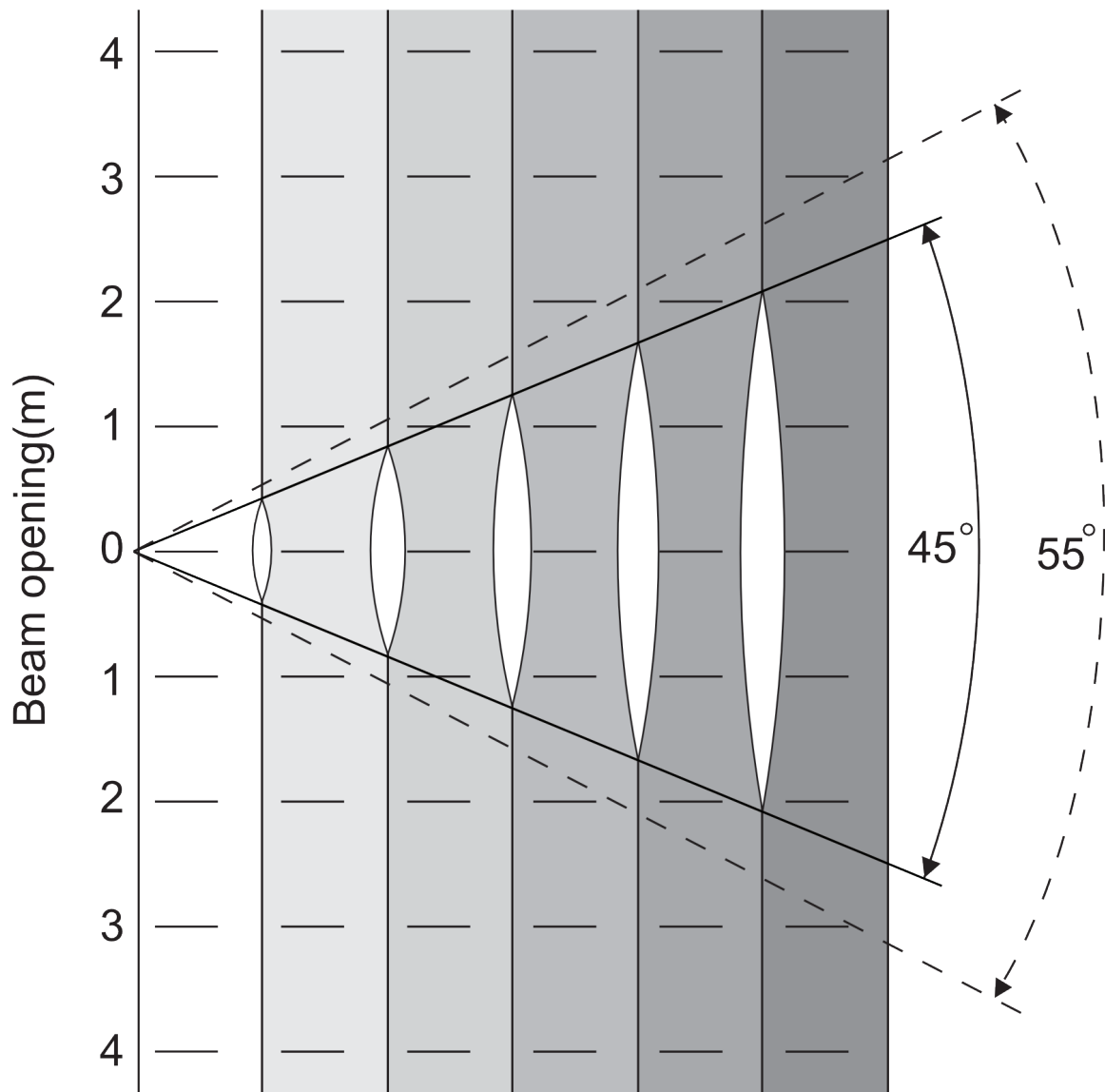

45° Diameter(m)	0.83	1.66	2.49	3.31	4.14
55° Diameter(m)	1.04	2.08	3.12	4.16	5.20

POWER CORD DAISY CHAIN

With this feature, you can connect the fixtures to one another using a IP-rated connector cable (sold separately). The quantity that can be connected is 15 fixtures maximum. After 15 fixtures you will need to use a new power outlet. They must be the same fixtures. **DO NOT** mix fixtures.

TROUBLE SHOOTING

Listed below are a few common problems the user may encounter, with solutions.

Unit not responding to DMX:

1. Check that the DMX cables are connected properly and are wired correctly (pin 3 is “hot”; on some other DMX devices pin 2 may be ‘hot’). Also, check that all cables are connected to the right connectors; it does matter which way the inputs and outputs are connected.

CLEANING

Due to fog residue, smoke, and dust cleaning the internal and external optical lenses must be carried out periodically to optimize light output.

1. Use normal glass cleaner and a soft cloth to wipe down the outside casing.
2. Clean the external optics with glass cleaner and a soft cloth every 20 days.
3. Always be sure to dry all parts completely before plugging the unit back in.

Cleaning frequency depends on the environment in which the fixture operates (i.e. smoke, fog residue, dust, dew).

LIMITED WARRANTY (USA ONLY)

- A. ADJ Products, LLC hereby warrants, to the original purchaser, ADJ Products, LLC products to be free of manufacturing defects in material and workmanship for a prescribed period from the date of purchase (see specific warranty periods below). This warranty shall be valid only if the product is purchased within the United States of America, including possessions and territories. It is the owner's responsibility to establish the date and place of purchase by acceptable evidence, at the time service is sought.
- B. For warranty service you must obtain a Return Authorization number (RA#) before sending back the product—please contact ADJ Products, LLC Service Department at 800-322-6337. Send the product only to the ADJ Products, LLC factory. All shipping charges must be pre-paid. If the requested repairs or service (including parts replacement) are within the terms of this warranty, ADJ Products, LLC will pay return shipping charges only to a designated point within the United States. If the entire instrument is sent, it must be shipped in its original package. No accessories should be shipped with the product. If any accessories are shipped with the product, ADJ Products, LLC shall have no liability whatsoever for loss of or damage to any such accessories, or for the safe return thereof.
- C. This warranty is void if the serial number has been altered or removed; if the product is modified in any manner which ADJ Products, LLC concludes, after inspection, affects the reliability of the product; if the product has been repaired or serviced by anyone other than the ADJ Products, LLC factory unless prior written authorization was issued to purchaser by ADJ Products, LLC; if the product is damaged because not properly maintained as set forth in the instruction manual.
- D. This is not a service contract, and this warranty does not include maintenance, cleaning or periodic check up. During the period specified above, ADJ Products, LLC will replace defective parts at its expense with new or refurbished parts, and will absorb all expenses for warranty service and repair labor by reason of defects in material or workmanship. The sole responsibility of ADJ Products, LLC under this warranty shall be limited to the repair of the product, or replacement thereof, including parts, at the sole discretion of ADJ Products, LLC. All products covered by this warranty were manufactured after August 15, 2012, and bear identifying marks to that effect.
- E. ADJ Products, LLC reserves the right to make changes in design and/or improvements upon its products without any obligation to include these changes in any products theretofore manufactured. No warranty, whether expressed or implied, is given or made with respect to any accessory supplied with products described above. Except to the extent prohibited by applicable law, all implied warranties made by ADJ Products, LLC in connection with this product, including warranties of merchantability or fitness, are limited in duration to the warranty period set forth above. And no warranties, whether expressed or implied, including warranties of merchantability or fitness, shall apply to this product after said period has expired. The consumer's and/or Dealer's sole remedy shall be such repair or replacement as is expressly provided above; and under no circumstances shall ADJ Products, LLC be liable for any loss or damage, direct or consequential, arising out of the use of, or inability to use, this product. This warranty is the only written warranty applicable to ADJ Products, LLC Products and supersedes all prior warranties and written descriptions of warranty terms and conditions heretofore published.

LIMITED WARRANTY PERIODS

Non LED Lighting Products = 1-Year (365 Days) (Including Special Effect Lighting, Intelligent Lighting, UV lighting, Strobes, Fog Machines, Bubble Machines, Mirror Balls, Par Cans, Trussing, Lighting Stands, Power/Data Distribution, etc. excluding LED and lamps)

Laser Products = 1-Year (365 Days) (excluding laser diodes which have a 6-Month Limited Warranty)

LED Products = 2-Year (730 Days) (excluding batteries which have a 180 Day Limited Warranty)

NOTE: 2-Year (730 Days) Limited Warranty ONLY applies to product purchased within the United States. StarTec Series = 1-Year (365 Days) (excluding batteries which have a 180 Day Limited Warranty)

ADJ DMX Controllers = 2 Year (730 Days)

American Audio Products = 1 Year (365 Days)

SPECIFICATIONS

Optical

- Light Source: 7 x 15 Watt Quad (RGBW) LEDs
- LED Life Expectancy: 50,000 Hrs
- Beam Angle: (5 to 45-degrees)
- Refresh Rate: 1.8KHz

Technical Features

- Compatible with ADJ's WiFLY Protocol
- Strobe (electronic)
- 64 built-in Color Macros
- 4 Operational Modes: Color Change Mode; Color Fade Mode; Auto (Program Run) Mode; and DMX-512 Mode
- 4-button LED Display on rear panel
- Electronic Dimming 0 – 100%
- Flicker Free
- WiFLY EXR DMX Range: 2,500 feet /700M (line of site)
- Wifly On/Off
- This unit is RDM compatible (Remote Device Management)
- Dual bracket yoke allows fixture to be hung or set on the ground

Connections

- Power & Power Pass through: IP65 Locking Power Connector In/Out
- Data: 3 Seatronic IP connection
- With Wired Digital Communication Network

Control

- 12 DMX Channel Modes
- 16 Selectable WiFLY Address Channels

Electrical

- Input Voltage: 100-240V 50Hz/60Hz (Auto Sensing)
- Power draw 120V 60Hz: 128W
- Power draw 220V 50Hz: 128W

Physical

- Dimensions (LxWxH): 10.5" x 13.75" x 15" / 270 x 350 x 380mm
- Weight: 25 lbs / 11 kg.
- Metal Black Housing
- IP 65

What's Included

- Power Cable (1M)
- Manual

Follow Us on:



facebook.com/americanadj
twitter.com/americanadj
youtube.com/adjlighting

ADJ Products, LLC
6122 S. Eastern Ave. Los Angeles, CA 90040 USA
Tel: 323-582-2650 / Fax: 323-725-6100
Web: www.adj.com / E-mail: info@americanadj.com

A.D.J. Supply Europe B.V.
Junostraat 2
6468 EW Kerkrade
Netherlands
service@adjgroup.eu / www.adj.eu
Tel: +31 45 546 85 00 / Fax: +31 45 546 85 99