



UB 6H



User Manual

©2023 ADJ Products, LLC all rights reserved. Information, specifications, diagrams, images, and instructions herein are subject to change without notice. ADJ Products, LLC logo and identifying product names and numbers herein are trademarks of ADJ Products, LLC. Copyright protection claimed includes all forms and matters of copyrightable materials and information now allowed by statutory or judicial law or hereinafter granted. Product names used in this document may be trademarks or registered trademarks of their respective companies and are hereby acknowledged. All non-ADJ Products, LLC brands and product names are trademarks or registered trademarks of their respective companies.

ADJ Products, LLC and all affiliated companies hereby disclaim any and all liabilities for property, equipment, building, and electrical damages, injuries to any persons, and direct or indirect economic loss associated with the use or reliance of any information contained within this document, and/or as a result of the improper, unsafe, insufficient and negligent assembly, installation, rigging, and operation of this product.

DOCUMENT VERSION

Please check www.adj.com for the latest revision/update of this document.

| Date | Document Version | Software Version \geq | DMX Channel Mode | Notes |
|----------|------------------|-------------------------|------------------|-----------------------------------|
| 08/04/17 | 1 | 1.01 | 6/10/12/18 | Initial Release |
| 03/12/21 | 2 | 1.03 | N/C | Update for Primary/Secondary Mode |
| 06/19/23 | 3 | N/C | N/C | Removed Airstream IR |

Europe Energy Saving Notice

Energy Saving Matters (EuP 2009/125/EC)

Saving electric energy is a key to help protecting the environment. Please turn off all electrical products when they are not in use. To avoid power consumption in idle mode, disconnect all electrical equipment from power when not in use. Thank you!

Unpacking: Thank you for purchasing the UB 6H by ADJ Products, LLC. Every UB 6H has been thoroughly tested and has been shipped in perfect operating condition. Carefully check the shipping carton for damage that may have occurred during shipping. If the carton appears to be damaged, carefully inspect your fixture for any damage and be sure all accessories necessary to operate the unit have arrived intact. In the event that damage has been found or parts are missing, please contact our toll free customer support number for further instructions. Do not return this unit to your dealer without first contacting customer support.

Introduction: The ADJ UB 6H is a DMX intelligent, LED bar fixture. This fixture can be used in a stand alone set up or connected in a Primary/Secondary set up. This fixture has six operating modes: Sound Active mode, Auto Run mode, Static Color mode, RGBWA+UV Dimmer mode, Built-In Program mode, and DMX control mode.

Customer Support: ADJ Products, LLC provides a customer support line, to provide set up help and to answer any questions that may arise during initial set up or operation. You may also visit us on the web at www.adj.com for any comments or suggestions. Service Hours are Monday through Friday 8:00 a.m. to 4:30 p.m. Pacific Standard Time.

| | |
|---------|-----------------|
| Voice: | (800) 322-6337 |
| Fax: | (323) 582-2941 |
| E-mail: | support@adj.com |

Warning! To prevent or reduce the risk of electrical shock or fire, do not expose this unit to rain or moisture.

Caution! There are no user serviceable parts inside this unit. Do not attempt any repairs yourself, as doing so will void your manufacturer's warranty. In the unlikely event that your unit requires service, please contact ADJ Products, LLC.

PLEASE recycle the shipping carton when ever possible.

UB 6H

Features

- Multi-Colors
- Six Operating Modes
- Electronic Dimming 0-100%
- Built in Microphone
- DMX-512 protocol
- 3-Pin DMX Connection
- 4 DMX Modes: 6 Channel Mode, 10 Channel Mode, 12 Channel Mode, & 18 Channel Mode.
- Magnetic Quick Align (See the **Magnetic Quick Align** section of this manual)
- ADJ UC IR compatible
- Multiple Unit Power Linking Capability (See the **Multiple Unit Power Linking** section of this manual for details)

UB 6H

Warranty Registration

The UB 6H carries a 2 year limited warranty. Please fill out the enclosed warranty card to validate your purchase. All returned service items, whether under warranty or not, must be freight pre-paid and accompanied by a return authorization (R.A.) number. The R.A. number must be clearly written on the outside of the return package. A brief description of the problem as well as the R.A. number must also be written down on a piece of paper included in the shipping carton. If the unit is under warranty, you must provide a copy of your proof of purchase invoice. You may obtain an R.A. number by contacting our customer support team on our customer support number. All packages returned to the service department not displaying an R.A. number on the outside of the package will be returned to the shipper.

UB 6H

Installation

The unit should be mounted using a mounting clamp (not provided), which should be attached to the mounting bracket that is provided with the unit. Always ensure that the unit is firmly fixed to avoid vibration and slipping while operating. Always ensure that the structure to which you are attaching the unit is secure and is able to support at least 10 times the unit's weight. Also, always use a safety cable that can hold at least 12 times the weight of the unit.

The equipment must be installed by a professional, and it must be installed in a place where it is out of the reach of people's grasp.

- To reduce the risk of electrical shock or fire, do not expose this unit to rain or moisture.
- Do not spill water or other liquids into or on to your unit.
- Do not attempt to operate this unit if the power cord is frayed or broken.
- Do not attempt to remove or break off the ground prong from the electrical cord. This prong is used to reduce the risk of electrical shock and fire in case of an internal short.
- Disconnect from main power before making any type of connection.
- Do not remove the cover for any reason. There are no user serviceable parts inside.
- Never operate this unit with the cover removed.
- Never plug this unit in to a dimmer pack.
- Always be sure to mount this unit in an area that will allow proper ventilation. Allow about 6” (15cm) between this device and a wall.
- Do not attempt to operate this unit if it has been damaged in any way.
- This unit is intended for indoor use only. Use of this product outdoors voids all warranties.
- During long periods of non-use, disconnect the unit from the power outlet.
- Always mount this unit in safe and stable matter.
- Power-supply cords should be routed so that they are not likely to be walked on or pinched by items placed upon or against them, paying particular attention to the point at which they exit from the unit.
- Cleaning - The fixture should be cleaned only as recommended by the manufacturer. See the **Cleaning** section of this manual for cleaning details.
- Heat - The appliance should be situated away from heat sources such as radiators, heat registers, stoves, or other appliances (including amplifiers) that produce heat.
- The fixture should be serviced by qualified service personnel when:
 - A. The power-supply cord or the plug has been damaged.
 - B. Objects have fallen onto, or liquid has been spilled into, the fixture.
 - C. The fixture has been exposed to rain or water.
 - D. The fixture does not appear to operate normally or exhibits a marked change in performance.

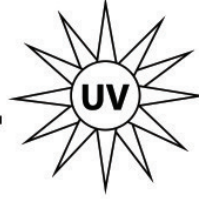
! CAUTION**HIGH
INTENSITY
ULTRAVIOLET
LIGHT****AVOID DIRECT EYE & SKIN EXPOSURE.
WEAR PROPER EYE & SKIN PROTECTION.
SEE MANUAL FOR SAFETY INSTRUCTIONS.****RISK GROUP 3 - RISK OF EXPOSURE TO ULTRAVIOLET (UV) RADIATION!****FIXTURE EMITS HIGH INTENSITY ULTRAVIOLET (UV) LIGHT AT A WAVELENGTH OF 390NM - 410NM.****WEAR PROPER EYE AND SKIN PROTECTION.****AVOID PROLONGED PERIODS OF EXPOSURE.****AVOID WEARING WHITE COLOR CLOTHING AND/OR USING (UV) PAINTS ON SKIN.****AVOID DIRECT EYE AND/OR SKIN EXPOSURE AT DISTANCES OF LESS THAN 11 feet (3.3m).****DO NOT OPERATE FIXTURE WITH DAMAGED OR MISSING EXTERNAL COVER PROTECTIVE LENS.****DO NOT LOOK DIRECTLY INTO THE (UV) LIGHT AND/OR VIEW (UV) LIGHT DIRECTLY WITH OPTICAL INSTRUMENTS THAT MAY CONCENTRATE THE LIGHT/RADIATION OUTPUT.****INDIVIDUALS SUFFERING FROM A RANGE OF EYE CONDITIONS, SUNLIGHT EXPOSURE DISORDERS, OR INDIVIDUALS USING PHOTSENSITIVE MEDICATION MAY EXPERIENCE DISCOMFORT IF EXPOSED TO THE ULTRAVIOLET (UV) LIGHT EMITTED FROM THIS FIXTURE.**

Power Supply: The ADJ UB 6H contains an automatic voltage switch, which will automatically sense the voltage when it is plugged into the power source. With this switch, there is no need to worry about the correct power voltage, and this unit can be plugged in anywhere.

DMX-512: DMX is short for Digital Multiplex. This is a universal protocol that is used as a form of communication between intelligent fixtures and controllers. A DMX controller sends DMX data instructions from the controller to the fixture. DMX data is sent as serial data that travels from fixture to fixture via the DATA “IN” and DATA “OUT” XLR terminals located on all DMX fixtures (most controllers only have a DATA “OUT” terminal).

DMX Linking: DMX is a language allowing all makes and models of different manufacturers to be linked together and operate from a single controller, as long as all fixtures and the controller are DMX compliant. To ensure proper DMX data transmission, try to use the shortest cable path possible when linking several DMX fixtures. The order in which fixtures are connected in a DMX line does not influence the DMX addressing. For example, a fixture assigned a DMX address of 1 may be placed anywhere in a DMX line: at the beginning, at the end, or anywhere in the middle. When a fixture is assigned a DMX address of 1, the DMX controller knows to send DATA assigned to address 1 to that unit, no matter where it is located in the DMX chain.

Data Cable (DMX Cable) Requirements (For DMX Operation): The UB 6H can be controlled via DMX-512 protocol. The UB 6H has 4 DMX channel modes; please see the **Channel Mode** sections of this manual for the different modes. Your unit and your DMX controller require a standard 3-pin XLR connector for data input and data output (Figure 1). We recommend Accu-Cable DMX cables. If you are making your own cables, be sure to use standard 110-120 Ohm shielded cable (This cable may be purchased at almost all pro lighting stores). Your cables should be made with a male XLR connector at one end of the cable and a female XLR connector at the other. Also remember that DMX cable must be daisy chained and cannot be split.



Figure 1

Notice: Be sure to follow figures two and three when making your own cables. Do not use the ground lug on the XLR connector. Do not connect the cable’s shield conductor to the ground lug or allow the shield conductor to come into contact with the XLR cable’s outer casing. Grounding the shield could cause a short circuit and result in erratic behavior.



Figure 2

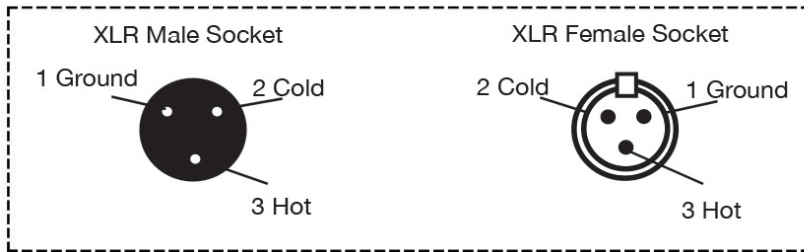
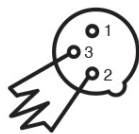

Figure 3

| XLR Pin Configuration | |
|-----------------------|----------------------------|
| Pin 1 = | Ground |
| Pin 2 = | Data Compliment (negative) |
| Pin 3 = | Data True (positive) |

Special Note: Line Termination. When longer runs of cable are used, you may need to use a terminator on the last unit to avoid erratic behavior. A terminator is a 110-120 ohm 1/4 watt resistor which is connected between pins 2 and 3 of a male XLR connector (DATA + and DATA -). This unit is inserted in the female XLR connector of the last unit in your daisy chain to terminate the line. Using a cable terminator (ADJ part number **Z-DMX/T**) will decrease the chances of erratic behavior.



Termination reduces signal errors and avoids signal transmission problems and interference. It is always advisable to connect a DMX terminal, (Resistance 120 Ohm 1/4 W) between PIN 2 (DMX-) and PIN 3 (DMX +) of the last fixture.

Figure 4

5-Pin XLR DMX Connectors. Some manufacturers use 5-pin DMX-512 data cables for DATA transmission in place of 3-pin. 5-pin DMX fixtures may be implemented in a 3-pin DMX line. When inserting standard 5-pin data cables into a 3-pin line, a cable adaptor must be used. These adaptors are readily available at most electronics stores. The chart below details a proper cable conversion.

| 3-Pin XLR to 5-Pin XLR Conversion | | |
|-----------------------------------|------------------------|---------------------|
| Conductor | 3-Pin XLR Female (Out) | 5-Pin XLR Male (In) |
| Ground/Shield | Pin 1 | Pin 1 |
| Data Compliment (- signal) | Pin 2 | Pin 2 |
| Data True (+ signal) | Pin 3 | Pin 3 |
| Not Used | | Do Not Use |
| Not Used | | Do Not Use |

LED Display On/Off:

To set the LED display to turn off after 10 seconds of inactivity, press the MODE button until “don” is displayed, then press the UP button until “doff” is displayed on the screen. Now the display will turn off after 10s. Press any button to turn the display on again.

LED Display Inversion:

Follow these instructions to flip the display 180° so that the display can be read when the unit is mounted upside down.

1. Plug the fixture in and press the MODE button until “dXX” is displayed. “XX” represents either “on” or “off”.
2. Press the SET UP button until “Stnd” is displayed.
3. Press the UP or DOWN buttons to “flip” the display 180°.

Operating Modes:

The UB 6H has six operating modes:

- Static Color Mode - There are 63 colors to choose from.
- RGBWA+UV Dimmer Mode - Choose one of the 6 colors to remain static, or adjust the intensity of each color to create a custom color.
- Built-In Program - There are 22 built-in programs to choose from with multiple adjustments.
- Auto Run - An auto program will run with adjustable fade speed and strobe.
- Sound-Active mode - The unit will react to sound, chasing through the built in programs.
- DMX control mode - This function will allow you to control each DMX trait with a standard DMX 512 controller.

Static Color Mode:

1. Plug the fixture in and press the MODE button until “CLXX” is displayed.
2. There are 63 colors to choose from. Select your desired color by pressing the UP and DOWN buttons. After you have selected your desired color you can activate strobing by pressing the SET UP button to enter the Flash (strobe) mode.
3. “FS.XX” will now be displayed, indicating that the device is now in Flash mode. The Flash can be adjusted between “FS.00” (flash off) to “FS.15” (fastest flash).

RGBWA & UV Dimmer Mode:

1. Plug the fixture in and press the MODE button until “r.XXX” is displayed. You are in Red dimming mode.
2. Press the UP and DOWN buttons to adjust intensity. After you have finished adjusting the intensity, or if you would like to skip to the next color, press the SET UP button.
3. When “G.XXX” is displayed you are in Green dimming mode. Press the UP and DOWN buttons to adjust intensity.
4. When “b.XXX” is displayed you are in Blue dimming mode. Press the UP and DOWN buttons to adjust intensity.
5. When “U.XXX” is displayed you are in White dimming mode. Press the UP and DOWN buttons to adjust intensity.
6. When “A.XXX” is displayed you are in Amber dimming mode. Press the UP and DOWN buttons to adjust intensity.
7. When “u.XXX” is displayed you are in UV dimming mode. Press the UP and DOWN buttons to adjust intensity.
8. After you have adjusted the colors to make your desired color you can then activate strobing by pressing the SET UP button to enter the strobe mode.
9. “FSXX” will be displayed, indicating that the device is now in strobe mode. The strobe can be adjusted between “00” (flash off) to “15” (fastest flash).

Auto Run Mode:

In this mode the fixture will run an auto program.

1. Plug the fixture in and press the MODE button until “AUTO” is displayed.
2. After you have activated Auto Run mode, press the SET UP button to adjust the fade time.
3. Once you press SET UP “Fd.XX” should be displayed. Use the UP or DOWN buttons to set the fade speed to either “Fd.00” (fade off) or between “Fd.01” (fastest speed) and “Fd.99” (slowest speed). After adjusting the fade speed, press SET UP if you wish to activate the Flash mode.
4. “FS.XX” will now be displayed, indicating that the device is now in Flash mode. The Flash can be adjusted between “FS.00” (flash off) to “FS.15” (fastest flash).

Built-In Program Mode:

1. Plug the fixture in and press the MODE button until “Pr.XX” is displayed. “XX” represents a number from 1-22. Use the UP or DOWN buttons to scroll through the 22 programs. Programs 21 and 22 have adjustable base and scrolling colors. Once you have found your desired program, press the SET UP button.
2. Pressing the SET UP button will display “SP.XX”. When this is displayed, you can adjust the running speed of your desired program. Use the UP or DOWN button to adjust the speed between “SP.01” (slowest) and “SP.99” (fastest). Once you have set your desired running speed, you can press the SET UP button to enter the Fade adjustment mode.
3. Pressing the SET UP button will display “Fd.XX”. When this is displayed, you can adjust the fade speed of your desired program. Use the UP or DOWN button to adjust the speed between “Fd.01” (fastest) and “Fd.99” (slowest) or “Fd.00” (Off). Once you have set your desired fade speed, you can press the SET UP button to enter the Flash (Strobe) mode.
4. After pressing SET UP, “FS.XX” will be displayed, indicating that the device is now in Flash mode. The Flash can be adjusted between “FS.00” (flash off) to “FS.15” (fastest flash).
 - **PROGRAMS 21 & 22** - If you have chosen programs 21 or 22, after the Flash mode, press the SET UP button. “C1.XX” will be displayed. This is the base color. Use the UP and DOWN buttons to scroll through the 7 colors. Once you have chosen your base color, press the SET UP button again so that “C2.XX” is displayed. This is the moving color. Use the UP and DOWN buttons to scroll through the 7 colors.

Sound Active Mode:

1. Plug the fixture in and press the MODE button until “SU.XX” is displayed. “XX” represents the sound sensitivity level.
2. Use the UP or DOWN buttons to adjust the sound sensitivity. “SU.00” is off, “SU.01” is the lowest sensitivity, and “SU.31” is the highest. After adjusting the sound sensitivity, press SET UP if you wish to activate the Flash mode.
3. “FS.XX” will now be displayed, indicating that the device is now in Flash mode. The Flash can be adjusted between “FS.00” (flash off) to “FS.15” (fastest flash).

DMX Mode:

Operating through a DMX controller gives you the freedom to create programs tailored to your own individual needs. This function also allows you to use your fixtures as spot lights. The UB 6H has 4 DMX modes: 6-channel mode, 10-channel mode, 12-channel mode, and 18-channel mode. See the **Channel Mode** sections of this manual for details.

1. This function will allow you to control each individual fixture’s traits with a standard DMX 512 controller.
2. To run your fixture in DMX mode, press the MODE button until “d.XXX” is displayed. “XXX” represents the currently used address. Use the UP or DOWN buttons to select your desired DMX address, then press the SETUP button so that “Ch.XX” is displayed.
3. Use the UP or DOWN buttons to scroll through the DMX Channel modes: “Ch06” for 6-channel mode, “Ch10” for 10-channel mode, “Ch12” for 12-channel mode, or “Ch18” for 18-channel mode.
4. After you have chosen your desired DMX channel mode, connect the fixture to any standard DMX controller via the XLR connections on the fixture and controller.

ADJ Remote Activation:

This function is used to activate and deactivate the IR sensor. When this function is activated, you can control the fixture the ADJ UC IR. Please see the **ADJ UC IR Operation** section of this manual for details on controls and functions.

1. Plug the fixture in and press the MODE button until “dXX” is displayed. “XX” represents either “on” or “oFF”.
2. Press the SET UP button until “IrXX” is displayed. “XX” represents either “on” or “oF”.
3. Press the UP or DOWN buttons to either activate the remote function (On) or deactivate it (Off).

DMX State:

This mode defines how the fixture will behave in the event that DMX signal is lost or interrupted. It also determines the operating mode that the fixture will default to when power is applied after a shutdown event.

1. Plug the fixture in and press the MODE button until “d.XXX” is displayed. “XXX” represents the current DMX address.
2. Press the SET UP button so that “nodn” is displayed. Use the UP and DOWN buttons to scroll through the DMX states.
 - “bLAC” (Blackout) - If the DMX signal is lost or interrupted, the unit will automatically go into stand by mode.
 - “LASt” (Last State) - If the DMX signal is lost or interrupted, the fixture will stay in the last DMX set up. If power is applied and this mode is set, the unit will automatically go into the last DMX set up.
 - “ProG” (Auto Run) - If the DMX signal is lost or interrupted, the unit will automatically go into Auto Run mode.
3. Use the UP and DOWN buttons to find your desired DMX state, then press SET UP to confirm and exit.

Dimmer Curve:

This is used to set the dimming curve used with DMX mode. See the **Dimming Curves** section of this manual for details.

1. Plug the fixture in and press the MODE button until the current DMX address is displayed.
2. Press the SET UP button until “dr-X” is displayed. “X” represents the displayed dimmer curve (0-4).
 - 0 - Standard
 - 1 - Stage
 - 2 - TV
 - 3 - Architectural
 - 4 - Theatre
3. Press the UP or DOWN buttons to scroll through and select your desired dimming curve.

Default Running Mode:

This is a default running mode. When this mode is activated all modes will return to their default settings and an Auto program will run.

1. Plug the fixture in and press the MODE button until “dXX” is displayed. “XX” represents either “on” or “off”.
2. Press the SET UP button until “dEFA” is displayed.
3. Press the UP and DOWN buttons at the same time.

UB 6H

Primary-Secondary Configuration**Primary-Secondary Configuration:**

This function will allow you to link units together to run in a Primary-Secondary mode, in which one unit will act as the controlling unit and the others will react to the controlling unit’s built-in programs. Any unit can act as a Primary or as a Secondary; however, only one unit in a set of linked units can be programmed to act as the Primary.

Primary-Secondary Connections and Settings:

1. Daisy chain your units together via the XLR connectors on the rear panels of each unit. Use standard XLR data cables to link your units together. Remember that the Male XLR connector is the input and the Female XLR connector is the output. The first unit in the chain (primary) will use the female XLR connector only, while the last unit in the chain will use the male XLR connector only.
2. Set the Primary unit to your desired operating mode and then connect the Secondary unit or units.
3. For the Secondary unit(s) press the MODE button until “Sec” is displayed. The Secondary unit(s) will now follow the Primary unit.

UB 6H

Multiple Unit Power Linking

This unit has the capability to link up to multiple other units of the same model type using the IEC input and output sockets.

The maximum number of fixtures that can be connected in this manner is as follows:

- ***16 fixtures @ 120V***
- ***29 fixtures @ 240V***

Once this number has been reached, a new power outlet must be used in order to accommodate any additional fixtures. All linked fixtures must be of the same make and model type. DO NOT mix fixtures!

The **UC IR** infrared remote gives you control of various functions. To control the fixture you must aim the remote at the front of the fixture and be within the maximum range of 30 feet. To use the ADJ UC IR you must first activate the fixture's infrared sensor, as described in the ***Operating Instructions*** section of this manual. Please note the unit must be set to Primary mode in order to work with the UC IR.

STAND BY - Pressing this button will blackout the fixture. Press the button again to return to the normal state.

FULL ON - Press this button to fully illuminate the unit. Press this button again to return the unit to its last mode of operation.

FADE/GOBO - This button activates fade mode. Use buttons 1-3 to adjust the fade speed.

“DIMMER +” and “DIMMER -” - Use these buttons to adjust the output intensity.

STROBE - Press this button to activate strobing. Use buttons 1-4 to adjust the strobe speed, with “1” being the slowest, and “4” being the fastest. Press STROBE button again to stop strobing.

COLOR - Press this button to activate color mode. Use buttons 1-9 to find your desired color.

1-9 - Use buttons 1-9 to select your desired color when color mode is active or your desired program when show mode is active. Use buttons 1-4 to select your desired strobe rate when strobing is active.

SOUND ON & OFF - Use the buttons to activate and deactivate sound active mode.

SHOW 0 - Press this button to activate show mode. Use buttons 1-9 to select your desired show. Press this button twice for show 10. Press button 1 twice for show 11.

| Channel | Value | Function |
|----------------|--------------|--------------------|
| 1 | 0 - 255 | RED 0% - 100% |
| 2 | 0 - 255 | GREEN 0% - 100% |
| 3 | 0 - 255 | BLUE 0% - 100% |
| 4 | 0 - 255 | WHITE 0% - 100% |
| 5 | 0 - 255 | AMBER 0% - 100% |
| 6 | 0 - 255 | UV 0% - 100% |

| Channel | Value | Function |
|---------|--|--|
| 1 | 0 - 255 | RED 0% - 100% |
| 2 | 0 - 255 | GREEN 0% - 100% |
| 3 | 0 - 255 | BLUE 0% - 100% |
| 4 | 0 - 255 | WHITE 0% - 100% |
| 5 | 0 - 255 | AMBER 0% - 100% |
| 6 | 0 - 255 | UV 0% - 100% |
| 7 | 0 - 255 | COLOR MACROS (See the Color Macro Chart section) |
| 8 | 0 - 31 32 - 63 64 - 95 96 - 127 128 - 159 160 - 191 192 - 223 224 - 255 | STROBING LED OFF LED ON STROBING SLOW - FAST LED ON PULSE STROBING SLOW - FAST LED ON RANDOM STROBING SLOW - FAST LED ON |
| 9 | 0 - 255 | MASTER DIMMER 0% - 100% |
| 10 | 0 - 20 21 - 40 41 - 60 61 - 80 81 - 100 101 - 255 | DIMMER CURVES STANDARD STAGE TV ARCHITECTURAL THEATRE DEFAULT TO UNIT SETTING |

| Channel | Value | Function |
|---------|---------|---|
| 1 | 0 - 255 | RED 0% - 100% |
| 2 | 0 - 255 | GREEN 0% - 100% |
| 3 | 0 - 255 | BLUE 0% - 100% |
| 4 | 0 - 255 | WHITE 0% - 100% |
| 5 | 0 - 255 | AMBER 0% - 100% |
| 6 | 0 - 255 | UV 0% - 100% |
| 7 | 0 - 255 | COLOR MACROS (See the Color Macro Chart section) |

| Channel | Value | Function |
|-----------|--------------|---------------------------|
| 8 | | PROGRAMS |
| | 0 - 15 | NO FUNCTION |
| | 16 - 25 | PROGRAM 1 |
| | 26 - 35 | PROGRAM 2 |
| | 36 - 45 | PROGRAM 3 |
| | 46 - 55 | PROGRAM 4 |
| | 56 - 65 | PROGRAM 5 |
| | 66 - 75 | PROGRAM 6 |
| | 76 - 85 | PROGRAM 7 |
| | 86 - 95 | PROGRAM 8 |
| | 96 - 105 | PROGRAM 9 |
| | 106 - 115 | PROGRAM 10 |
| | 116 - 125 | PROGRAM 11 |
| | 126 - 135 | PROGRAM 12 |
| | 136 - 145 | PROGRAM 13 |
| | 146 - 155 | PROGRAM 14 |
| | 156 - 165 | PROGRAM 15 |
| | 166 - 175 | PROGRAM 16 |
| | 176 - 185 | PROGRAM 17 |
| | 186 - 195 | PROGRAM 18 |
| 196 - 205 | PROGRAM 19 | |
| 206 - 215 | PROGRAM 20 | |
| 216 - 225 | PROGRAM 21 | |
| 226 - 235 | PROGRAM 22 | |
| 236 - 245 | AUTO RUN | |
| 246 - 255 | SOUND ACTIVE | |
| 9 | 0 - 255 | PROGRAM SPEED/SOUND SENSE |

| Channel | Value | Function |
|---------|-----------|-----------------------------|
| 10 | 0 - 31 | STROBING LED OFF |
| | 32 - 63 | LED ON |
| | 64 - 95 | STROBING SLOW - FAST |
| | 96 - 127 | LED ON |
| | 128 - 159 | PULSE STROBING SLOW - FAST |
| | 160 - 191 | LED ON |
| | 192 - 223 | RANDOM STROBING SLOW - FAST |
| | 224 - 255 | LED ON |
| 11 | 0 - 255 | MASTER DIMMER 0% - 100% |
| | | |
| 12 | 0 - 20 | DIMMER CURVES STANDARD |
| | 21 - 40 | STAGE |
| | 41 - 60 | TV |
| | 61 - 80 | ARCHITECTURAL |
| | 81 - 100 | THEATRE |
| | 101 - 255 | DEFAULT TO UNIT SETTING |
| | | |

Section Mode

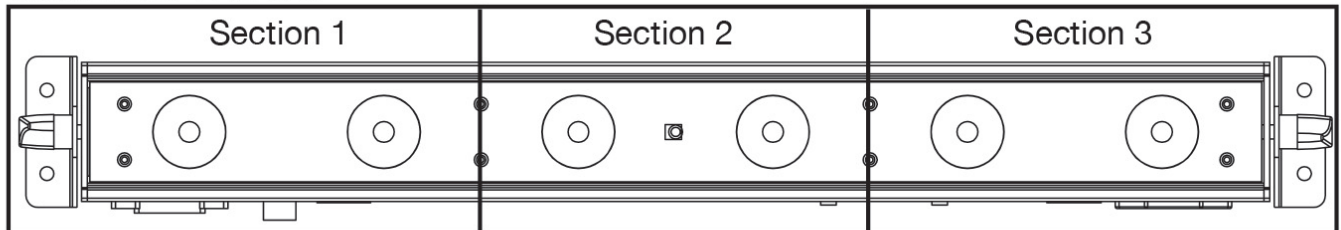

Section Mode refers to 18 Channel Mode.

| Channel | Value | Function |
|----------------|--------------|------------------------------|
| 1 | 0 - 255 | RED SECTION 1 0% - 100% |
| 2 | 0 - 255 | GREEN SECTION 1 0% - 100% |
| 3 | 0 - 255 | BLUE SECTION 1 0% - 100% |
| 4 | 0 - 255 | WHITE SECTION 1 0% - 100% |
| 5 | 0 - 255 | AMBER SECTION 1 0% - 100% |
| 6 | 0 - 255 | UV SECTION 1 0% - 100% |
| 7 | 0 - 255 | RED SECTION 2 0% - 100% |
| 8 | 0 - 255 | GREEN SECTION 2 0% - 100% |
| 9 | 0 - 255 | BLUE SECTION 2 0% - 100% |
| 10 | 0 - 255 | WHITE SECTION 2 0% - 100% |
| 11 | 0 - 255 | AMBER SECTION 2 0% - 100% |
| 12 | 0 - 255 | UV SECTION 2 0% - 100% |
| 13 | 0 - 255 | RED SECTION 3 0% - 100% |
| 14 | 0 - 255 | GREEN SECTION 3 0% - 100% |
| 15 | 0 - 255 | BLUE SECTION 3 0% - 100% |
| 16 | 0 - 255 | WHITE SECTION 3 0% - 100% |
| 17 | 0 - 255 | AMBER SECTION 3 0% - 100% |
| 18 | 0 - 255 | UV SECTION 3 0% - 100% |

| | | | |
|-------------|----------------|------------------|----------------------|
| 0-3=Off | 64-67=B+W | 128-131=G+B+W | 192-195=R+B+W+A |
| 4-7=Red | 68-71=B+A | 132-135=G+B+A | 196-199=R+B+W+UV |
| 8-11=Green | 72-75=B+UV | 136-139=G+B+UV | 200-203=R+B+A+UV |
| 12-15=Blue | 76-79=W+A | 140-143=G+W+A | 204-207=R+W+A+UV |
| 16-19=White | 80-83=W+UV | 144-147=G+W+UV | 208-211=G+B+W+A |
| 20-23=Amber | 84-87=A+UV | 148-151=G+A+UV | 212-215=G+B+W+UV |
| 24-27=UV | 88-91=R+G+B | 152-155=B+W+A | 216-219=G+B+A+UV |
| 28-31=R+G | 92-95=R+G+W | 156-159=B+W+UV | 220-223=G+W+A+UV |
| 32-35=R+B | 96-99=R+G+A | 160-163=B+A+UV | 224-227=B+W+A+UV |
| 36-39=R+W | 100-103=R+G+UV | 164-167=W+A+UV | 228-231=R+G+B+W+A |
| 40-43=R+A | 104-107=R+B+W | 168-171=R+G+B+W | 232-235=R+G+B+W+UV |
| 44-47=R+UV | 108-111=R+B+A | 172-175=R+G+B+A | 236-239=R+G+B+A+UV |
| 48-51=G+B | 112-115=R+B+UV | 176-179=R+G+B+UV | 240-243=R+G+W+A+UV |
| 52-55=G+W | 116-119=R+W+A | 180-183=R+G+W+A | 244-247=R+B+W+A=UV |
| 56-59=G+A | 120-123=R+W+UV | 184-187=R+G+W+UV | 248-251=G+B+W+A+UV |
| 60-63=G+UV | 124-127=R+A+UV | 188-191=R+G+A+UV | 252-255=R+G+B+W+A+UV |

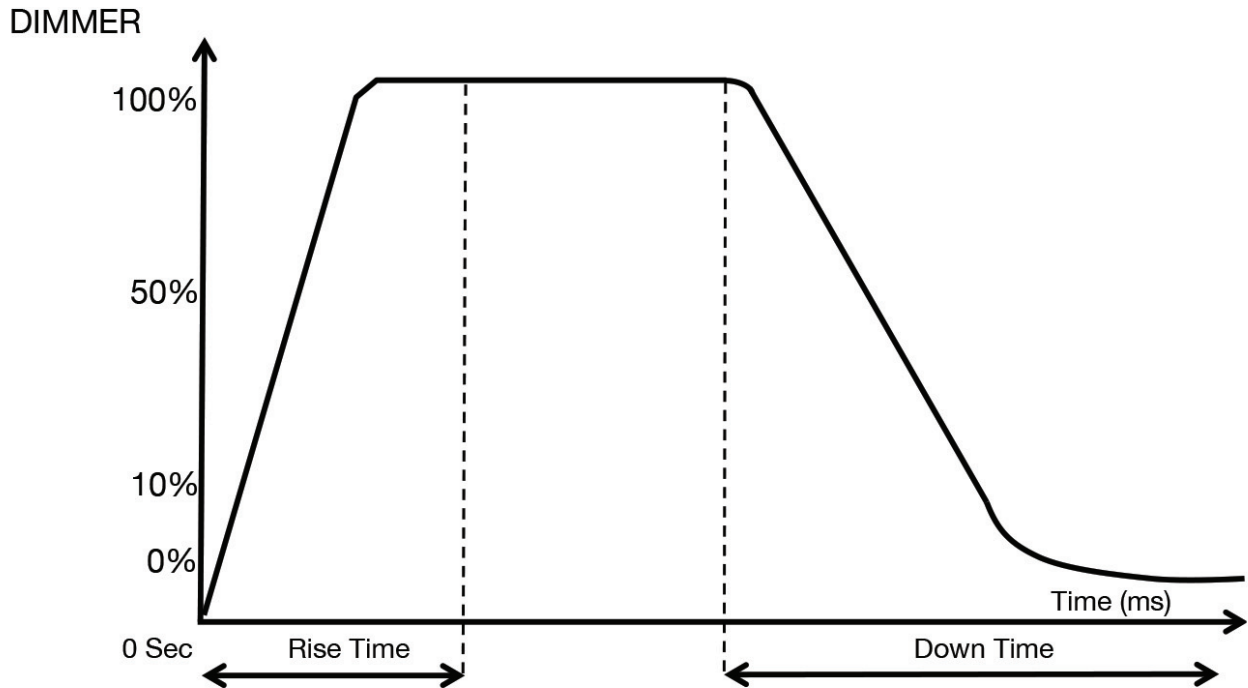

| Dimming Curve Ramp Effect | 0 sec Fade Time | | 1 sec Fade Time | |
|---------------------------|-----------------|----------------|-----------------|----------------|
| | Rise Time (ms) | Down Time (ms) | Rise Time (ms) | Down Time (ms) |
| Standard (default) | 0 | 0 | 0 | 0 |
| Stage | 780 | 1100 | 1540 | 1660 |
| TV | 1180 | 1520 | 1860 | 1940 |
| Architectural | 1380 | 1730 | 2040 | 2120 |
| Theatre | 1580 | 1940 | 2230 | 2280 |

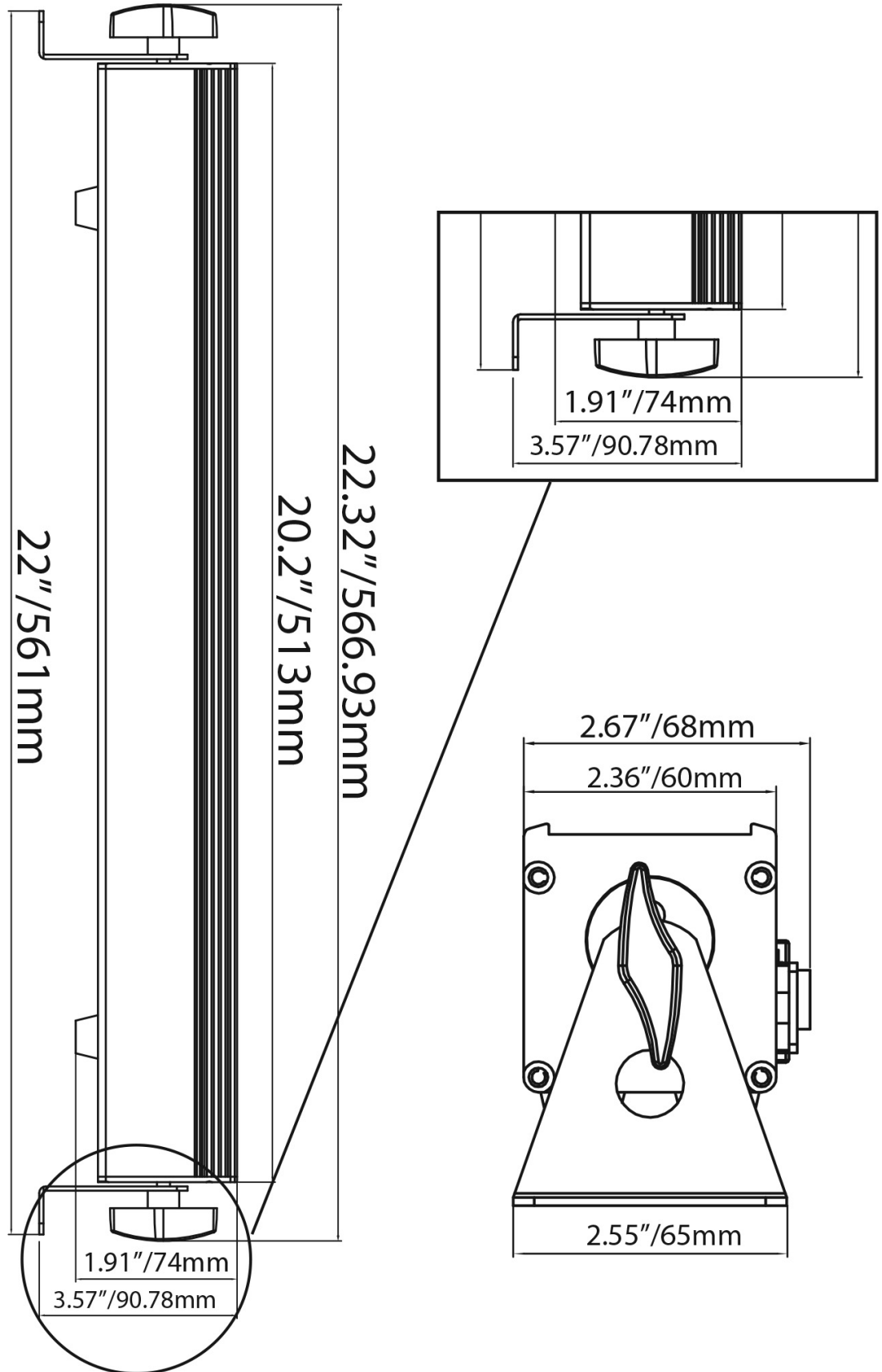

UB 6H

Magnetic Quick Align

This unit features a magnetic quick align feature which allows you to connect multiple fixtures securely in an end-to-end configuration. This feature is to be used only when the fixtures are placed on a flat surface such as a floor or stage for uplighting. To use this feature, unscrew the thumb screws on both ends of the fixture and remove both brackets. Position the fixtures on a flat surface and connect them end-to-end.

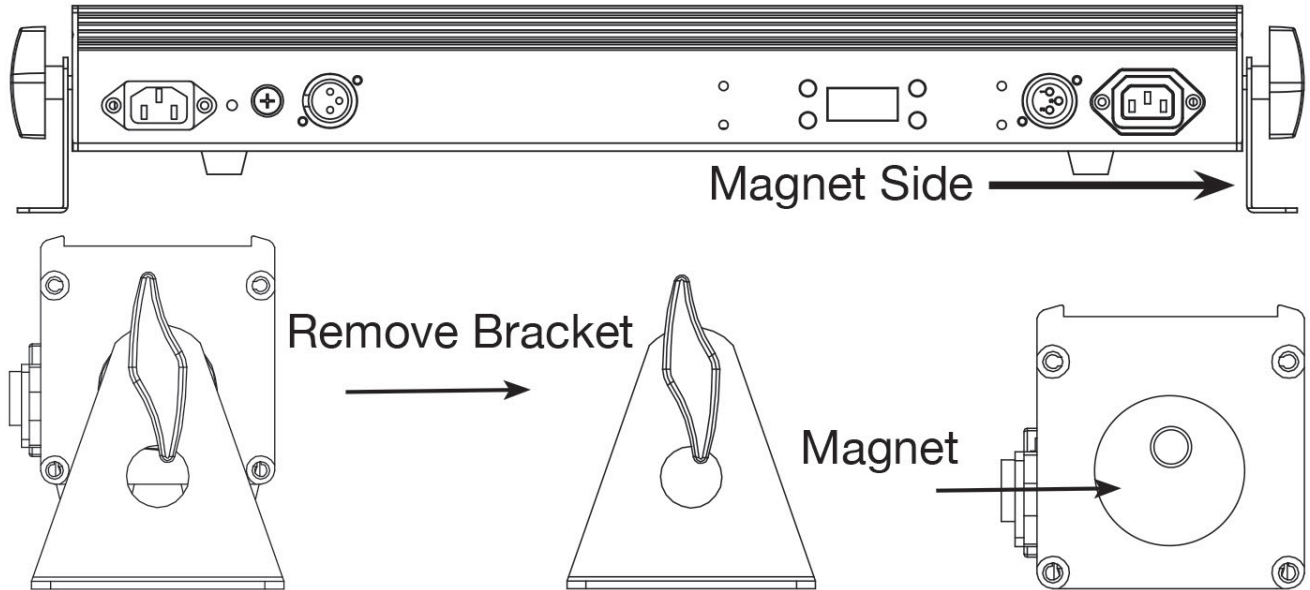

UB 6H

Fuse Replacement

Disconnect the unit from its power source, and remove the power cord from the unit. Use a flat head screwdriver to remove the fuse holder, remove the fuse located inside the fuse holder, and replace with the new fuse. Install the fuse holder and new fuse and secure it in place.

UB 6H

Trouble Shooting

Listed below are a few common problems the user may encounter, with suggested solutions.

Unit not responding to DMX:

Check that the DMX cables are connected and wired correctly (pin 3 is “hot”; on some other DMX devices, pin 2 may be ‘hot’). Also, check that all cables are connected to the right connectors, as the way that the inputs and outputs are connected will affect the operation of the device.

Unit does not respond to sound:

- Quiet or high pitched sounds will not activate the unit.
- Make sure that Sound Active mode is activated.

UB 6H

Cleaning

Due to fog residue, smoke, and dust, cleaning of the internal and external optical lenses must be carried out periodically to optimize light output.

- Use normal glass cleaner and a soft cloth to wipe down the outside casing.
- Clean the external optics with glass cleaner and a soft cloth every 20 days.
- Always be sure to dry all parts completely before plugging the unit back in.

Cleaning frequency depends on the environment in which the fixture operates (i.e. smoke, fog residue, dust, dew).

- A. ADJ Products, LLC hereby warrants, to the original purchaser, ADJ Products, LLC products to be free of manufacturing defects in material and workmanship for a prescribed period from the date of purchase (see specific warranty period on reverse). This warranty shall be valid only if the product is purchased within the United States of America, including possessions and territories. It is the owner's responsibility to establish the date and place of purchase by acceptable evidence, at the time service is sought.
- B. For warranty service, you must obtain a Return Authorization number (RA#) before sending the product back—please contact ADJ Products, LLC Service Department at 800-322-6337. Send the product only to the ADJ Products, LLC factory. All shipping charges must be prepaid. If the requested repairs or service (including parts replacement) are within the terms of this warranty, ADJ Products, LLC will pay return shipping charges only to a designated point within the United States. If the entire instrument is sent, it must be shipped in its original package and packaging material. No accessories should be shipped with the product. If any accessories are shipped with the product, ADJ Products, LLC shall incur no liability whatsoever for loss of or damage to any such accessories, nor for the safe return thereof.
- C. This warranty is void if the product serial number and/or labels are altered or removed; if the product is modified in any manner which ADJ Products, LLC concludes, after inspection, affects the reliability of the product; if the product has been repaired or serviced by anyone other than the ADJ Products, LLC factory unless prior written authorization was issued to purchaser by ADJ Products, LLC; if the product is damaged because it was not properly maintained as set forth in the product instructions, guidelines and/or user manual.
- D. This is not a service contract, and this warranty does not include maintenance, cleaning, or periodic checkup. During the period specified above, ADJ Products, LLC will replace defective parts at its expense with new or refurbished parts, and will absorb all expenses for warranty service and repair labor by reason of defects in material or workmanship. The sole responsibility of ADJ Products, LLC under this warranty shall be limited to the repair of the product, or replacement thereof, including parts, at the sole discretion of ADJ Products, LLC. All products covered by this warranty were manufactured after August 15, 2012, and bear identifying marks to that effect.
- E. ADJ Products, LLC reserves the right to make changes in design and/or improvements upon its products without any obligation to include these changes in any products theretofore manufactured.

No warranty, whether expressed or implied, is given or made with respect to any accessory supplied with products described above. Except to the extent prohibited by applicable law, all implied warranties made by ADJ Products, LLC in connection with this product, including warranties of merchantability or fitness, are limited in duration to the warranty period set forth above. And all warranties, whether expressed or implied, including warranties of merchantability or fitness, are limited in duration to the warranty period set forth above. The consumer's and/or dealer's sole remedy shall be such repair or replacement as is expressly provided above; and under no circumstances shall ADJ Product, LLC be liable for any loss and/or damage, direct and/or consequential arising out of the use of, and/or inability to use this product.

This warranty is the only written warranty applicable to ADJ Products, LLC products, and supersedes all prior warranties and written descriptions of warranty terms and conditions heretofore published.

MANUFACTURER'S LIMITED WARRANTY PERIODS:

- Non-LED Lighting Products = 1-Year (365 Days) (Including Special Effect Lighting, Intelligent Lighting, UV lighting, Strobes, Fog Machines, Bubble Machines, Mirror Balls, Par Cans, Trussing, Lighting Stands, Power/Data Distribution, etc. excluding LED and lamps)
- Laser Products = 1-Year (365 Days) (excluding laser diodes which have a 6-Month Limited Warranty)
- LED Products = 2-Year (730 Days) (excluding batteries which have a 180 Day Limited Warranty)
- NOTE: 2-Year (730 Days) Limited Warranty ONLY applies to product purchased within the United States.
- StarTec Series = 1-Year (365 Days) (excluding batteries which have a 180 Day Limited Warranty)
- ADJ DMX Controllers = 2 Year (730 Days)
- American Audio Products = 1 Year (365 Days)

UB 6H

Specifications

Model:

UB 6H

| | |
|-------------------|--|
| Voltage: | 100V ~ 240V / 50~60Hz |
| LEDs: | 6 x 6W 6-in-1 HEX LEDs |
| Beam Angle: | 40 Degrees |
| Working Position: | Any safe working position |
| Power Draw: | 30W |
| Power Linking: | 16 Fixtures Max. @ 120V 29 Fixtures Max. @ 240V |
| Fuse: | 2 Amp |
| Weight: | 3.5 Lbs. / 1.58 Kgs. |
| Dimensions: | 23" (L) x 4.5" (W) x 6.5" (H) 585 x 110 x 165mm |
| Colors: | RGBWA+UV Color Mixing |
| DMX Channels: | 4 DMX Modes: 6-channel mode, 10-channel mode, 12-channel mode, & 18-channel mode |
| Warranty: | 2 Years (730 days) Limited Warranty |

Please Note: Specifications and improvements in the design of this unit and this manual are subject to change without any prior written notice.

ADJ Products, LLC
6122 S. Eastern Ave. Los Angeles, CA 90040 USA Tel:
323-582-2650 / Fax: 323-725-6100
Web: www.adj.com / E-mail: info@adj.com

Follow Us On:



facebook.com/americandj
twitter.com/americandj
youtube.com/adjlighting

A.D.J. Supply Europe B.V.
Junostraat 2
6468 EW Kerkrade
Netherlands
service@adjgroup.eu / www.adj.com
Tel: +31 45 546 85 00 / Fax: +31 45 546 85 99

