

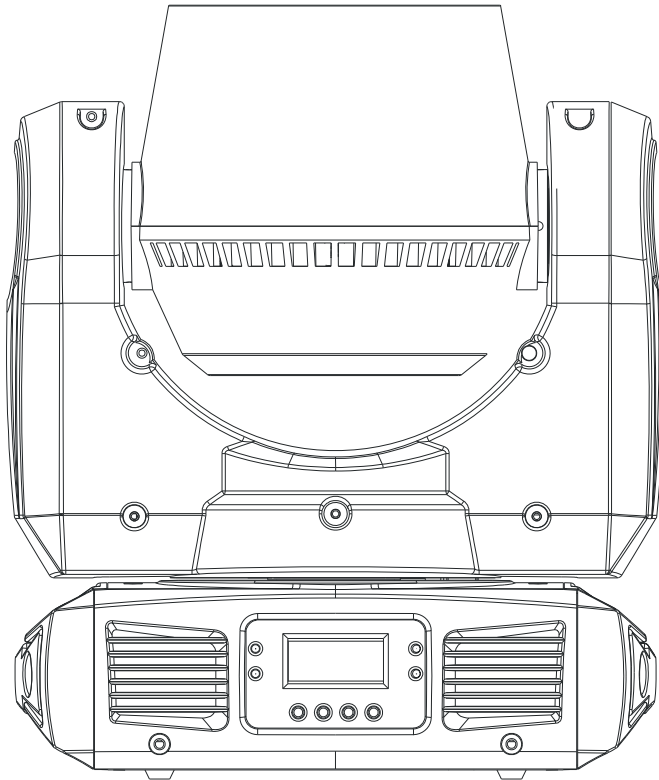

INNO COLOR BEAM Z7



User Instructions



©2015 ADJ Products, LLC all rights reserved. Information, specifications, diagrams, images, and instructions herein are subject to change without notice. ADJ Products, LLC logo and identifying product names and numbers herein are trademarks of ADJ Products, LLC. Copyright protection claimed includes all forms and matters of copyrightable materials and information now allowed by statutory or judicial law or hereinafter granted. Product names used in this document may be trademarks or registered trademarks of their respective companies and are hereby acknowledged. All non-ADJ Products, LLC brands and product names are trademarks or registered trademarks of their respective companies.

ADJ Products, LLC and all affiliated companies hereby disclaim any and all liabilities for property, equipment, building, and electrical damages, injuries to any persons, and direct or indirect economic loss associated with the use or reliance of any information contained within this document, and/or as a result of the improper, unsafe, insufficient and negligent assembly, installation, rigging, and operation of this product.

Europe Energy Saving Notice
Energy Saving Matters (EuP 2009/125/EC)
Saving electric energy is a key to help protecting the environment. Please turn off all electrical products when they are not in use. To avoid power consumption in idle mode, disconnect all electrical equipment from power when not in use. Thank you!

Inno Color Beam Z7

Introduction

Unpacking: Thank you for purchasing the Inno Color Beam Z7 by ADJ Products, LLC. Every Inno Color Beam Z7 has been thoroughly tested and has been shipped in perfect operating condition. Carefully check the shipping carton for damage that may have occurred during shipping. If the carton appears to be damaged, carefully inspect your fixture for any damage and be sure all accessories necessary to operate the unit has arrived intact. In the case damage has been found or parts are missing, please contact our toll free customer support number for further instructions. Do not return this unit to your dealer without first contacting customer support.

Introduction: The Inno Color Beam Z7 is part of ADJ's continuing pursuit for creating high quality affordable intelligent fixtures. The Inno Color Beam Z7 is a high performance, DMX intelligent, moving head LED fixture. This fixture is a great piece for retail stores, displays, mood, architectural, interior and exterior decoration, and clubs. This unit can be used as a stand alone, or in a Master/Slave configuration. The unit can also be controlled via DMX controller. This fixture is suitable for theaters, studios, retail stores, and other similar locations.

Customer Support: ADJ Products, LLC provides a toll free customer support line, to provide set up help and to answer any question should you encounter problems during your set up or initial operation. You may also visit us on the web at www.adj.com for any comments or suggestions. Service Hours are Monday through Friday 8:00 a.m. to 4:30 p.m. Pacific Standard Time.

Voice: (800) 322-6337

Fax: (323) 582-2941

E-mail: support@americandj.com

To purchase parts online visit <http://parts.americandj.com>

Warning! To prevent or reduce the risk of electrical shock or fire, do not expose this unit to rain or moisture.

Caution! There are no user serviceable parts inside this unit. Do not attempt any repairs yourself, doing so will void your manufactures warranty. In the unlikely event your unit may require service please contact ADJ Products, LLC.

PLEASE recycle the shipping carton when ever possible.

Inno Color Beam Z7

General Instructions

To optimize the performance of this product, please read these operating instructions carefully to familiarize yourself with the basic operations of this unit. These instructions contain important safety information regarding the use and maintenance of this unit. Please keep this manual with the unit, for future reference.

Inno Color Beam Z7

Features

- RGBW Color Mixing
- 7 x 10W 4-in1 LEDs
- Color Strobe Effect
- Color Mix Effect
- Pan/Tilt Inversion
- Electronic Dimming 0-100%
- Dimmer Curve
- Built in Microphone
- DMX-512 protocol
- 14 DMX Channels
- 3 Operating Modes - Sound Active, Show Mode, or DMX Control
- Power Cord Daisy Chaining (See Section Below)

Inno Color Beam Z7

Power Cord Daisy Chaining

With this feature you can connect the fixtures to one another using the IEC input and output sockets. The quantity that can be connected is 4 fixtures maximum for 120V and 8 fixtures maximum for 240V. After the maximum fixtures has been reached you will need to use a new power outlet. They must be the same fixtures. DO NOT mix fixtures.

Inno Color Beam Z7

Warranty Registration

The Inno Color Beam Z7 carries a 2 year (730 days) limited warranty. Please fill out the enclosed warranty card to validate your purchase and warranty. You may also register your product online at www.americandj.com. All returned service items whether under warranty or not, must be freight pre-paid and accompany a return authorization (R.A.) number. If the unit is under warranty you must provide a copy of your proof of purchase invoice. Please contact ADJ customer support for a R.A. number.

- To reduce the risk of electrical shock or fire, do not expose this unit rain or moisture
- Do not spill water or other liquids into or on to your unit.
- Be sure that the local power outlet match that of the required voltage for your unit.
- Do not attempt to operate this unit if the power cord has been frayed or broken. Do not attempt to remove or break off the ground prong from the electrical cord. This prong is used to reduce the risk of electrical shock and fire in case of an internal short.
- Disconnect from main power before making any type of connection.
- Do not remove the cover under any conditions. There are no user serviceable parts inside.
- Never operate this unit when it's cover is removed.
- Never plug this unit in to a dimmer pack
- Always be sure to mount this unit in an area that will allow proper ventilation. Allow about 6" (15cm) between this device and a wall.
- Do not attempt to operate this unit, if it becomes damaged.
- This unit is intended for indoor use only, use of this product outdoors voids all warranties.
- During long periods of non-use, disconnect the unit's main power.
- Always mount this unit in safe and stable matter.
- Power-supply cords should be routed so that they are not likely to be walked on or pinched by items placed upon or against them, paying particular attention to the point they exit from the unit.
- Cleaning -The fixture should be cleaned only as recommended by the manufacturer. See page 22 for cleaning details.
- Heat -The appliance should be situated away from heat sources such as radiators, heat registers, stoves, or other appliances (including amplifiers) that produce heat.
- The fixture should be serviced by qualified service personnel when:
 - A. The power-supply cord or the plug has been damaged.
 - B. Objects have fallen, or liquid has been spilled into the appliance.
 - C. The appliance has been exposed to rain or water.
 - D. The appliance does not appear to operate normally or exhibits a marked change in performance.

When installing the unit, the trussing or area of installation must be able to hold 10 times the weight without any deformation. When installing the unit must be secured with a secondary safety attachment, e.g. and appropriate safety cable. Never stand directly below the unit when mounting, removing, or servicing the unit.

Overhead mounting requires extensive experience, including calculating working load limits, installation material being used, and periodic safety inspection of all installation material and unit. If you lack these qualifications, do not attempt the installation yourself.

These installation should be checked by a skilled person once a year.

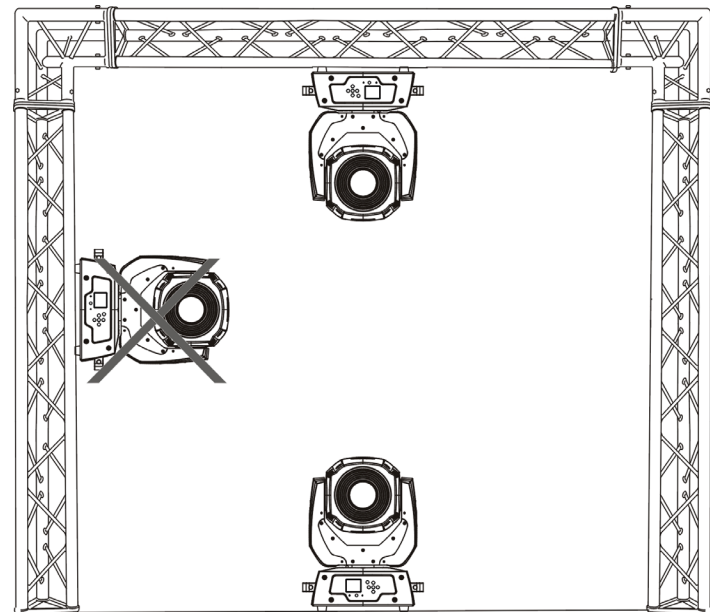

The Inno Color Beam Z7 is fully operational in two different mounting positions, hanging upside-down from a ceiling or set on a flat level surface. To avoid internal damage to the unit, never mount the unit on its side as illustrated above. Be sure this fixture is kept at least 0.5m away from any flammable materials (decoration etc.). Always use and install the supplied safety cable as a safety measure to prevent accidental damage and/or injury in the event the clamp fails (see next page). Never use the carrying handles for secondary attachment.

NOTICE: The suitable environmental temperature for this lighting fixture is between -25° C to 45° C. Do not place this lighting fixture in an environment where the temperatures are under or above the temperatures stated above. This will allow the fixture to run at its best and help prolong the fixture life.

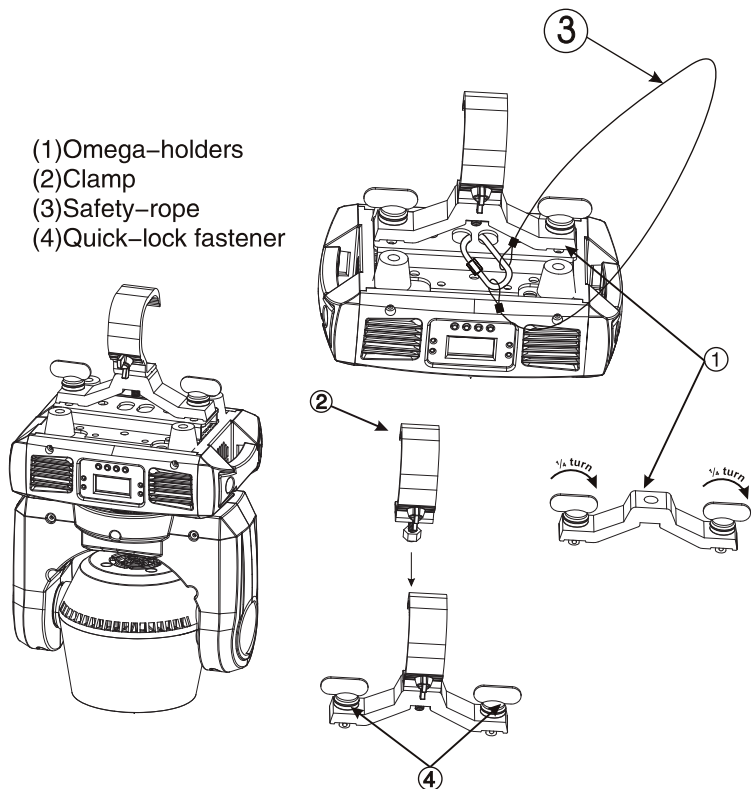

Screw one clamp via a M12 screw and nut onto the Omega holder. Insert the quick-lock fasteners of the first Omega holder into the respective holes on the bottom of the Inno Color Beam Z7. Tighten the quick-lock fasteners fully clockwise. Pull the safety-cable through the two slots located on the base underneath the Omega holder and then over the trussing system or a safe fixation spot. Insert the end in the carabine and tighten the safety screw.

Power Supply: The ADJ Inno Color Beam Z7 contains a automatic voltage switch, which will auto sense the voltage when it is plugged into a power source. With this switch there is no need to worry about the correct power voltage, this unit can be plugged in anywhere.

DMX-512: DMX is short for Digital Multiplex. This is a universal protocol used as a form of communication between intelligent fixtures and controllers. A DMX controller sends DMX data instructions from the controller to the fixture. DMX data is sent as serial data that travels from fixture to fixture via the DATA “IN” and DATA “OUT” XLR terminals located on all DMX fixtures (most controllers only have a DATA “OUT” terminal).

DMX Linking: DMX is a language allowing all makes and models of different manufactures to be linked together and operate from a single controller, as long as all fixtures and the controller are DMX compliant. To ensure proper DMX data transmission, when using several DMX fixtures try to use the shortest cable path possible. The order in which fixtures are connected in a DMX line does not influence the DMX addressing. For example; a fixture assigned a DMX address of 1 may be placed anywhere in a DMX line, at the beginning, at the end, or anywhere in the middle. When a fixture is assigned a DMX address of 1, the DMX controller knows to send DATA assigned to address 1 to that unit, no matter where it is located in the DMX chain.

Data Cable (DMX Cable) Requirements (For DMX Operation):

The Inno Color Beam Z7 can be controlled via DMX-512 protocol. The Inno Color Beam Z7 is a 14 Channel DMX unit. The DMX address is set on the front panel of the Inno Color Beam Z7. Your unit and your DMX controller require a approved DMX-512 110 Ohm Data cable for data input and data output (Figure 1). We recommend Accu-Cable DMX cables. If you are making your own cables, be sure to use standard 110-120 Ohm shielded cable (This cable may be purchased at almost all professional sound and lighting stores). Your cables should be made with a male and female XLR connector on either end of the cable. Also remember that DMX cable must be daisy chained and cannot be split.



Figure 1

Notice: Be sure to follow figures two and three when making your own cables. Do not use the ground lug on the XLR connector. Do not connect the cable's shield conductor to the ground lug or allow the shield conductor to come in contact with the XLR's outer casing. Grounding the shield could cause a short circuit and erratic behavior.

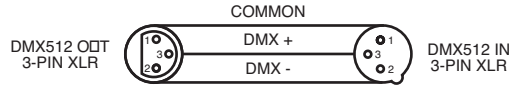

Figure 2



Figure 3

XLR Pin Configuration	
Pin 1 =	Ground
Pin 2 =	Data Compliment (negative)
Pin 3 =	Data True (positive)

Special Note: Line Termination. When longer runs of cable are used, you may need to use a terminator on the last unit to avoid erratic behavior. A terminator is a 90-120 ohm 1/4 watt resistor which is connected between pins 2 and 3 of a male XLR connector (DATA + and DATA -). This unit is inserted in the female XLR connector of the last unit in your daisy chain to terminate the line. Using a cable terminator (ADJ part number Z-DMX/T) will decrease the possibilities of erratic behavior.



Termination reduces signal errors and avoids signal transmission problems and interference. It is always advisable to connect a DMX terminal. (Resistance 120 Ohm 1/4 W) between PIN 2 (DMX-) and PIN 3 (DMX +) of the last fixture.

Figure 4

5-Pin XLR DMX Connectors. Some manufactures use 5-pin XLR connectors for DATA transmission in place of 3-pin. 5-pin XLR fixtures may be implemented in a 3-pin XLR DMX line. When inserting standard 5-pin XLR connectors in to a 3-pin line a cable adaptor must be used, these adaptors are readily available at most electric stores. The chart below details a proper cable conversion.

3-Pin XLR to 5-Pin XLR Conversion		
Conductor	3-Pin XLR Female (Out)	5-Pin XLR Male (In)
Ground/Shield	Pin 1	Pin 1
Data Compliment (- signal)	Pin 2	Pin 2
Data True (+ signal)	Pin 3	Pin 3
Not Used		Do Not Use
Not Used		Do Not Use

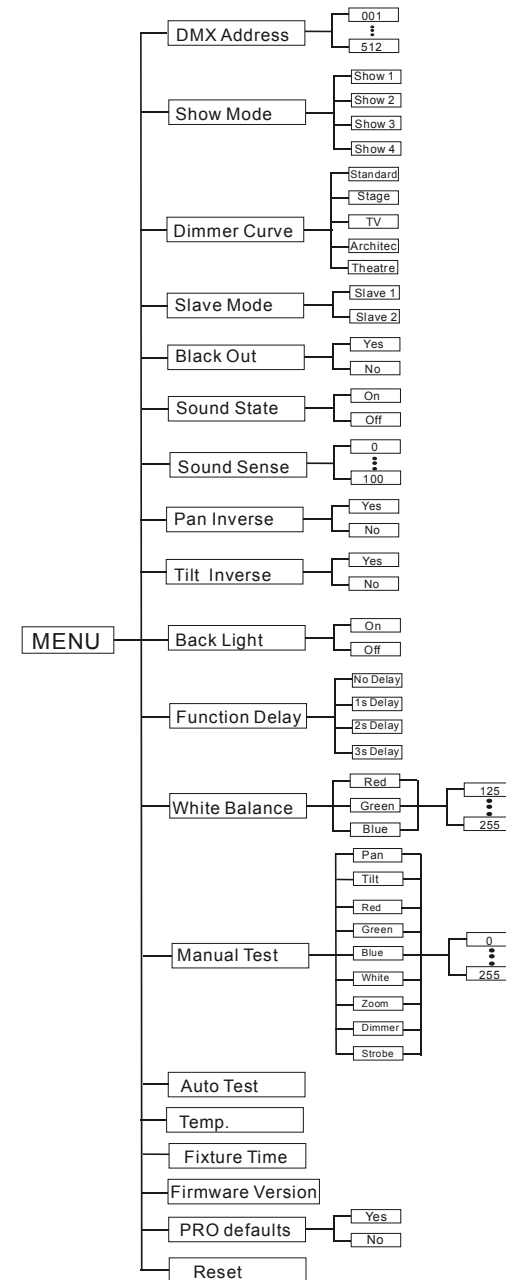

DMX Address - Set the DMX Address -

1. Press the MENU button until “DMX Address” is displayed, press ENTER.
2. “X” will now be displayed, “X” represents the displayed address. Press the UP or DOWN buttons to find your desired address.
3. Press ENTER to confirm, and then press and hold the MENU button for at least three seconds to assign.

Show Mode - Show modes 1 - 4 (Factory Shows).

1. Press the MENU button until “Show Mode” is displayed, press ENTER.
2. “Show X” will now be displayed, “X” representing a number between 1-4. Press the UP or DOWN buttons to find your desired show and press ENTER to confirm. After pressing ENTER, press and hold the MENU button for at least 3 seconds to activate.

Dimmer Curve - In this mode you can select the dimmer curve.

1. Press the MENU button until “Dimmer Curve” is displayed, press ENTER.
2. The current dimmer curve will be displayed.
3. Press the UP or DOWN buttons to find your desired dimmer curve and press ENTER to confirm.

Slave Mode - This will let you set unit as a master or slave in a master/slave configuration.

1. Press the MENU button until “Slave Mode” is displayed, press ENTER. Either “Slave 1” or “Slave 2” will be displayed.
2. Press the UP or DOWN buttons until your desired slave mode

is displayed, press ENTER to confirm.

NOTE: In a Master/Slave configuration you can make one fixture the Master and then set the next fixture to “Slave 2”, the fixtures will now have contrast movement to each other.

Black Out - This will activate/deactivate blackout

1. Press the MENU button until “Black Out” is displayed, press ENTER.
2. Either “Yes” or “No” will now be displayed. Press the UP or DOWN buttons to toggle between “Yes” and “No”.
3. Press ENTER to confirm your setting.

Sound State - In this mode the unit will run in sound active mode.

1. Press the MENU button until “Sound State” is displayed, press ENTER.
2. Either “On” or “Off” will now be displayed. Use the UP or DOWN buttons to toggle between “On” and “Off”.
3. Press ENTER to confirm your selection, the press and hold the MENU button to activate.

Sound Sense - In this mode you can adjust the sound sensitivity of the sound active mode.

1. Press the MENU button until “Sound Sense” is displayed, press ENTER.
2. Press the UP or DOWN buttons to adjust the sensitivity level. The sensitivity level can be adjusted between 0 (the lowest) and 100 (most sensitive).
3. Press ENTER to set you desired level.

Pan Inverse - Pan Inversion

1. Press the MENU button until “Pan Inverse” is displayed, press ENTER. Either “Yes” or “No” will be displayed.
2. To activate the Pan inversion press the UP or DOWN buttons until “Yes” is displayed, press ENTER to confirm. To deactivate Pan inversion, select “No” and press Enter.

Tilt Inverse - Tilt Inversion

1. Press the MENU button until “Tilt Inverse” is displayed, press ENTER. Either “Yes” or “No” will be displayed.
2. To activate the Tilt inversion press the UP or DOWN buttons until “Yes” is displayed, press ENTER to confirm. To deactivate Tilt inversion, select “No” and press Enter.

Back Light - With this function you can make the backlight automatically turn off after one minute.

1. Press the MENU button until “Back Light” is displayed, press ENTER.
2. Either “ON” or “OFF” will now be displayed. Press the UP or DOWN buttons to select “ON” to keep the backlight on at all times, or “OFF” to allow the backlight to turn off after 2 minutes. Press any button to turn the backlight on again.
3. Press ENTER to confirm.

Function Delay - With this function the blackout function under 14 Channel mode can be delayed.

1. Press the MENU button until “Function Delay” is displayed, press ENTER.
2. Either “No Delay” or time between 1s - 3s will be displayed.

This number represents the delay setting. Use the UP and DOWN buttons to adjust the blackout delay.

Example: If the delay is set to 3 seconds, when you are in 14 Channel mode under DMX control, and the channel 12 values are between 226-235, the fixture will move, and then blackout after 3 seconds.

3. Press ENTER to confirm.

White Balance - With this function you can adjust the RGB colors to make your desired color.

1. Press the MENU button until “White Balance” is displayed, press ENTER.
2. Use the UP or DOWN buttons to find the color you wish to adjust.
3. Once you find the color you want to adjust press ENTER, the displayed value will begin to flash. Use the UP or DOWN buttons to adjust the value. Once you have made your adjustment press ENTER.
4. Repeat steps 2-3 until satisfied.

Manual Test - With this function you can manually test the individual features.

1. Press the MENU button until “Manual Test” is displayed, press ENTER.
2. Use the UP or DOWN buttons to find the functions or colors that you wish to test. You can test the strobe function, dimmer, and zoom.
3. Once you find a function or color you wish to test, press the ENTER button, the displayed value will begin to flash. You can now adjust the values by pressing the UP and DOWN buttons.

Once you have finished testing press the ENTER button.

4. To exit the manual test mode, press the MENU button.

Auto Test - This function will run a self test program.

1. Press the MENU button until “Auto Test” is displayed, press ENTER.
2. The fixture will now run a self test. Press the MENU button to exit.

Temp. - With this function you can display the running temperature of the unit.

1. Press the MENU button until “Temp.” is displayed, press ENTER.
2. The current running temperature of the fixture will now be displayed. Press MENU to exit.

Fixture Time - With this function you can display the running time of the unit.

1. Press the MENU button until “Fixture Time” is displayed, press ENTER.
2. The running time of the fixture will now be displayed. Press MENU to exit.

Firmware Version - This will display the software version

1. Press the MENU button until “Firmware Version” is displayed. Press the ENTER button and the software version will be displayed.
2. Press the MENU button to leave this function.

PRO Default - This function will restore the factory settings.

1. Press the MENU button until “PRO Default” is displayed, press ENTER.
2. Either “YES” or “NO” will now be displayed. Press the UP or DOWN buttons to select “YES” to switch back to default settings, and press ENTER.

Reset - Use this function to reset the motors.

1. Tap the MENU button until “Reset” is displayed, press ENTER.
2. The fixture will now reset the motors.

Stand by	The unit blackout		
<i>Function</i>	1. Sync. Strobe 2. 2 light strobe 3. sound strobe	Select Show 1-4	1. Hold to change Master Pan position 2. Hold to change Master Tilt position 3. Hold to change Master Dimmer 4. Hold to change Slave Pan position 5. Hold to change Slave Tilt position 6. Hold to change Slave Dimmer
<i>Mode</i>	<i>Sound (LED off)</i>	<i>LED on</i>	<i>LED fast blinking</i>

Inno Color Beam Z7**Universal DMX Control**

Universal DMX Control: This function allows you to use a Elation® universal DMX-512 controller to control the chases and patterns, dimmer and strobe. A DMX controller allows you to create unique programs tailored to your individual needs. The Inno Color Beam Z7 has 14 DMX Channels.

1. This function will allow you to control each individual fixture's traits with a standard DMX 512 controller. See pages 17-20 for the DMX traits.
2. To run your fixture in DMX mode, set your desired DMX address following the directions on page 10, and the set-up specifications that come with your DMX controller.
3. Plug in the fixture via the XLR connections to any standard DMX controller.
4. For longer cable runs (more than a 100 feet) use a terminator on the last fixture.

Inno Color Beam Z7**Master-Slave Configuration**

Master-Slave Configuration: This function will allow you to link up to 16 units together and operate without a controller. The units will be sound activated. In Master-Slave operation one unit will act as the controlling unit and the others will react to the controlling units programs. Any unit can act as a Master or as a Slave.

1. Using approved DMX data cables, daisy chain your units together via the XLR connector on the rear of the units. Remember the Male XLR connector is the input and the Female XLR connector is the output. The first unit in the chain (master) will use the female XLR connector only - The last unit in the chain will use the male XLR connector only. For longer cable runs we suggest a terminator at the last fixture.
2. Set the Master unit to your desired operating mode.
3. On the slave units press the MENU button until "Slave Mode" is displayed, and Press ENTER. Choose either "Slave 1" or "Slave 2" and press ENTER. See page 11 for more info.
4. The slave units will now follow the Master unit.

Inno Color Beam Z7**14 Channel Mode**

Channel	Value	Function
1	0 - 255	PAN 0° - 540°
2	0 - 255	PAN FINE
3	0 - 255	TILT 0° - 220°
4	0 - 255	TILT FINE
5	0 - 255	RED 0% - 100%
6	0 - 255	GREEN 0% - 100%
7	0 - 255	BLUE 0% - 100%
8	0 - 255	WHITE 0% - 100%
9	0 1 - 4 5 - 8 9 - 12 13 - 16 17 - 20 21 - 24 25 - 28 29 - 32 33 - 36 37 - 40 41 - 44 45 - 48 49 - 52 53 - 56 57 - 60 61 - 64 65 - 68 69 - 72	COLOR MACROS OFF MACRO 1 MACRO 2 MACRO 3 MACRO 4 MACRO 5 MACRO 6 MACRO 7 MACRO 8 MACRO 9 MACRO 10 MACRO 11 MACRO 12 MACRO 13 MACRO 14 MACRO 15 MACRO 16 MACRO 17 MACRO 18

Inno Color Beam Z7		14 Channel Mode
Channel	Value	Function
9		COLOR MACROS
	73 - 76	MACRO 19
	77 - 80	MACRO 20
	81 - 84	MACRO 21
	85 - 88	MACRO 22
	89 - 92	MACRO 23
	93 - 96	MACRO 24
	97 - 100	MACRO 25
	101 - 104	MACRO 26
	105 - 108	MACRO 27
	109 - 112	MACRO 28
	113 - 116	MACRO 29
	117 - 120	MACRO 30
	121 - 124	MACRO 31
	125 - 128	MACRO 32
	129 - 132	MACRO 33
	133 - 136	MACRO 34
	137 - 140	MACRO 35
	141 - 144	MACRO 36
	145 - 148	MACRO 37
	149 - 152	MACRO 38
	153 - 156	MACRO 39
	157 - 160	MACRO 40
	161 - 164	MACRO 41
	165 - 168	MACRO 42
	169 - 172	MACRO 43
	173 - 176	MACRO 44
	177 - 180	MACRO 45
	181 - 184	MACRO 46
	185 - 188	MACRO 47
	189 - 192	MACRO 48
	193 - 196	MACRO 49
	197 - 200	MACRO 50
	201 - 204	MACRO 51

Inno Color Beam Z7		14 Channel Mode
Channel	Value	Function
9		COLOR MACROS
	205 - 208	MACRO 52
	209 - 212	MACRO 53
	213 - 216	MACRO 54
	217 - 220	MACRO 55
	221 - 224	MACRO 56
	225 - 228	MACRO 57
	229 - 232	MACRO 58
	233 - 236	MACRO 59
	237 - 240	MACRO 60
	241 - 244	MACRO 61
	245 - 248	MACRO 62
	249 - 252	MACRO 63
	253 - 255	MACRO 64
10		SHUTTER/STROBING
	0 - 19	SHUTTER CLOSED
	20 - 24	OPEN
	25 - 64	STROBING FAST - SLOW
	65 - 69	OPEN
	70 - 84	SLOW OPEN - FAST CLOSE
	85 - 89	OPEN
	90 - 104	FAST OPEN - SLOW CLOSE
	105 - 109	OPEN
	110 - 124	RANDOM STROBE
	125 - 129	OPEN
	130 - 144	RANDOM OPENING PULSE
	145 - 149	OPEN
	150 - 164	RANDOM CLOSING PULSE
	165 - 169	OPEN
	170 - 184	BURST PULSE
	185 - 189	OPEN
	190 - 204	RANDOM BURST PULSE
	205 - 209	OPEN
	210 - 224	PULSING

Inno Color Beam Z7		14 Channel Mode
Channel	Value	Function
10		SHUTTER/STROBING
	225 - 229	OPEN
	230 - 244	BURST
	245 - 255	OPEN
11	0 - 255	MASTER DIMMER 0% - 100%
12	0 - 225	ZOOM WIDE - NARROW
13	0 - 225	PAN/TILT MOVEMENT SPEED MAX. - MIN. MOVEMENT SPED
14		RESET
	0 - 9	NO FUNCTION
	10 - 14	RESET ALL
	15 - 255	NO FUNCTION

Inno Color Beam Z7 Photometric Chart

Beam angle 10°	R	7600	1700	917	500	328	(Lux)
	G	19600	5300	2300	1340	830	
	B	690	202	99	61	47	
	W	21800	6100	2680	1490	150	
	RGBW	47500	12700	5000	3200	1950	

Beam angle 60°	R	610	200	87	55	42	(Lux)
	G	1500	430	204	125	86	
	B	73	32	25	21	17	
	W	1680	480	217	132	91	
	RGBW	3680	980	440	265	160	

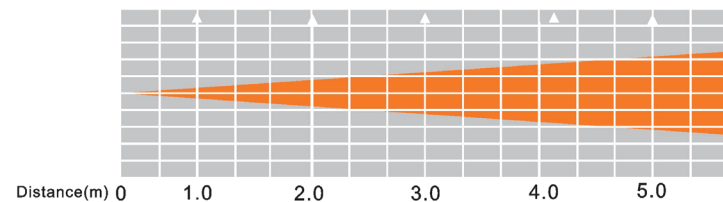

Inno Color Beam Z7 Dimmer Curve Chart

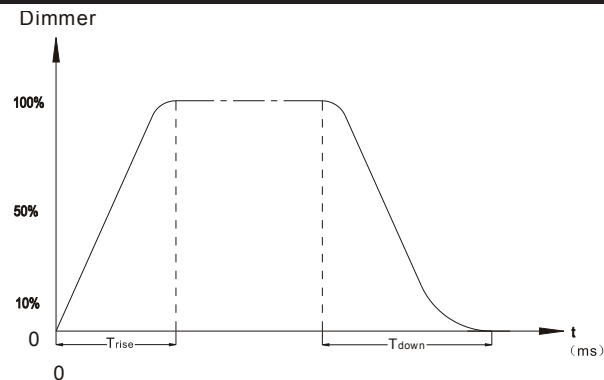

Ramp Effect	0S (Fade Time)		1S (Fade Time)	
	T _{rise} (ms)	T _{down} (ms)	T _{rise} (ms)	T _{down} (ms)
Standard	0	0	0	0
Stage	780	1100	1540	1660
TV	1180	1520	1860	1940
Architectural	1380	1730	2040	2120
Theatre	1580	1940	2230	2280

Inno Color Beam Z7

Fuse Replacement

Locate and remove the unit's power cord. Once the cord has been removed locate the fuse holder located inside the power socket. Insert a flat-head screw driver into the power socket and gently pry out the fuse holder. Remove the bad fuse and replace with a new one. The fuse holder has a built-in socket for a spare fuse be sure not to confuse the spare fuse with active fuse.

Inno Color Beam Z7

Cleaning

Due to fog residue, smoke, and dust cleaning the internal and external optical lenses must be carried out periodically to optimize light output.

1. Use a soft cloth to wipe down the outside casing.

Cleaning frequency depends on the environment in which the fixture operates (i.e. smoke, fog residue, dust, dew).

Inno Color Beam Z7

Troubleshooting

Listed below are a few common problems the user may encounter, with solutions.

Unit not responding to DMX:

1. Check that the DMX cables are connected properly and are wired correctly (pin 3 is "hot"; on some other DMX devices pin 2 may be 'hot'). Also, check that all cables are connected to the right connectors; it does matter which way the inputs and outputs are connected.

Unit does not respond to sound:

1. Quiet or high pitched sounds will not activate the unit.
2. Check the sound sensitivity level.

*If problems are not resolved; Contact ADJ Products, LLC for service.
1-800-322-6337*

Inno Color Beam Z7

Warranty

MANUFACTURER'S LIMITED WARRANTY

- A. ADJ Products, LLC hereby warrants, to the original purchaser, ADJ Products, LLC products to be free of manufacturing defects in material and workmanship for a prescribed period from the date of purchase (see specific warranty period on reverse). This warranty shall be valid only if the product is purchased within the United States of America, including possessions and territories. It is the owner's responsibility to establish the date and place of purchase by acceptable evidence, at the time service is sought.
- B. **For warranty service you must obtain a Return Authorization number (RA#) before sending back the product—please contact ADJ Products, LLC Service Department at 800-322-6337.** Send the product only to the ADJ Products, LLC factory. All shipping charges must be pre-paid. If the requested repairs or service (including parts replacement) are within the terms of this warranty, ADJ Products, LLC will pay return shipping charges only to a designated point within the United States. If the entire instrument is sent, it must be shipped in its original package. No accessories should be shipped with the product. If any accessories are shipped with the product, ADJ Products, LLC shall have no liability whatsoever for loss of or damage to any such accessories, nor for the safe return thereof.
- C. This warranty is void if the serial number has been altered or removed; if the product is modified in any manner which ADJ Products, LLC concludes, after inspection, affects the reliability of the product; if the product has been repaired or serviced by anyone other than the ADJ Products, LLC factory unless prior written authorization was issued to purchaser by ADJ Products, LLC; if the product is damaged because not properly maintained as set forth in the instruction manual.
- D. This is not a service contract, and this warranty does not include maintenance, cleaning or periodic check up. During the period specified above, ADJ Products, LLC will replace defective parts at its expense with new or refurbished parts, and will absorb all expenses for warranty service and repair labor by reason of defects in material or workmanship. The sole responsibility of ADJ Products, LLC under this warranty shall be limited to the repair of the product, or replacement thereof, including parts, at the sole discretion of ADJ Products, LLC. All products covered by this warranty were manufactured after August 15, 2012, and bear identifying marks to that effect.
- E. ADJ Products, LLC reserves the right to make changes in design and/or improvements upon its products without any obligation to include these changes in any products theretofore manufactured.

No warranty, whether expressed or implied, is given or made with respect to any accessory supplied with products described above. Except to the extent prohibited by applicable law, all implied warranties made by ADJ Products, LLC in connection with this product, including warranties of merchantability or fitness, are limited in duration to the warranty period set forth above. And no warranties, whether expressed or implied, including warranties of merchantability or fitness, shall apply to this product after said period has expired. The consumer's and/or Dealer's sole remedy shall be such repair or replacement as is expressly provided above; and under no circumstances shall ADJ Products, LLC be liable for any loss or damage, direct or consequential, arising out of the use of, or inability to use, this product.

This warranty is the only written warranty applicable to ADJ Products, LLC Products and supersedes all prior warranties and written descriptions of warranty terms and conditions heretofore published.

MANUFACTURER'S LIMITED WARRANTY PERIODS:

- **Lighting Products = 1-year (365 days) Limited Warranty** (Such as: Special Effect Lighting, Intelligent Lighting, UV lighting, Strobes, Fog Machines, Bubble Machines, Mirror Balls, Par Cans, Trussing, Lighting Stands etc. excluding LEDs and lamps)
- **Laser Products = 90-Day Limited Warranty**
- **L.E.D. Products = 2-year (730 days) Limited Warranty** (excluding motors, PCB boards, and power supplies, which have a 1-year (365 day Limited Warranty) and batteries which have a 180 day limited warranty).

SPECIFICATIONS:

Voltage:	100V~240V 50Hz/60Hz
LEDs:	7 x 10W Quad LEDs (4-in1)
Power Consumption:	104W
Beam Angle:	10 ~ 60 Degrees
Fuse:	7Amp
Power Cord Daisy Chain:	4 Fixtures Max. (120V) 8 Fixtures Max. (230V)
Weight:	17 lbs./ 7.5Kgs.
Dimensions:	10.5" (L) x 6.75" (W) x 13.5" (H) 262 x 167 x 340mm
Colors:	RGBW Color Mixing
DMX Channels:	14 DMX Channels
Working Position:	Any safe working position
Warranty:	2 Year (730 days)

Auto Sensing Voltage: *This fixture contains a automatic voltage switch, which will auto sense the voltage when it is plugged into the power source.*

Please Note: Specifications and improvements in the design of this unit and this manual are subject to change without any prior written notice.

ADJ Products, LLC
6122 S. Eastern Ave. Los Angeles, CA 90040 USA
Tel: 323-582-2650 / Fax: 323-725-6100
Web: www.adj.com / E-mail: info@americandj.com

A.D.J. Supply Europe B.V.
Junostraat 2
6468 EW Kerkrade
Netherlands

Follow Us On:



facebook.com/americandj
twitter.com/americandj
youtube.com/adjlighting

service@adjgroup.eu / www.adj.eu
Tel: +31 45 546 85 00 / Fax: +31 45 546 85 99