

AVANTE

Imperio Pro IMP118

ELEVATING
YOUR
SOUND

USER
MANUAL

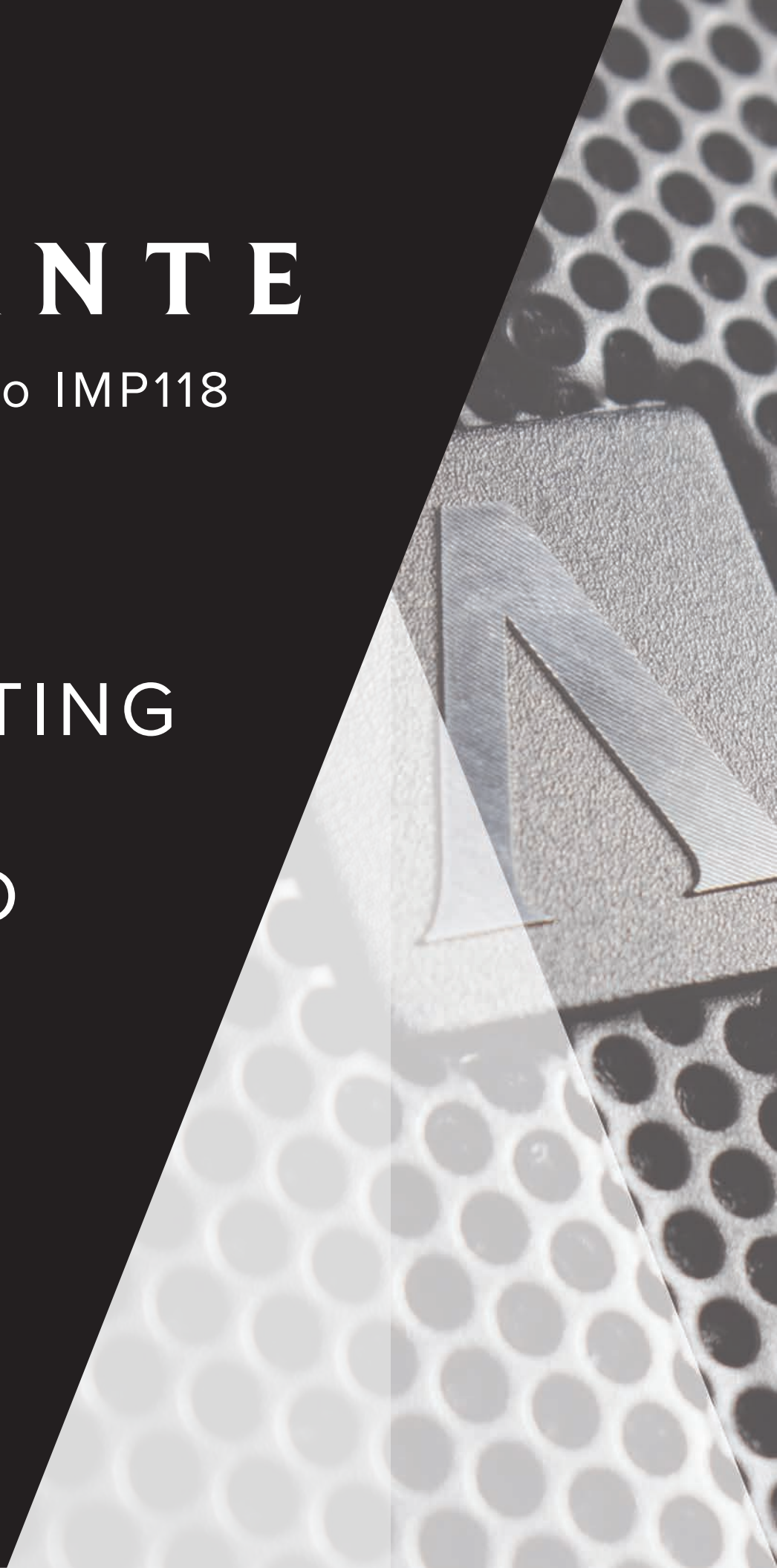

©2023 Avante Audio all rights reserved. Information, specifications, diagrams, images, and instructions herein are subject to change without notice. Avante logo and identifying product names and numbers herein are trademarks of Avante Audio. Copyright protection claimed includes all forms and matters of copyrightable materials and information now allowed by statutory or judicial law or hereinafter granted. Product names used in this document may be trademarks or registered trademarks of their respective companies and are hereby acknowledged. All non-Avante brands and product names are trademarks or registered trademarks of their respective companies.

Avante Audio and all affiliated companies hereby disclaim any and all liabilities for property, equipment, building, and electrical damages, injuries to any persons, and direct or indirect economic loss associated with the use or reliance of any information contained within this document, and/or as a result of the improper, unsafe, insufficient and negligent assembly, installation, rigging, and operation of this product.

The Bluetooth® word mark and logos are registered trademarks owned by Bluetooth SIG, Inc. and any use of such marks by Avante Audio is under license. Other trademarks and trade names are those of their respective owners.

AVANTE World Headquarters USA

6122 S. Eastern Ave. | Los Angeles, CA 90040 USA
323-316-9722 | Fax: 323-582-2941 | www.avanteaudio.com | info@avanteaudio.com

AVANTE NETHERLANDS

Junostraat 2 | 6468 EW Kerkrade | Netherlands
+31 45 546 85 00 | Fax: +31 45 546 85 99 | europa@avanteaudio.com

AVANTE MEXICO

Santa Ana 30 | Parque Industrial Lerma | Lerma Mexico 52000
+52 (728) 282.7070 | ventas@avanteaudio.com

FCC STATEMENT

This device complies with Part 15 of the FCC Rules. Operation is subject to the following two conditions: (1) this device may not cause harmful interference, and (2) this device must accept any interference received, including interference that may cause undesired operation.

FCC RADIO FREQUENCY INTERFERENCE WARNINGS & INSTRUCTIONS

This product has been tested and found to comply with the limits as per Part 15 of the FCC Rules. These limits are designed to provide reasonable protection against harmful interference in a residential installation. This device uses and can radiate radio frequency energy and, if not installed and used in accordance with the included instructions, may cause harmful interference to radio communications. However, there is no guarantee that interference will not occur in a particular installation. If this device does cause harmful interference to radio or television reception, which can be determined by turning the device off and on, the user is encouraged to try to correct the interference by one or more of the following methods:

- Reorient or relocate the device.
- Increase the separation between the device and the receiver.
- Connect the device to an electrical outlet on a circuit different from which the radio receiver is connected.
- Consult the dealer or an experienced radio/TV technician for help.

Energy Saving Matters (EuP 2009/125/EC)

Saving electric energy is a key to help protecting the environment. Please turn off all electrical products when they are not in use. To avoid power consumption in idle mode, disconnect all electrical equipment from power when not in use. Thank you!

Document Version: An updated version of this document may be available online. Please check online at www.avante.com for the latest revision/update of this document before beginning installation and use.

Date	Document Version	Notes
12/08/2023	1.0	Initial release

CONTENTS

General Information	4
Limited Warranty (USA Only)	5
Safety Guidelines	6
Overview	8
Installation	9
Operation	14
Application Diagrams	17
Frequency Charts	18
Specifications	19
Dimensional Drawings	20
Components & Accessories FCC Statement	21

GENERAL INFORMATION

INTRODUCTION

This speaker is designed for professional use only. Please read and understand all the instructions and guidelines in this manual carefully and thoroughly before attempting to operate these speakers. These instructions contain important information regarding safety, installation, and use.

UNPACKING

Every speaker has been thoroughly tested and has been shipped in perfect operating condition. Carefully check the shipping carton for damage that may have occurred during shipping. If the carton appears to have been damaged, carefully inspect the speaker for damage and be sure all accessories necessary to install and operate the speaker have arrived intact. In the event that damage has been found or parts are missing, please contact our customer support team for further instructions. Please do not return this speaker to your dealer without first contacting customer support at the number listed below. Please do not discard the shipping carton in the trash. Please recycle whenever possible.

CUSTOMER SUPPORT

AVANTE provides a customer support line to provide set up help, assist with any questions or problems that may arise during set up or initial installation, and for any service related issues. You may also visit us on the web at www.avanteaudio.com for any comments or suggestions.

AVANTE SERVICE USA – Monday – Friday 8:00am to 4:30pm PST

Voice: 800-322-6337

Fax: 323-532-2941

support@avanteaudio.com

AVANTE SERVICE EUROPE - Monday - Friday 08:30 to 17:00 CET

Voice: +31 45 546 85 30

Fax: +31 45 546 85 96

europe@avanteaudio.com



@avanteaudio

WARRANTY REGISTRATION

Please register your product online: www.avanteaudio.com. Online product registration is required in order to activate the third year of the 3-year warranty. All returned service items, whether under warranty or not, must be freight pre-paid and accompanied by a return authorization (R.A.) number. The R.A. number must be clearly written on the outside of the return package. A brief description of the problem as well as the R.A. number must also be written down on a piece of paper and included in the shipping container. If the unit is under warranty, you must provide a copy of your proof of purchase invoice, and the unit must be registered online at www.avanteaudio.com to receive year 3 of the 3-year warranty. Items returned without an R.A. number clearly marked on the outside of the package will be refused and returned at customer's expense. You may obtain an R.A. number by contacting customer support.

LIMITED WARRANTY (USA ONLY)

1. ADJ Products, LLC hereby warrants, to the original purchaser, AVANTE products to be free of manufacturing defects in material and workmanship for a prescribed period of up to 3-years (1,095 days) from the original purchase date. Product must be registered online at www.avanteaudio.com in order to activate year 3 of the 3-year warranty period. This warranty shall be valid only if the product is purchased within the United States of America, including possessions and territories. It is the owner's responsibility to establish the date and place of purchase by acceptable evidence at the time service is sought.
2. For warranty service you must obtain a Return Authorization number (RA#) before sending the product back; please contact ADJ Products, LLC Service Department at 800-322-6337. Send the product only to the ADJ Products, LLC factory. All shipping charges must be pre-paid. If the requested repairs or service (including parts replacement) are within the terms of this warranty, ADJ Products, LLC will pay return shipping charges only to a designated point within the United States. If the entire instrument is sent, it must be shipped in its original package. No accessories should be shipped with the product. If any accessories are shipped with the product, ADJ Products, LLC shall incur no liability whatsoever for loss of or damage to any such accessories, or for the safe return thereof.
3. This warranty is void if the serial number has been altered or removed; if the product is modified in any manner which ADJ Products, LLC concludes, after inspection, affects the reliability of the product; if the product has been repaired or serviced by anyone other than the ADJ Products, LLC factory unless prior written authorization was issued to purchaser by ADJ Products, LLC; if the product is damaged because it was not properly maintained as set forth in the instruction manual.
4. This is not a service contract, and this warranty does not include maintenance, cleaning or periodic checkup. During the period specified above, ADJ Products, LLC will replace defective parts at its expense with new or refurbished parts, and will absorb all expenses for warranty service and repair labor by reason of defects in material or workmanship. The sole responsibility of ADJ Products, LLC under this warranty shall be limited to the repair of the product, or replacement thereof, including parts, at the sole discretion of ADJ Products, LLC. All products covered by this warranty were manufactured after August 15, 2012, and bear identifying marks to that effect.
5. ADJ Products, LLC reserves the right to make changes in design and/or improvements upon its products without any obligation to include these changes in any products theretofore manufactured. No warranty, whether expressed or implied, is given or made with respect to any accessory supplied with products described above. Except to the extent prohibited by applicable law, all implied warranties made by ADJ Products, LLC in connection with this product, including warranties of merchantability or fitness, are limited in duration to the warranty period set forth above. And no warranties, whether expressed or implied, including warranties of merchantability or fitness, shall apply to this product after said period has expired. The consumer's and/or Dealer's sole remedy shall be such repair or replacement as is expressly provided above; and under no circumstances shall ADJ Products, LLC be liable for any loss or damage, direct or consequential, arising out of the use of, or inability to use, this product. This warranty is the only written warranty applicable to ADJ Products, LLC Products and supersedes all prior warranties and written descriptions of warranty terms and conditions heretofore published.
6. Warranty Registration: Please register your product online: www.avanteaudio.com. Online product registration is required in order to activate the third year of the 3-year warranty. All returned service items, whether under warranty or not, must be freight pre-paid and accompany a return authorization (R.A.) number. The R.A. number must be clearly written on the outside of the return package. A brief description of the problem as well as the R.A. number must also be written down on a piece of paper and included in the shipping container. If the unit is under warranty, you must provide a copy of your proof of purchase invoice and the unit must be registered online at www.avanteaudio.com to receive year 3 of the 3-year warranty. Items returned without an R.A. number clearly marked on the outside of the package will be refused and returned at customer's expense. You may obtain an R.A. number by contacting customer support.

SAFETY GUIDELINES

This speaker is a sophisticated piece of electronic equipment. To guarantee a smooth operation, it is important to follow all instructions and guidelines in this manual. AVANTE is not responsible for injury and/or damages resulting from the misuse of this speaker due to the disregard of the information printed in this manual. Only qualified and/or certified personnel should perform the installation of this speaker and all included and/or optional rigging accessories. Only the original included and/or optional rigging parts and accessories for this speaker should be used for proper installation. Any modifications to the speaker, included and/or optional rigging parts and accessories will void the original manufacturer's warranty and increase the risk of damage and/or personal injury.



PROTECTION CLASS 1 – SPEAKER MUST BE PROPERLY GROUNDED

TO REDUCE RISK OF ELECTRICAL SHOCK, DO NOT REMOVE ANY COVER. THERE ARE NO USER SERVICEABLE PARTS INSIDE THIS SPEAKER. DO NOT ATTEMPT ANY REPAIRS YOURSELF, AS DOING SO WILL VOID YOUR MANUFACTURER'S WARRANTY. DAMAGES RESULTING FROM MODIFICATIONS TO THIS SPEAKER AND/OR THE DISREGARD OF SAFETY INSTRUCTIONS AND GUIDELINES IN THIS MANUAL VOID THE MANUFACTURER'S WARRANTY AND ARE NOT SUBJECT TO ANY WARRANTY CLAIMS AND/OR REPAIRS. NEVER OPEN THIS SPEAKER WHILE IN USE! UNPLUG POWER BEFORE SERVICING SPEAKER! KEEP FLAMMABLE MATERIALS AWAY FROM SPEAKER!



**DRY LOCATIONS USE ONLY!
DO NOT EXPOSE SPEAKER TO RAIN AND/OR MOISTURE!
DO NOT SPILL WATER AND/OR LIQUIDS ON OR INTO THE SPEAKER!**

This speaker is for PROFESSIONAL USE ONLY! Read all INSTRUCTIONS and follow all WARNINGS!

- **DO NOT** use speaker near wet and/or damp locations. Speaker must be kept away from direct contact with liquids and must not be exposed to water/liquid dripping or splashing.
- **DO NOT** attempt installation and/or operation without knowledge how to do so. Consult a professional sound equipment installer for proper and safe speaker installation. ONLY the original included, and/or optional rigging parts and accessories listed in this manual should be used for installation and operation.
- **DO NOT** expose any part of the speaker to open flame or smoke, or position speaker close to any flammable materials during operation. The speaker contains an internal power amplifier that produces heat during use. Keep speaker away from heat sources such as radiators, heat registers, stoves, or other appliances (including amplifiers) that produce heat.
- Be sure to install this speaker in an area that will allow proper ventilation. Allow approximately 6 inches (152mm) behind the speaker cabinet for proper cooling.
- **DO NOT** operate speaker if power cord is frayed, crimped, damaged, and/or if any of the power cord connectors are damaged and do not insert into the speaker securely with ease. NEVER force a power cord connector into the speaker. If the power cord or any of its connectors are damaged, replace it immediately with a new one of the same power rating.
- **DO NOT** disassemble speaker, as there are NO user serviceable parts inside. Refer all servicing to qualified service personnel. Servicing is required when the speaker has been damaged in any way, such as damage to the power-supply cord or plug, exposure to liquid, rain, or moisture, objects falling onto the speaker or dropping of the speaker itself, or any abnormal operation.
- **DO NOT** defeat the safety purpose of the polarized or grounding-type plug. A polarized plug has two blades with one wider than the other. A grounding type plug has two blades and a third grounding prong. The wide blade or the third prong is provided for your safety. If the provided plug does not fit into your outlet, consult an electrician for replacement of the obsolete outlet.

SAFETY GUIDELINES

- **POWER SOURCES:** This product must be connected to a power supply only of the type described in these operating instructions, or as marked on the unit. This product is Country Specific.
- **PROTECTIVE EARTHING TERMINAL:** The speaker should be connected to a mains socket outlet with a protective earth-ground/earthing connection.
- **ONLY** handle power cord by the plug end, and never pull the plug out by tugging the wire portion of the cord.
- **DO NOT** use solvents or glass cleaner to clean speaker. Clean only with a dry cloth.
- **ALWAYS** disconnect speaker from main power source before performing any servicing or cleaning procedure.
- **CAUTION:** To avoid physical damage, read the installation instructions carefully before installation.
- **CAUTION:** Listening to speakers at high volume for extended time or within immediate proximity may damage hearing.
- **CAUTION:** Speakers should be installed/operated by qualified and trained professionals ONLY.
- **CAUTION:** Always mount speakers in a safe and stable manner.
- **CAUTION:** Wear appropriate safety equipment during speaker installation.
- **CAUTION:** Route power and audio cables so that they are NOT likely to be walked on or pinched.
- **CAUTION:** Unplug the speaker during lightning storms and/or when unused for long periods of time.
- **ONLY** use the original packaging materials and/or case to transport the speaker in for service.
- **PLEASE** recycle shipping boxes and packaging whenever possible.



OVERVIEW

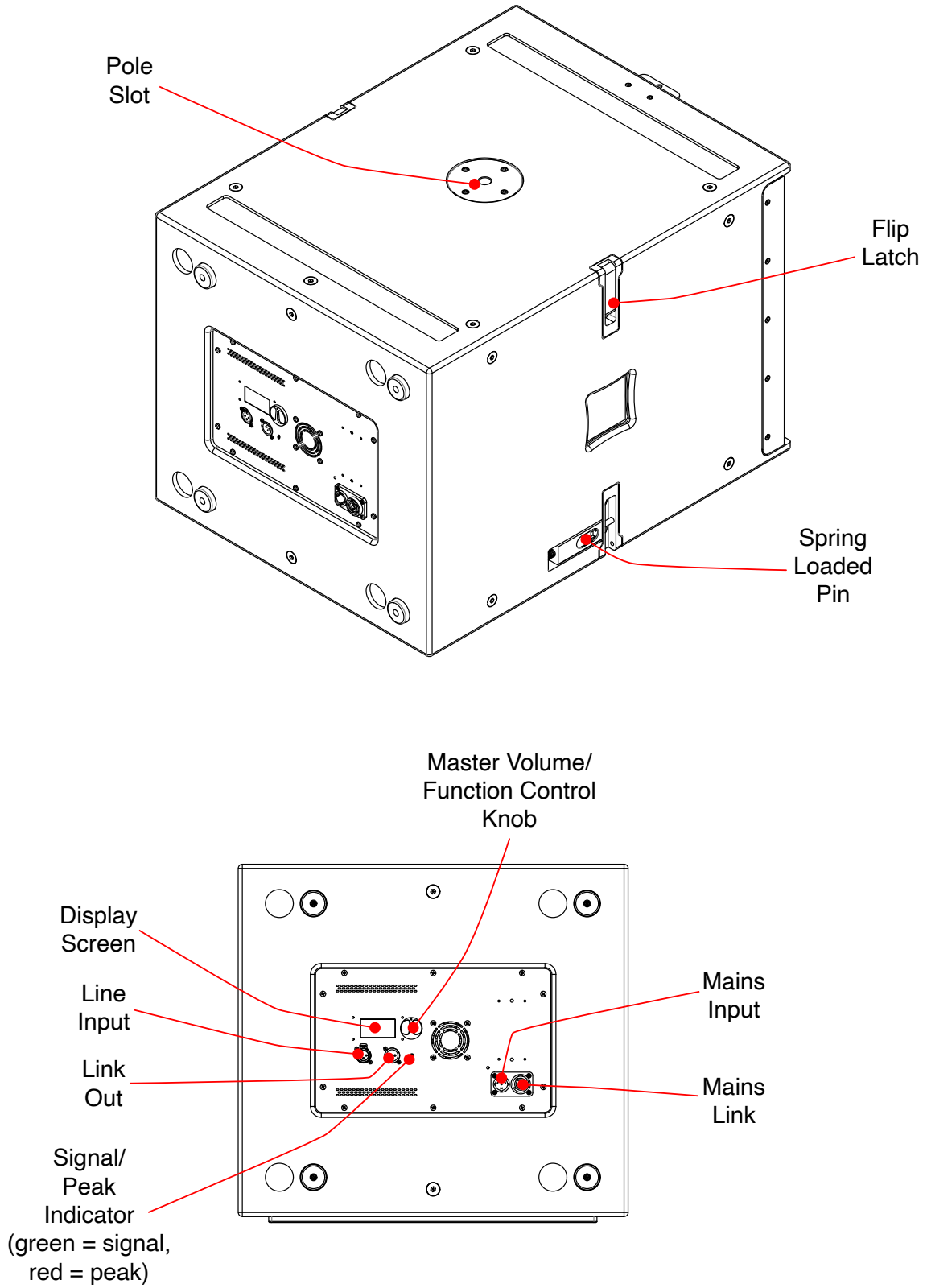

INSTALLATION



FLAMMABLE MATERIAL WARNING

Keep device well away from any flammable materials, decorations, pyrotechnics, etc.



ELECTRICAL CONNECTIONS

A qualified electrician should be used for all electrical connections and/or installations.



DUE TO THE WEIGHT OF THE UNIT (101 LBS / 45.8 KG), LIFTING SHOULD BE DONE BY A TEAM OF AT LEAST TWO PEOPLE IN ORDER TO AVOID INJURY.

DO NOT INSTALL THE DEVICE IF YOU ARE NOT QUALIFIED TO DO SO! ALL INSTALLATIONS MUST BE PERFORMED BY QUALIFIED PROFESSIONAL EQUIPMENT INSTALLERS!

Device **MUST** be installed following all local, national, and country commercial electrical and construction codes and regulations. Before rigging/mounting the device or placing the device on any surface, a professional equipment installer **MUST** be consulted to determine if the mounting point or surface is properly certified to safely hold the combined weight of the device, clamps, cables, and accessories.

Device should be installed away from walking paths, seating areas, or areas where unauthorized personnel might reach the fixture by hand.

NEVER stand directly below the device when installing, removing, or servicing.

INSTALLATION

Flying Installation

For permanent flying installations, use the designated threaded fly points on the top (x5), bottom (x5), left (x4), right (x4), and back (x2) of the device, as shown in the diagram below. Remove the covers from the fly points that you wish to use, then insert optional M10 Eye Bolts into the fly points. Refer to the **Component & Accessories** section of this manual for ordering information for the Eye Bolts.

Please note that fly points are provided for applications that require overhead installation. Safety first! Installation of any equipment in an overhead location should be performed by experienced rigging professionals only.

CAUTION! DO NOT OVER-TIGHTEN EYE BOLTS!

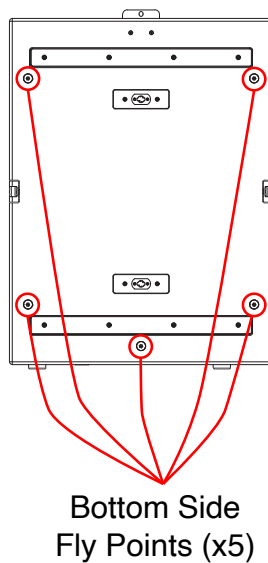
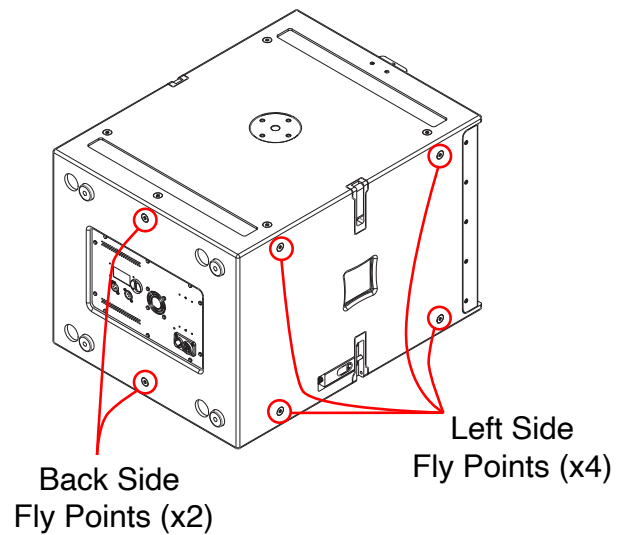
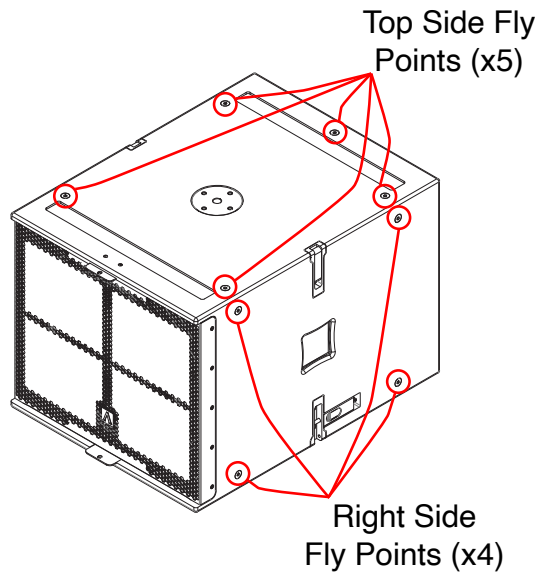

M10 Eye Bolt for
Insertion into Fly Points



INSTALLATION

Normal / Cardioid Stacking

These subwoofers are designed for easy vertical stacking. To do so, simply stack the units such that the two grooves on the top of one unit align with the stand strips on the bottom of the unit above. ***DUE TO THE WEIGHT OF THE UNIT (101 LBS / 45.8 KG), LIFTING SHOULD BE DONE BY A TEAM OF AT LEAST TWO PEOPLE IN ORDER TO AVOID INJURY.*** Press in the spring pin of the top unit, then flip the latch of the lower unit into place so that the hole in the latch aligns with the spring pin. Release the spring pin to secure the upper unit in place, then repeat with the latch and pin on the other side of the units.

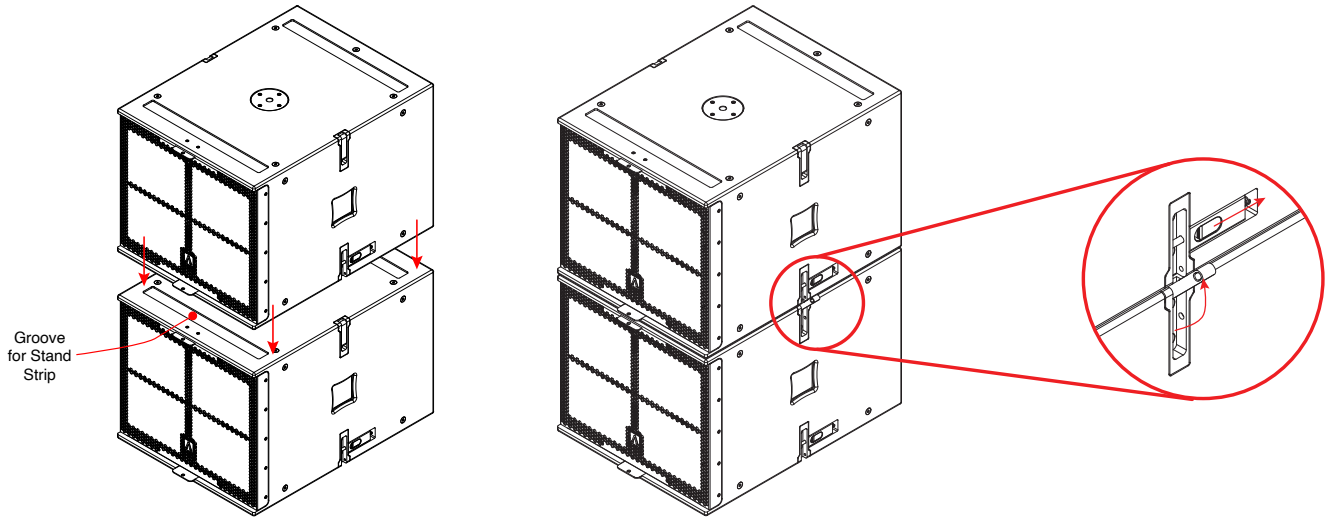

Additionally, the units may be stacked facing in opposite directions in a cardioid configuration, as shown below.

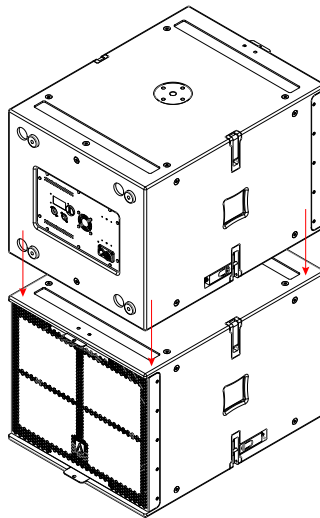

INSTALLATION

Caster Board

These subwoofers can also be fitted with Avante Audio's IMC118 caster boards (sold separately) in either horizontal or vertical (for storage/transport only) orientation. ***DUE TO THE WEIGHT OF THE UNIT (101 LBS / 45.8 KG), LIFTING SHOULD BE DONE BY A TEAM OF AT LEAST TWO PEOPLE IN ORDER TO AVOID INJURY. ALWAYS ENGAGE CASTER LOCKS BEFORE PLACING SPEAKERS ON THE BOARD.***

For vertical orientation, place the unit on the ground with the speaker grill facing upwards. Gently place the caster board atop the speaker grill frame with the wheels pointing upwards. Locate the two mounting tabs on the speaker grill frame (the lower tab is located just below the Avante logo, while the upper tab is located at the opposite edge of the speaker grill), then depress the two spring pins on the caster board and align the spring pins with the mounting tabs on the speaker grill frame. Release the spring pins to secure the caster board to the subwoofer. Please note that this configuration is for storage or transport only.

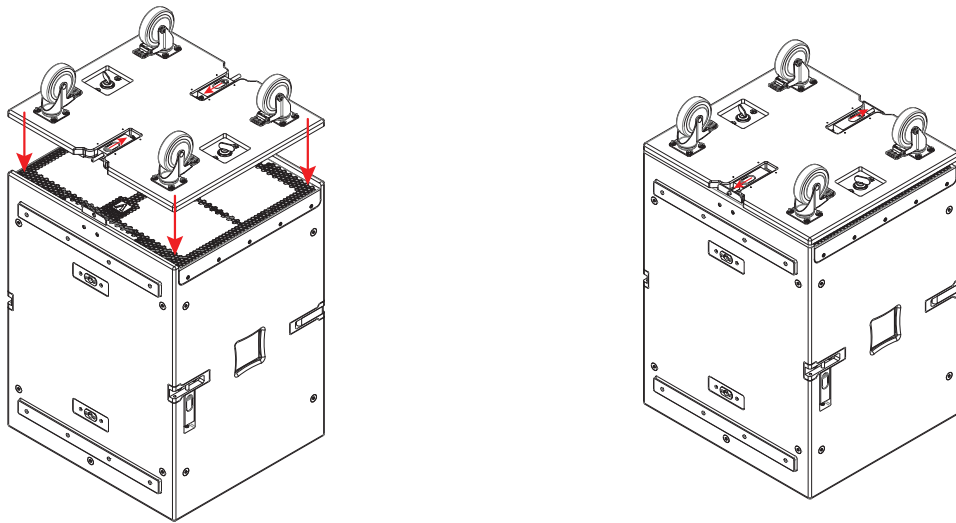

For horizontal orientation, place the unit on the ground with the stands facing upwards. Align the two twist lock fasteners on the caster board with the matching holes on the subwoofer, then twist the fasteners to secure the caster board to the subwoofer. The caster board should fit securely between the stands.

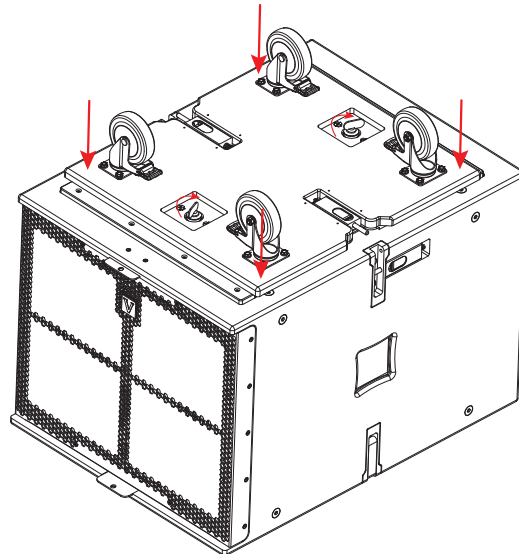

INSTALLATION

Vertical Stacking

These units can be stacked vertically on top of a caster board for easy transport or moving. To do so, begin by engaging the caster locks on the board. Stand the first unit vertically and attach the caster board to the speaker grille frame, as shown in the **Installation - Caster Board** section of this manual, and secure in place using the spring pins on the caster board. Flip the first unit so that the control panel is facing upwards, then stack a second unit on top with the control panel facing downward. ***DUE TO THE WEIGHT OF THE UNIT (101 LBS / 45.8 KG), LIFTING SHOULD BE DONE BY A TEAM OF AT LEAST TWO PEOPLE IN ORDER TO AVOID INJURY.*** The control panels of the two units should be facing each other, allowing the small circular stands and slots surrounding the control panels of the two units to interlock with each other.

Please note that this configuration is for storage and transport only.

Please exercise caution when moving units in this configuration, as the two subwoofer units are NOT fixed together!

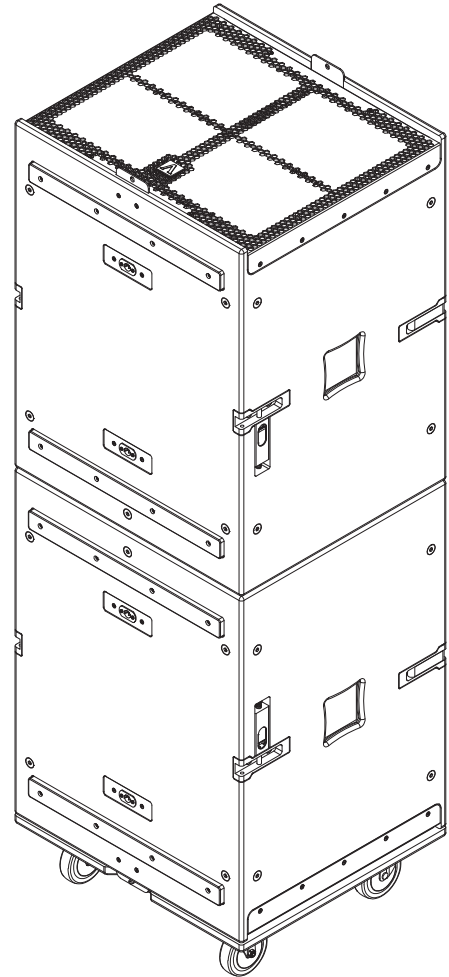
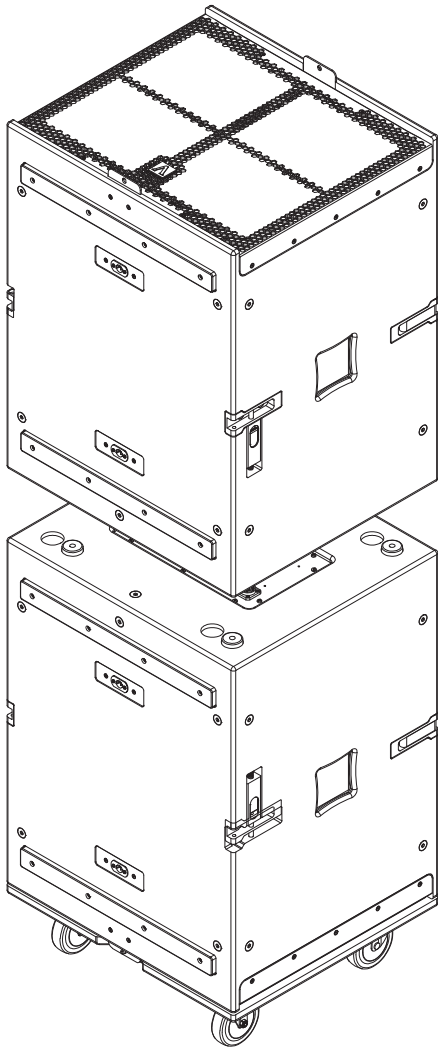

OPERATION

1. Press the function control knob to access the system menu.
2. Rotate the function control knob to scroll through the menu options.
3. Press the function control knob to select the desired menu option.
4. Rotate the function control knob to adjust the settings of the selected menu option.
5. Press the function control knob to confirm your choice and return to the menu.

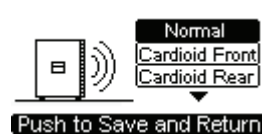
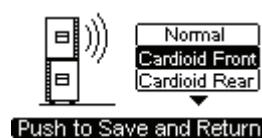
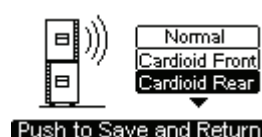
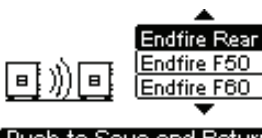
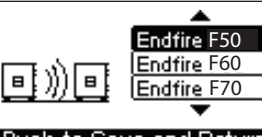
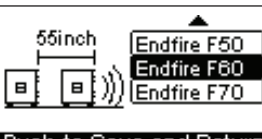
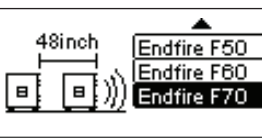
MENU OPTION	LEVEL 1		LEVEL 2	DESCRIPTION				
MAIN	<table border="1"> <tr> <td></td> <td>150Hz</td> </tr> <tr> <td>NORMAL</td> <td>NONE</td> </tr> </table> <p>IMP 118</p> <p>_____MUTE</p>		150Hz	NORMAL	NONE			Main menu screen
	150Hz							
NORMAL	NONE							
MODE	<table border="1"> <tr> <td></td> <td>150Hz</td> </tr> <tr> <td>NORMAL</td> <td>NONE</td> </tr> </table> <p>IMP 118</p> <p>←OST MODE POLARITY X-C→</p>		150Hz	NORMAL	NONE	-->		Normal mode
			150Hz					
		NORMAL	NONE					
			Cardioid front mode					
			Cardioid rear mode					
			Endfire rear mode					
			Endfire F50 mode					
	Endfire F60 mode							
	Endfire F70 mode							

OPERATION

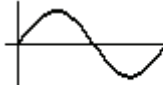
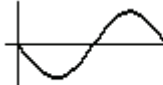
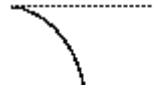
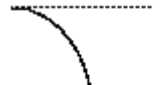
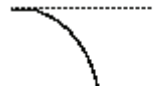
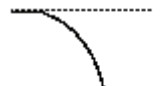
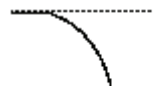
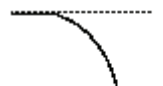
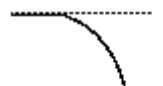
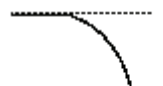
MENU OPTION	LEVEL 1		LEVEL 2	DESCRIPTION				
POLARITY	<table border="1" data-bbox="435 275 695 331"> <tr> <td></td> <td>150Hz</td> </tr> <tr> <td>NORMAL</td> <td>NONE</td> </tr> </table> <p data-bbox="483 338 634 373">IMP 118</p> <p data-bbox="435 380 695 405">◀MODE POLARITY X-0▶</p>		150Hz	NORMAL	NONE	-->	 <p data-bbox="1003 220 1096 268">Normal Reverse</p> <p data-bbox="836 300 1096 325">Push to Save and Return</p>	Normal polarity
			150Hz					
NORMAL	NONE							
 <p data-bbox="1003 380 1096 428">Normal Reverse</p> <p data-bbox="836 459 1096 485">Push to Save and Return</p>	Reverse polarity							
X-OVER	<table border="1" data-bbox="435 1079 695 1136"> <tr> <td></td> <td>150Hz</td> </tr> <tr> <td>NORMAL</td> <td>NONE</td> </tr> </table> <p data-bbox="483 1142 634 1178">IMP 118</p> <p data-bbox="435 1184 695 1209">◀POLARITY X-OVER DELA▶</p>		150Hz	NORMAL	NONE	-->	 <p data-bbox="1003 562 1096 590">60Hz</p> <p data-bbox="836 621 1096 646">Push to Save and Return</p>	Crossover 60 Hz
			150Hz					
		NORMAL	NONE					
		 <p data-bbox="1003 722 1096 749">70Hz</p> <p data-bbox="836 781 1096 806">Push to Save and Return</p>	Crossover 70 Hz					
		 <p data-bbox="1003 882 1096 909">80Hz</p> <p data-bbox="836 940 1096 966">Push to Save and Return</p>	Crossover 80 Hz					
		 <p data-bbox="1003 1041 1096 1068">90Hz</p> <p data-bbox="836 1100 1096 1125">Push to Save and Return</p>	Crossover 90 Hz					
		 <p data-bbox="1003 1201 1096 1228">100Hz</p> <p data-bbox="836 1264 1096 1289">Push to Save and Return</p>	Crossover 100 Hz					
		 <p data-bbox="1003 1360 1096 1388">110Hz</p> <p data-bbox="836 1423 1096 1449">Push to Save and Return</p>	Crossover 110 Hz					
 <p data-bbox="1003 1520 1096 1547">120Hz</p> <p data-bbox="836 1579 1096 1604">Push to Save and Return</p>	Crossover 120 Hz							
 <p data-bbox="1003 1680 1096 1707">130Hz</p> <p data-bbox="836 1738 1096 1764">Push to Save and Return</p>	Crossover 130 Hz							

OPERATION

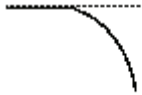
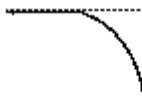
MENU OPTION	LEVEL 1		LEVEL 2	DESCRIPTION								
X-OVER <i>(continued)</i>	<table border="1"> <tr><td></td><td>150Hz</td></tr> <tr><td>NORMAL</td><td>NONE</td></tr> </table> <p>IMP 118 ◀CLARITY X-OVER DELA▶</p>		150Hz	NORMAL	NONE	-->	 <p>140Hz Push to Save and Return</p>	Crossover 140 Hz				
			150Hz									
NORMAL	NONE											
 <p>150Hz Push to Save and Return</p>	Crossover 150 Hz											
DELAY	<table border="1"> <tr><td></td><td>150Hz</td></tr> <tr><td>NORMAL</td><td>NONE</td></tr> </table> <p>IMP 118 ◀V X-OVER DELAY FROM▶</p>		150Hz	NORMAL	NONE	-->	<p>◀101.00▶ ms 1.00 meter 1.00 feet Push to Save and Return</p>	Adjust system delay				
	150Hz											
NORMAL	NONE											
DISPLAY DIM	<table border="1"> <tr><td></td><td>150Hz</td></tr> <tr><td>NORMAL</td><td>NONE</td></tr> </table> <p>IMP 118 ◀LAY DISPLAY DIM▶</p>		150Hz	NORMAL	NONE	-->	<p>Display dims after 10 seconds <input type="checkbox"/> Off <input type="checkbox"/> On Push to Save and Return</p>	Display screen never dims				
			150Hz									
NORMAL	NONE											
<p>Display dims after 10 seconds <input type="checkbox"/> Off <input checked="" type="checkbox"/> On Push to Save and Return</p>	Display screen dims after 10s of inactivity											
RESET	<table border="1"> <tr><td></td><td>150Hz</td></tr> <tr><td>NORMAL</td><td>NONE</td></tr> </table> <p>IMP 118 ◀DISPLAY DIM RESET VO▶</p>		150Hz	NORMAL	NONE	-->	<p>Reset to default settings. Are you sure? <input type="checkbox"/> Yes <input checked="" type="checkbox"/> No Push to Save and Return</p>	Returns to menu without changing system settings				
			150Hz									
NORMAL	NONE											
<p>Reset to default settings. Are you sure? <input type="checkbox"/> Yes <input checked="" type="checkbox"/> No Push to Save and Return</p>	Restores all settings to factory defaults											
VOLUME	<table border="1"> <tr><td></td><td>150Hz</td></tr> <tr><td>NORMAL</td><td>NONE</td></tr> </table> <p>IMP 118 ◀DIM RESET VOLUME▶</p>		150Hz	NORMAL	NONE	-->	<table border="1"> <tr><td></td><td>150Hz</td></tr> <tr><td>NORMAL</td><td>NONE</td></tr> </table> <p>IMP 118 MUTE</p>		150Hz	NORMAL	NONE	Adjust system volume
	150Hz											
NORMAL	NONE											
	150Hz											
NORMAL	NONE											

APPLICATION DIAGRAMS

Single Unit Input

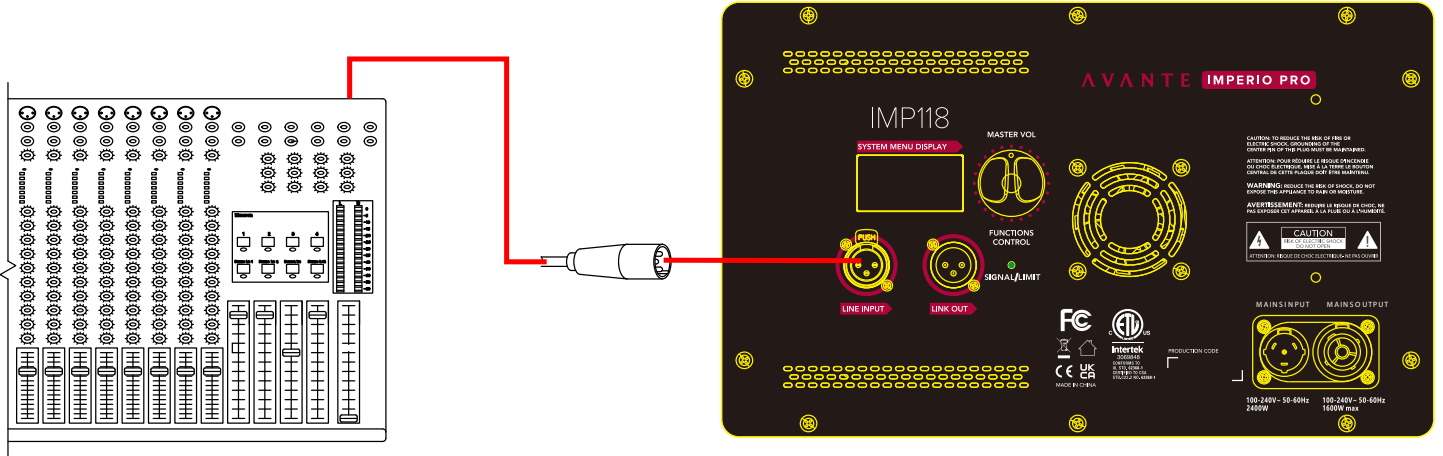

Multiple Daisy-Chain Units

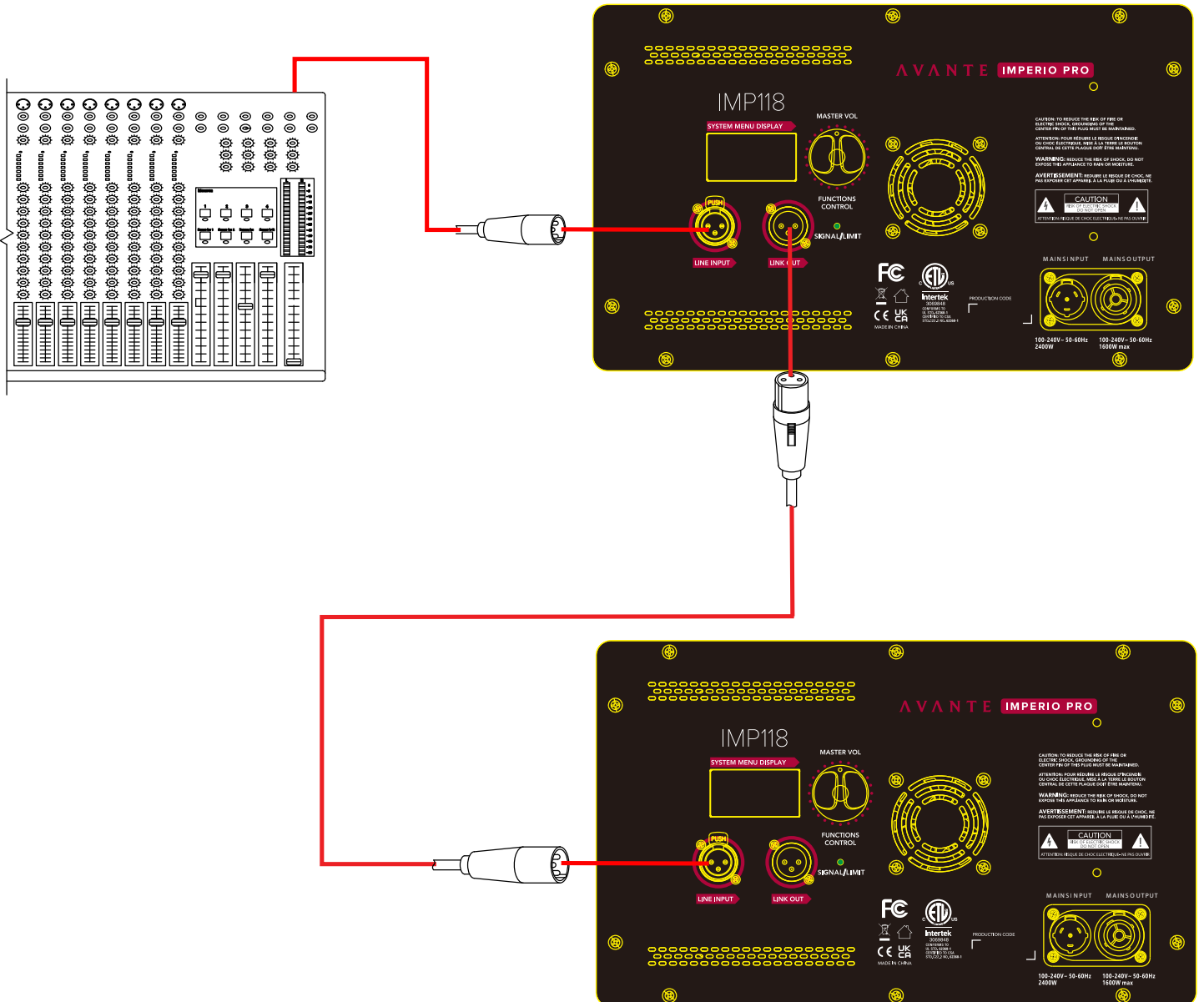

FREQUENCY CHARTS

IMPERIO PRO IMP118 - SPL VS. FREQ CHART, 100 Hz

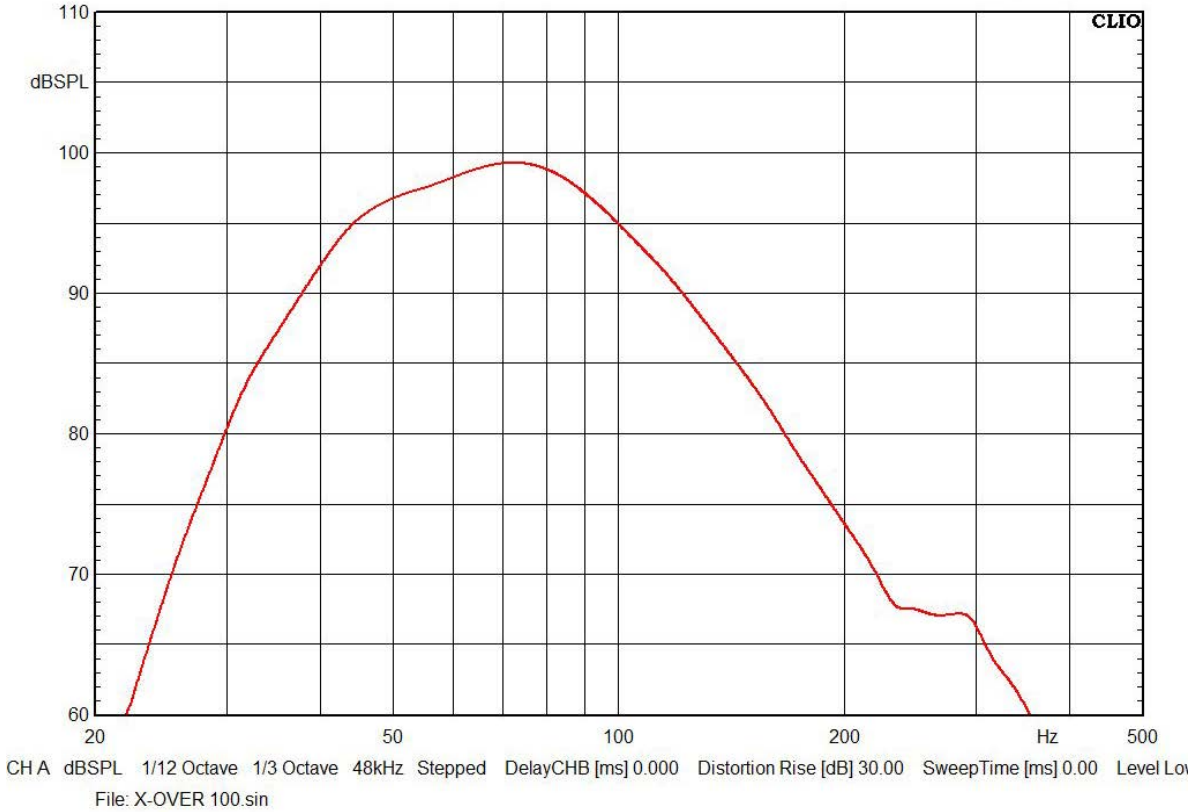

IMPERIO PRO IMP118 - SPL VS. FREQ CHART, 60 Hz / 100 Hz / 150Hz

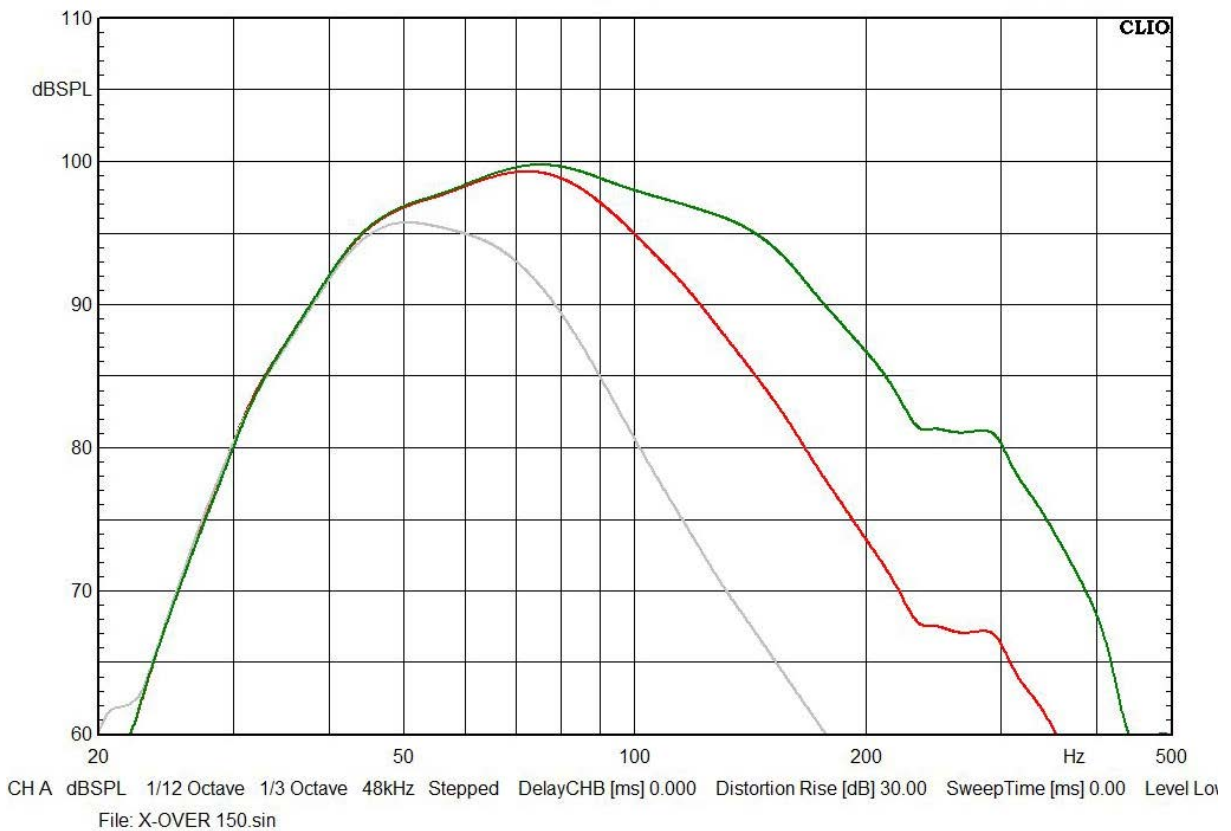

KEY: Gray = 60 Hz, Red = 100 Hz, Green = 150 Hz

SPECIFICATIONS

- System Type: Active DSP Controlled 18-inch Sub, Bass-Reflex, Touring Subwoofer
- Frequency Response: 32 Hz-130 Hz (-10dB) 38 Hz-130 (-3 dB)
- Component: 18-inch High-power. Voice Coil 4-Inch (100mm)
- Coverage pattern: Selectable cardioid and end-fire settings.
- Crossover Frequency: Selectable: 60 Hz, 70, Hz, 80 Hz, 90 Hz, 100 Hz, 120 Hz. Slope- LR 24dB per octave
- Power: Active class-D amplifier- 3600-watts Peak
- Input Gain: Variable
- Maximum SPL: 136 dB Peak
- Enclosure: Premium Birch plywood
- Suspension/Mounting: 20 captiv- nut fly points (M10), Pole Mount (M20)
- Transport: 2 recessed handles, bottom nylon skids, rear rubber feet, interlocking stacking hardware
- Finish: Black Polyuera
- Grill: Black powder-coated steel
- Connectors: Signal In/Thru: XLRf/ XLRm
- AC IN/OUT: IP rated locking connector In/Thru. 100~240VAC 50/60Hz
- Dimensions: 20.75" H x 22.6" W x 29 x 30" D / (527mm H x 574mm W x 762mm D)
- Net Weight: 101 LBS. (45.8 KG)
- Approvals: CE, FCC, UKCA, CETLus (Control #3069848)
- Accessories: Imperio Pro IMC118 interlocking caster board, protective cover and speaker pole



DIMENSIONAL DRAWINGS

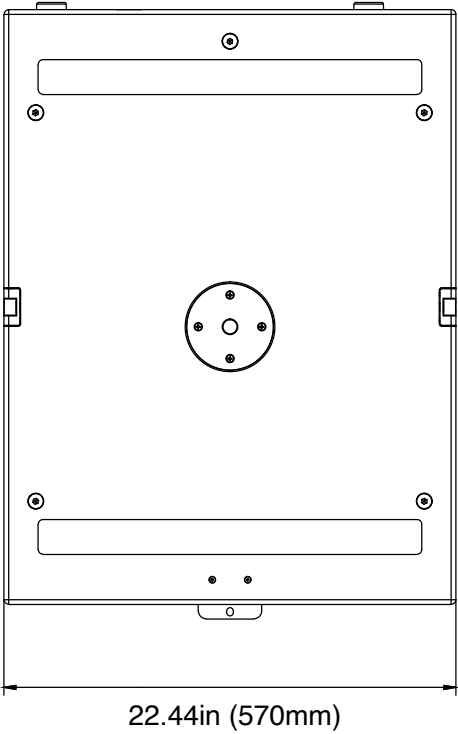
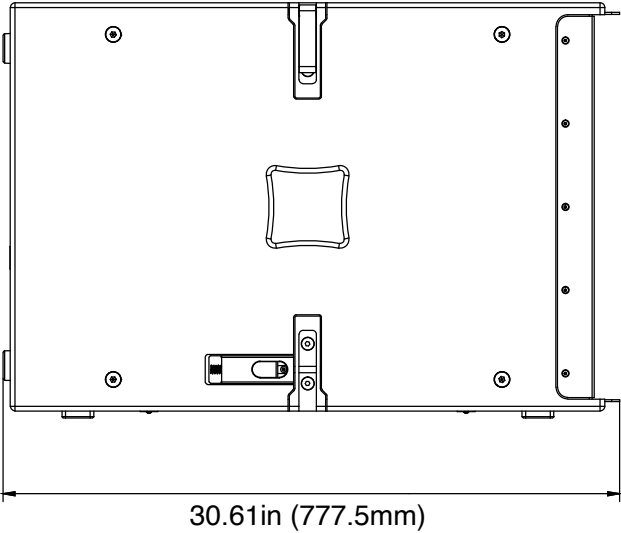
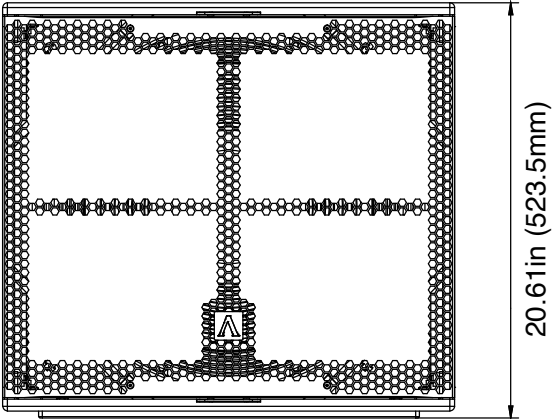

COMPONENTS & ACCESSORIES

SKU (US)	SKU (EU)	DESCRIPTION
IMC118	1163900040	Interlocking Caster Board
CVR118	1163900042	Protective Cover
IGS118	1163900041	Ground Stack Bar
Z-M10-58-3	N/A	M10 Fly Kit

FCC STATEMENT

This device complies with Part 15 of the FCC Rules. Operation is subject to the following two conditions: (1) this device may not cause harmful interference, and (2) this device must accept any interference received, including interference that may cause undesired operation.

FCC RADIO FREQUENCY INTERFERENCE WARNINGS & INSTRUCTIONS

This product has been tested and found to comply with the limits as per Part 15 of the FCC Rules. These limits are designed to provide reasonable protection against harmful interference in a residential installation. This device uses and can radiate radio frequency energy and, if not installed and used in accordance with the included instructions, may cause harmful interference to radio communications. However, there is no guarantee that interference will not occur in a particular installation. If this device does cause harmful interference to radio or television reception, which can be determined by turning the device off and on, the user is encouraged to try to correct the interference by one or more of the following methods:

- Reorient or relocate the device.
- Increase the separation between the device and the receiver.
- Connect the device and the radio receiver to electrical outlets on separate electrical circuits.
- Consult the dealer or an experienced radio/TV technician for help.



