

ELIMINATOR[®]

LIGHTING

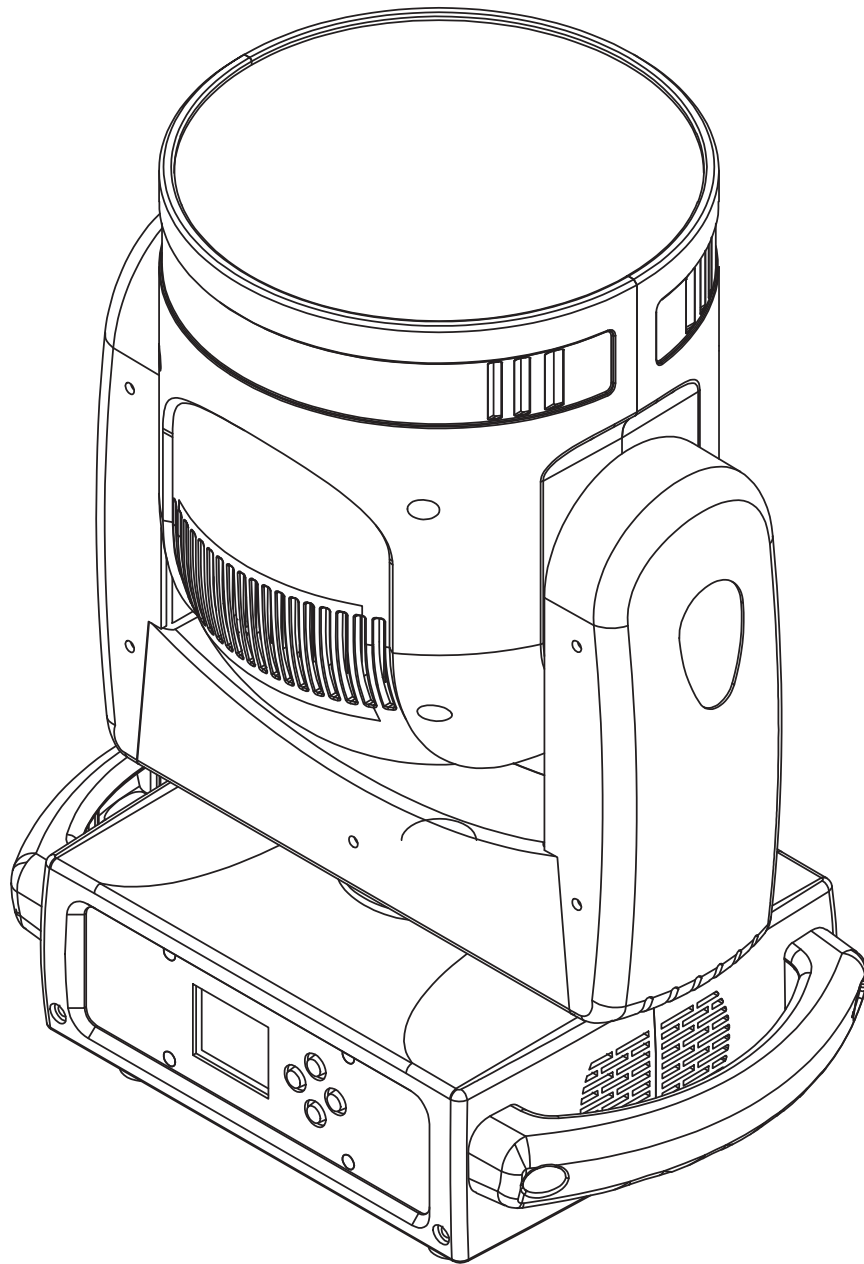

STRYKER MAX

User Manual

©2024 **Eliminator Lighting** all rights reserved. Information, specifications, diagrams, images, and instructions herein are subject to change without notice. Eliminator logo and identifying product names and numbers herein are trademarks of Eliminator Lighting. Copyright protection claimed includes all forms and matters of copyrightable materials and information now allowed by statutory or judicial law or hereinafter granted. Product names used in this document may be trademarks or registered trademarks of their respective companies and are hereby acknowledged. All non-Eliminator brands and product names are trademarks or registered trademarks of their respective companies.

Eliminator Lighting and all affiliated companies hereby disclaim any and all liabilities for property, equipment, building, and electrical damages, injuries to any persons, and direct or indirect economic loss associated with the use or reliance of any information contained within this document, and/or as a result of the improper, unsafe, insufficient and negligent assembly, installation, rigging, and operation of this product.

Eliminator Lighting

6122 S. Eastern Ave. Los Angeles, CA. 90040
 323-582-2650 | Fax 323-532-2941 | www.adj.com | info@adj.com

ADJ SUPPLY Europe B.V

Junostraat 2 6468 EW Kerkrade, The Netherlands
 +31 (0)45 546 85 00 | Fax +31 45 546 85 99
www.adj.eu | info@adj.eu

ADJ PRODUCTS GROUP Mexico

AV Santa Ana 30 Parque Industrial Lerma, Lerma, Mexico 52000
 +52 (728) 282-7070

DOCUMENT VERSION



Due to additional product features and/or enhancements, an updated version of this document may be available online. Please check www.adj.com for the latest revision/update of this manual before beginning installation and/or programming.

Date	Document Version	Software Version >	DMX Channel Mode	Notes
04/03/24	1.0	1.01Q	20 / 26 Ch	Initial release

CONTENTS

Introduction	4
Limited Warranty (USA Only)	5
Warranty Registration Features	6
Safety Guidelines	7
Overview	8
Installation	9
Remote Device Management (RDM)	13
Control Panel	14
System Menu	15
Target Mode	17
DMX Setup	18
DMX Traits	21
Primary-Secondary Mode Multi Unit Power Linking	23
Fuse Replacement Cleaning	24
Specifications	25
Dimensional Drawings	26
FCC Statement	27

INTRODUCTION

UNPACKING

Thank you for purchasing the Stryker Max by Eliminator Lighting. Every unit has been thoroughly tested and has been shipped in perfect operating condition. Carefully check the shipping carton for damage that may have occurred during shipping. If the carton appears to be damaged, carefully inspect your fixture for any damage and be sure all accessories necessary to operate the unit have arrived intact. In the event that damage has been found or parts are missing, please contact our toll free customer support number for further instructions. Do not return this unit to your dealer without first contacting customer support.

INTRODUCTION

This device is a DMX intelligent, LED powered moving head fixture, and can be used in stand alone mode or connected in a primary/secondary configuration. This wash has four operating modes: DMX control mode, primary-secondary mode, auto run mode, and sound mode. To optimize the performance of this product, please read these operating instructions carefully to familiarize yourself with the basic operations of this unit. These instructions contain important safety information regarding the use and maintenance of this unit. Please keep this manual with the unit for future reference.

CUSTOMER SUPPORT

Tel: (323) 213-4592 | Fax: (323) 582-2941

www.adj.com | support@eliminatorlighting.com

Warning! To prevent or reduce the risk of electrical shock or fire, do not expose this unit to rain or moisture.

Caution! There are no user serviceable parts inside this unit. Do not attempt any repairs yourself, as doing so will void your manufacturer's warranty. In the event that your unit requires service, please contact Eliminator Lighting for assistance.

PLEASE recycle the shipping carton when ever possible.

LIMITED WARRANTY (USA ONLY)

- A. Eliminator Lighting, an ADJ Products, LLC brand, hereby warrants, to the original purchaser, Eliminator Lighting products to be free of manufacturing defects in material and workmanship for a prescribed period from the date of purchase (see specific warranty period on reverse). This warranty shall be valid only if the product is purchased within the United States of America, including possessions and territories. It is the owner's responsibility to establish the date and place of purchase by acceptable evidence, at the time service is sought.
- B. For warranty service, you must obtain a Return Authorization number (RA#) before sending back the product—please contact ADJ Products, LLC Service Department at 800-322-6337. Send the product only to the Eliminator Lighting factory. All shipping charges must be pre-paid. If the requested repairs or service (including parts replacement) are within the terms of this warranty, Eliminator Lighting will pay return shipping charges only to a designated point within the United States. If the entire instrument is sent, it must be shipped in its original package. No accessories should be shipped with the product. If any accessories are shipped with the product, Eliminator Lighting shall have no liability whatsoever for loss of or damage to any such accessories, or for the safe return thereof.
- C. This warranty is void if the serial number has been altered or removed; if the product is modified in any manner which Eliminator Lighting concludes, after inspection, affects the reliability of the product, if the product has been repaired or service by anyone other than ADJ Products, LLC factory unless prior written authorization was issued to purchaser by Eliminator Lighting; if the product is damaged because not properly maintained as set forth in the instruction manual.
- D. This is not a service contract, and this warranty does not include maintenance, cleaning or periodic check up. During the period specified above, Eliminator Lighting will replace defective parts at its expense with new or refurbished parts, and will absorb all expenses for warranty service and repair labor by reason of defects in material or workmanship. The sole responsibility of Eliminator Lighting under this warranty shall be limited to the repair of the product, or replacement thereof, including parts, at the sole discretion of Eliminator Lighting. All products covered by this warranty were manufactured after August 15, 2012, and bear identifying marks to that effect.
- E. Eliminator Lighting reserves the right to make changes in design and/or improvements upon its products without any obligation to include these changes in any products theretofore manufactured.
- F. No warranty, whether expressed or implied, is given or made with respect to any accessory supplied with products described above. Except to the extent prohibited by applicable law, all implied warranties made by Eliminator Lighting in connection with this product, including warranties of merchantability or fitness, are limited in duration to the warranty period set forth above. And no warranties, whether expressed or implied, including warranties of merchantability or fitness, shall apply to this product after said period has expired. The consumer's and/or Dealer's sole remedy shall be such repair or replacement as is expressly provided above; and under no circumstances shall Eliminator Lighting be liable for any loss or damage, direct or consequential, arising out of the use of, or inability to use, this product.
- G. This warranty is the only written warranty applicable to Eliminator Lighting products and supersedes all prior warranties and written descriptions of warranty terms and conditions heretofore published.

MANUFACTURER'S LIMITED WARRANTY PERIODS

- **Non L.E.D. Eliminator Lighting products** = 1-year (365 days) Limited Warranty (Such as: Special Effect Lighting, Intelligent Lighting, UV lighting, Strobes, Fog Machines, Bubble Machines, Mirror Balls, Par Cans, Trussing, Lighting Stands etc., excluding lamps)
- **L.E.D. Eliminator Lighting Products** = 2-year (730 days) Limited Warranty (excluding batteries which have a 180 day limited warranty). Note: 2 Year Warranty only applies to purchases within the United States.
- **Eliminator Laser Products** = 1 Year (365 Days) Limited Warranty (excluding laser diodes which have a 6 month limited warranty)

WARRANTY REGISTRATION

This device carries a 2 year limited warranty. Please fill out the enclosed warranty card to validate your purchase. All returned service items, whether under warranty or not, must be freight pre-paid and accompanied by a return authorization (R.A.) number. The R.A. number must be clearly written on the outside of the return package. A brief description of the problem as well as the R.A. number must also be written down on a piece of paper included in the shipping carton. If the unit is under warranty, you must provide a copy of your proof of purchase invoice. You may obtain an R.A. number by contacting our customer support team on our customer support number. All packages returned to the service department not displaying an R.A. number on the outside of the package will be returned to the shipper.

FEATURES

- 3-pin XLR male / female signal connection
- 6 x 40W RGBW light source
- 60 x 0.5W RGB ring LEDs
- 2 DMX channel modes: 20-channel & 26-channel
- 4 - 55 degree zoom angle
- 540 degree pan movement
- 190 degree tilt movement
- DMX512, primary-secondary, auto run, or sound control mode
- RDM capability
- LCD display screen
- IP20 rating

SAFETY GUIDELINES

- To reduce the risk of electrical shock or fire, do not expose this unit to rain or moisture
- Do not spill water or other liquids into or on to your unit.
- Do not attempt to operate this unit if the power cord has been frayed or broken.
- Do not attempt to remove or break off the ground prong from the electrical cord. This prong is used to reduce the risk of electrical shock and fire in case of an internal short.
- Disconnect from main power before making any type of connection.
- Do not remove the cover for any reason. There are no user serviceable parts inside.
- Never operate this unit with the cover removed.
- Never plug this unit in to a dimmer pack.
- Always be sure to mount this unit in an area that will allow proper ventilation. Allow about 6” (15cm) between this device and a wall.
- Do not attempt to operate this unit if it has been damaged in any way.
- This unit is intended for indoor use only, and use of this product outdoors voids all warranties.
- During long periods of non-use, disconnect the unit from main power.
- Always mount this unit in safe and stable matter.
- Power-supply cords should be routed so that they are not likely to be walked on or pinched by items placed upon or against them, paying particular attention to the point at which they exit from the unit.
- Cleaning - The fixture should be cleaned only as recommended by the manufacturer. See the **Cleaning** section of this manual for details.
- Heat - The appliance should be situated away from heat sources such as radiators, heat registers, stoves, or other appliances (including amplifiers) that produce heat.
- The fixture should be serviced by qualified service personnel when:
 - A. The power-supply cord or the plug has been damaged.
 - B. Objects have fallen onto, or liquid has been spilled into, the appliance.
 - C. The appliance has been exposed to rain or water.
 - D. The appliance does not appear to operate normally or exhibits a marked change in performance.

OVERVIEW

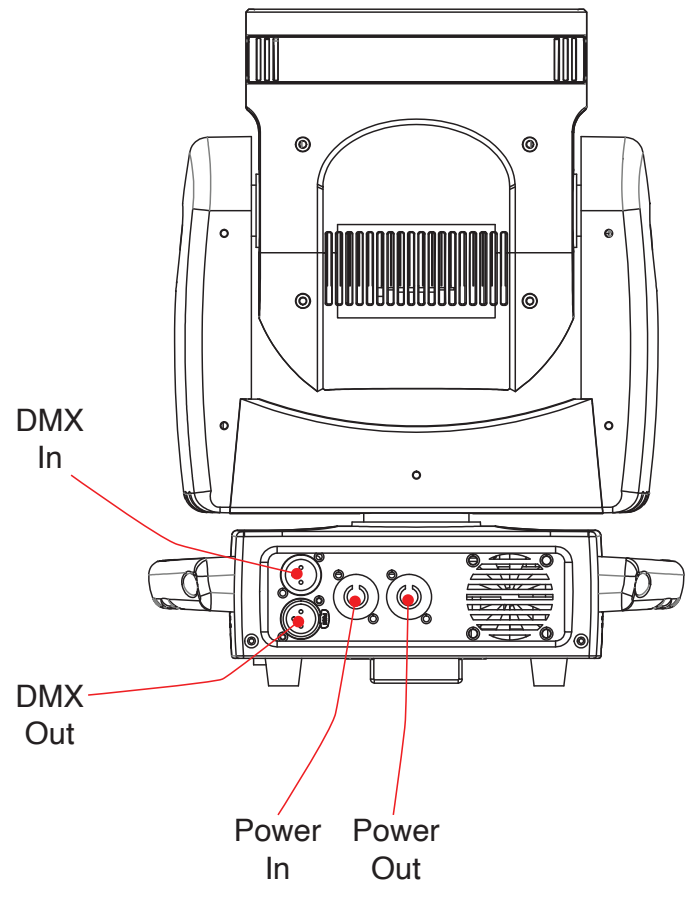
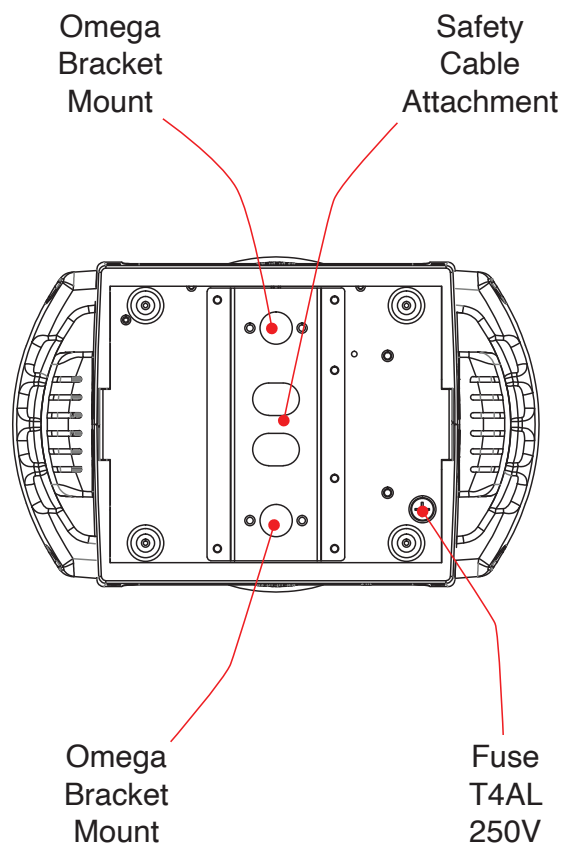
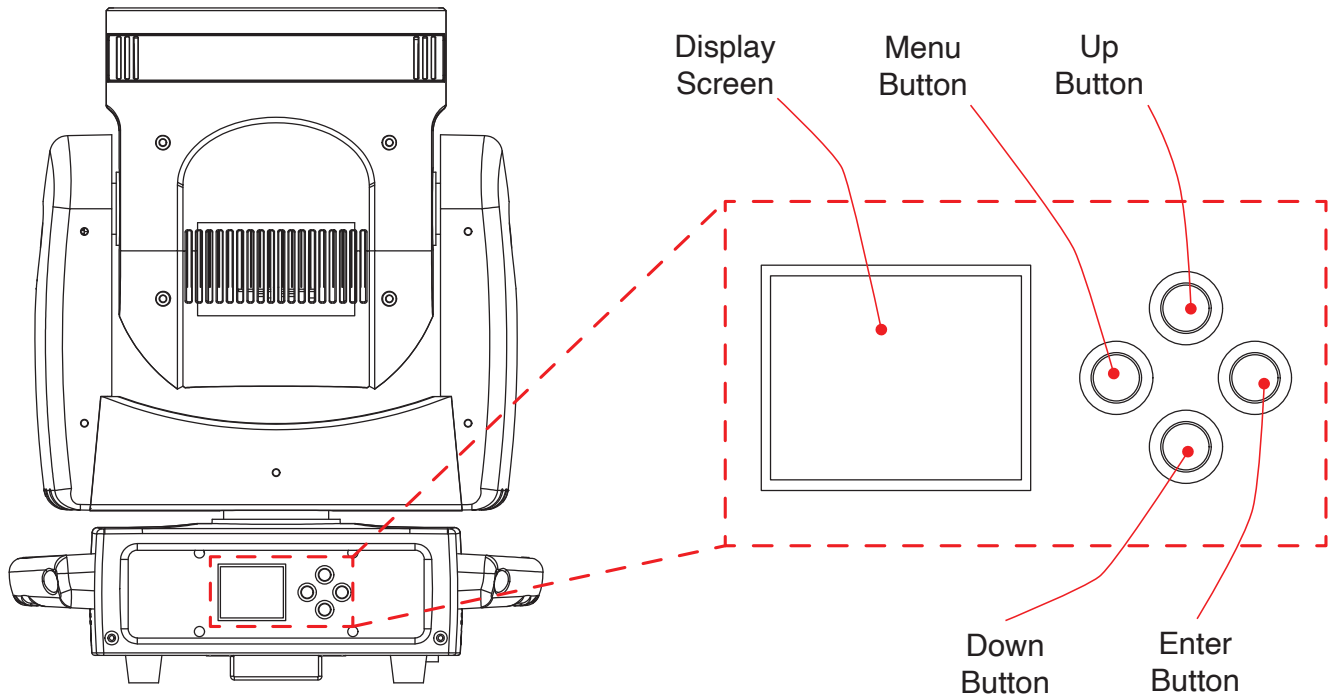

INSTALLATION



DO NOT INSTALL THE FIXTURE IF YOU ARE NOT QUALIFIED TO DO SO!

Fixture **MUST** be installed following all local, national, and country commercial electrical and construction codes and regulations.

When installing the unit, the trussing or area of installation must be able to hold 10 times the weight of the unit and any attached accessories without any deformation. The unit must be secured with a secondary safety attachment, e.g. an appropriately-rated safety cable.

Before rigging/mounting a single fixture to any metal truss/structure or placing the fixture(s) on any surface, a professional equipment installer **MUST** be consulted to determine if the metal truss/structure or surface is properly certified to safely hold the combined weight of the fixture(s), clamps, cables, and accessories.

Maximum ambient operating temperature is **113°F (45°C)**.

Fixture(s) should be installed away from walking paths, seating areas, or areas where unauthorized personnel might reach the fixture by hand.

NEVER stand directly below the fixture(s) when rigging, removing, or servicing.

Overhead fixture installation must always be secured with a secondary safety attachment, such as an appropriately rated safety cable that can hold 10 times the weight of the fixture.

Overhead mounting requires extensive experience, including calculating working load limits, knowledge of installation material being used, and periodic safety inspection of all installation material as well as the unit itself. If you lack these qualifications, do not attempt the installation yourself.

The installation should be checked by a skilled person once a year.

INSTALLATION

CLAMP MOUNTING

This fixture features mounting holes on the underside of the base for the installation of an Omega bracket. To truss mount this unit, attach a mounting clamp to an Omega bracket using an appropriately sized nut and bolt. Then, insert the twist lock fasteners of the Omega bracket into the outer holes of the mounting rail on the underside of the fixture, and twist to secure the clamp in place (see the illustration below). Attach a safety cable of the appropriate rating to the attachment point on the bracket's center section.

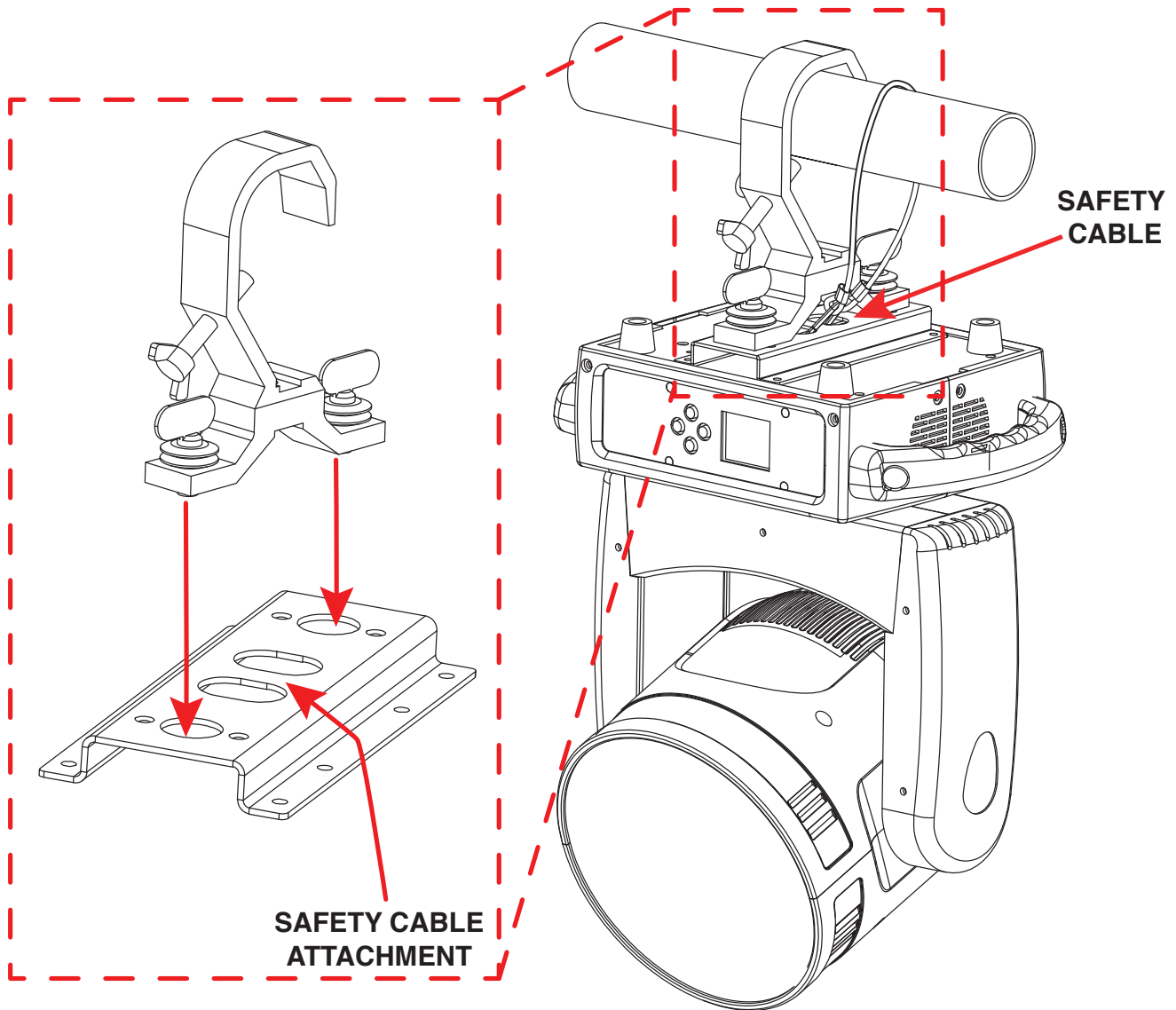

SAFETY CABLE:



ALWAYS ATTACH A SAFETY CABLE WHENEVER INSTALLING THIS FIXTURE IN A SUSPENDED ENVIRONMENT TO ENSURE THAT THE FIXTURE WILL NOT FALL IF THE CLAMP FAILS.

INSTALLATION

The unit is fully operational in three different mounting positions: hanging upside-down from the ceiling or trussing, sideways on trussing, or set on a flat level surface. Be sure this fixture is kept at least 12m (40ft) away from any flammable materials (decorations, etc). Always use and install a safety cable (not included) as a safety measure to prevent accidental damage and/or injury in the event the clamp fails.

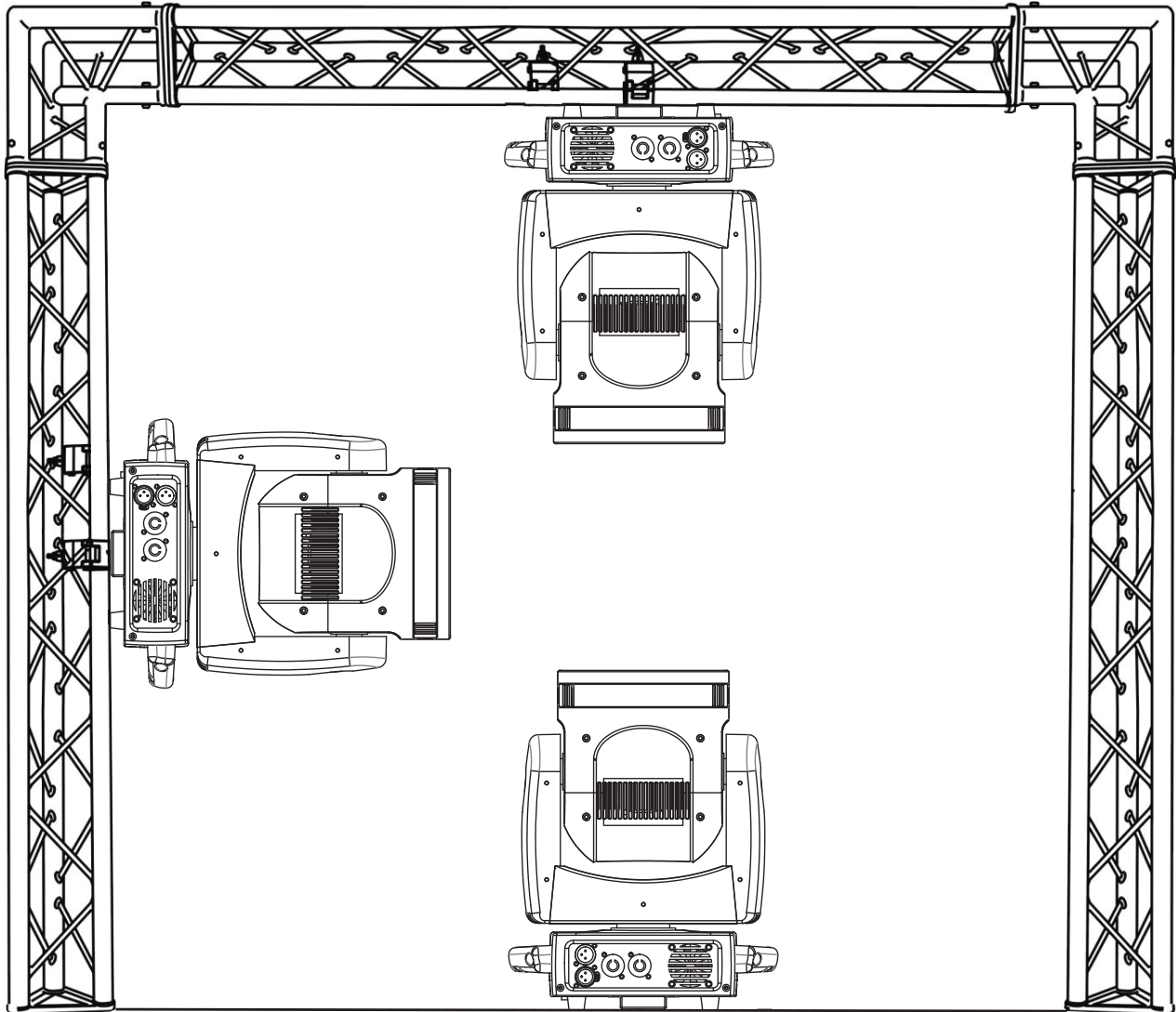

FALLING FIXTURES CAN CAUSE SEVERE INJURY OR SERIOUS EQUIPMENT DAMAGE! FOR THIS REASON, FIXTURES SHOULD BE INSTALLED AND INSPECTED ONLY BY QUALIFIED PERSONNEL. DO NOT INSTALL THE UNIT IF YOU LACK THE QUALIFICATIONS TO DO SO, OR IF YOU HAVE DOUBTS ABOUT THE SAFETY AND SECURITY OF THE INSTALLATION SETUP OR LOCATION!



ALWAYS ATTACH A SAFETY CABLE WHENEVER INSTALLING THIS FIXTURE IN A SUSPENDED ENVIRONMENT TO ENSURE THAT THE FIXTURE WILL NOT FALL IF THE CLAMP FAILS.

INSTALLATION

POTENTIAL INTERNAL FIXTURE DAMAGE FROM EXTERNAL SOURCES OF LIGHT BEAMS

External sources of light beams from direct sunlight, lighting and moving head fixtures, and lasers, which are focused directly towards the exterior housing and/or penetrate the front lens opening of Eliminator lighting fixtures, can cause severe internal damage including burning of optics, dichroic color filters, glass and metal gobos, prisms, animation wheels, frost filters, iris, shutters, motors, belts, wiring, discharge lamps, and LEDs.

This issue is not specific only to Eliminator lighting fixtures, but rather it is a common issue with lighting fixtures from all manufacturers. Although there is no true way to fully prevent this issue from happening, the guidelines below can reduce the risk of potential damage. Contact Eliminator Service for more details.

DO NOT EXPOSE THE FIXTURE AND/OR FRONT LENS OPENING TO LIGHT BEAMS FROM DIRECT SUNLIGHT, OTHER LIGHTING OR MOVING HEAD FIXTURES, AND LASERS DURING UNPACKING, INSTALLATION, USE, AND EXTENDED IDLE TIMES OUTDOORS. DO NOT FOCUS A LIGHT BEAM FROM ONE LIGHTING FIXTURE DIRECTLY TOWARDS ANOTHER.

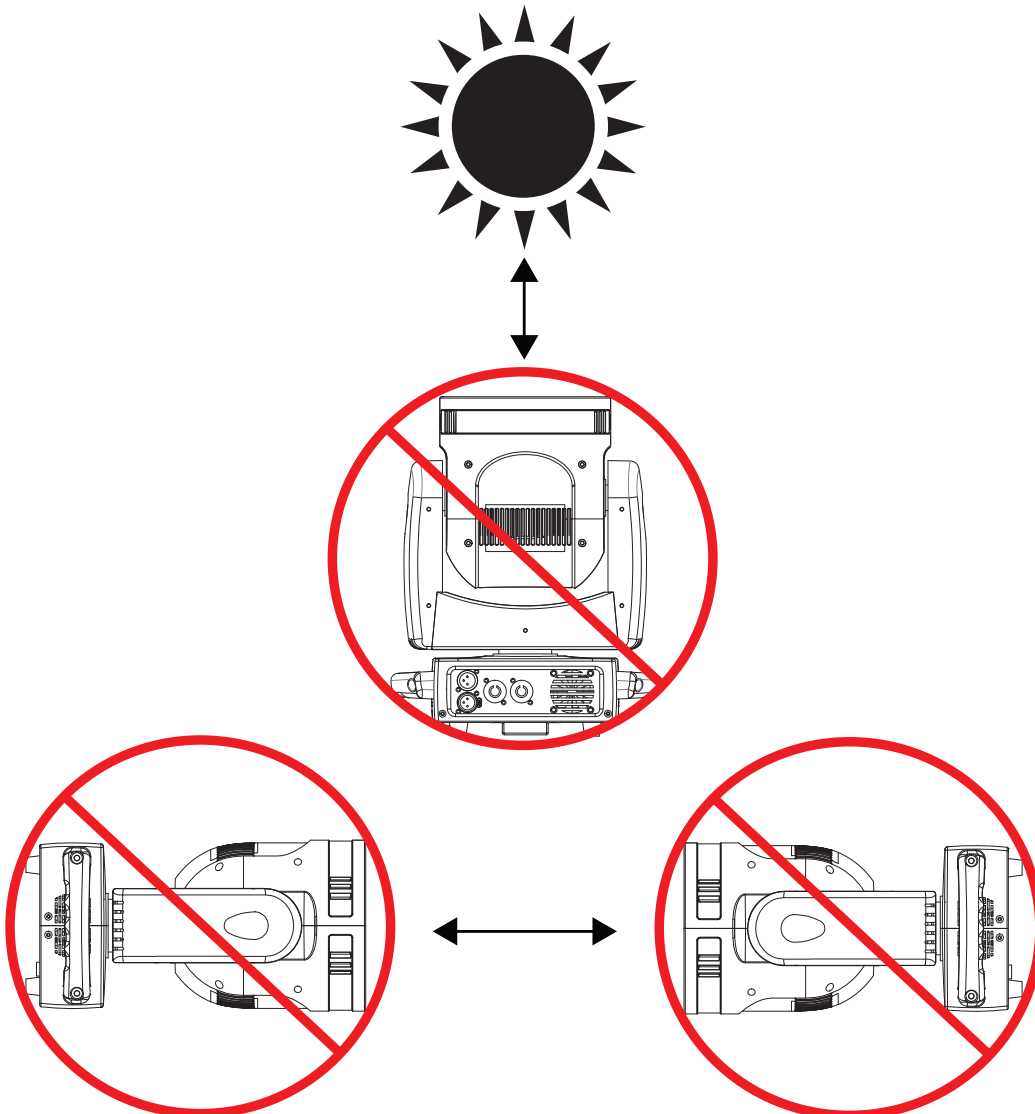

REMOTE DEVICE MANAGEMENT (RDM)

NOTE: In order for RDM to work properly, RDM enabled equipment must be used throughout the entire system, including DMX data splitters and wireless systems.

Remote Device Management (RDM) is a protocol that sits on top of the DMX512 data standard for lighting, allowing the DMX systems of the fixtures to be modified and monitored remotely. This protocol is ideal for instances in which a unit is installed in a location that is not easily accessible.

With RDM, the DMX512 system becomes bi-directional, allowing a compatible RDM enabled controller to send out a signal to devices on the wire, as well as allowing the fixture to respond (known as a *GET* command). The controller can then use its *SET* command to modify settings that would typically have to be changed or viewed directly via the unit's display screen, including the DMX Address, DMX Channel Mode, and Temperature Sensors.

FIXTURE RDM INFORMATION:

RDM Code	Device ID	Device Model ID	Personality ID
0x1997	Random	0x0001	CH20 (1) CH26 (2)

Please be aware that not all RDM devices support all RDM features, and therefore it is important to check beforehand to ensure that the equipment that you are considering includes all of the features that you require.

[0x0200] Sensor Definition	[0x0601] Tilt Invert
[0x0201] Sensor Value	[0x0602] Pan Tilt Swap
[0x0080] Device Model Description	[0x0500] Display Invert
[0x0081] Manufacturer Label	[0x0501] Display Level
[0x0082] Device Label	[0x0603] Real Time Clock
[0x00E0] DMX Personality	[0x1010] Power State
[0x00E1] DMX Personality Description	[0x1031] Preset Playback
[0x0400] Device Hours	[0x0120] Slot Info
[0x0015] Comms Status	[0x0121] Slot Description
[0x0031] Status ID Description	[0x0122] Default Slot Value
[0x0032] Clear Status ID	[0x00B0] Language
[0x0401] Lamp Hours	[0x00A0] Language Capabilities
[0x0402] Lamp Strikes	[0x00C2] Boot Software Version Label
[0x0403] Lamp State	[0x00C1] Boot Software Version ID
[0x0404] Lamp On Mode	[0x0070] Product Detail ID List
[0x0405] Device Power Cycles	[0x0030] Status Messages
[0x0600] Pan Invert	

CONTROL PANEL

This fixture features a display screen with a 4-button control pad, which can be used to easily adjust any device settings.

Pressing the MENU button will cycle through the various Main Menu options. When the desired Main Menu option is displayed on the screen, press the ENTER button to enter the sub-menu, then use the UP and DOWN buttons to scroll through sub-menu options. In some cases, there will be a second sub-menu that can be navigated in the same way.

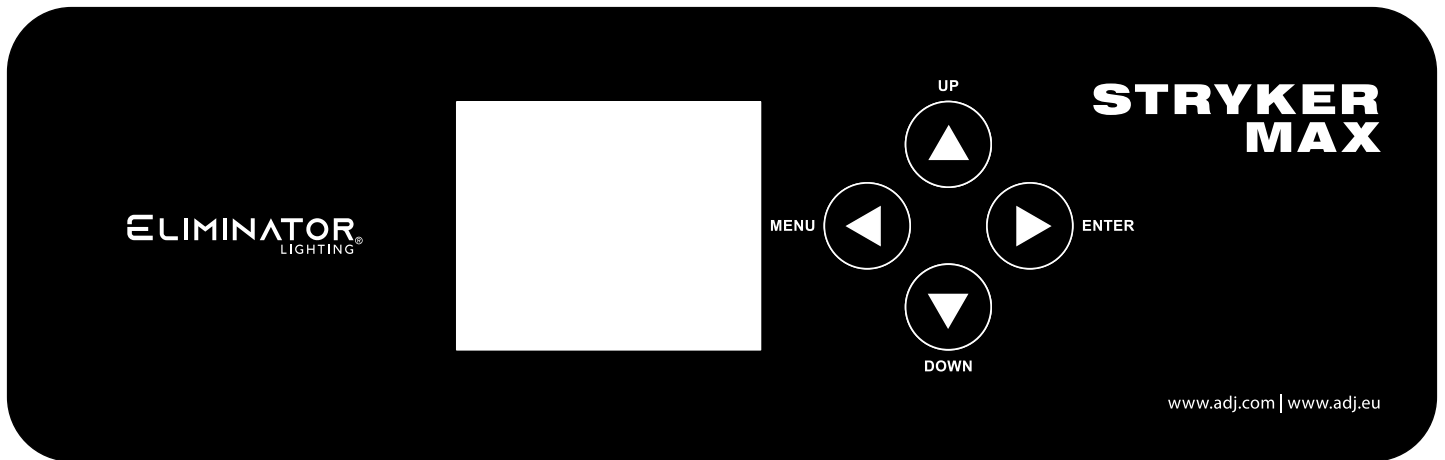

SYSTEM MENU

DMX SETTINGS	Address	001 - 512		Set DMX address
	Mode	20 Ch		Select DMX channel mode
		26 Ch		
	No DMX	Hold		Unit holds last settings received when DMX signal is lost or interrupted
Sound		Unit defaults to sound mode when DMX signal is lost or interrupted		
PERSONALITY	Pri / Sec Mode	Primary / Secondary		Set unit as a primary or secondary
	Pan Invert	Yes / No		Invert pan motion
	Tilt Invert	Yes / No		Invert tilt motion
	P/T Correction	On / Off		Enable or disable pan/tilt correction
	Display Reverse	Yes / No		Invert display orientation
	Display Intensity	001 - 010		Set display intensity
	Target Mode	Off / On		Enable or disable target mode
	Sound Sensitivity	000 - 100 (default = 010)		Adjust sound sensitivity level
	Reset	Yes / No		Reset unit
	Factory Restore	Password = 018		Restore unit to factory default settings
	Calibration	Password = 018		Calibrate each unit parameter
		Pan	-127 ~ 128	
Tilt		-127 ~ 128		
Red		-127 ~ 128		
Green		-127 ~ 128		
Blue		-127 ~ 128		
White		-127 ~ 128		
...		...		
Zoom	-127 ~ 128			

SYSTEM MENU

RUN MODE	Program	Internal Program 1	Select target mode program
		Internal Program 2	
		Internal Program 3	
		Internal Program 4	
		Internal Program 5	
		Internal Program 6	
		Internal Program 7	
		Internal Program 8	
	Program Speed	1 - 10 (default = 5)	Set program speed. 1 is slowest, 10 is fastest
MANUAL MODE	Pan	000 - 255	Manually set each unit parameter
	Pan fine	000 - 255	
	Tilt	000 - 255	
	Tilt Fine	000 - 255	
	Red	000 - 255	
	Green	000 - 255	
	Blue	000 - 255	
	White	000 - 255	
	CCT Presets	000 - 255	
	Color Macros	000 - 255	
	
	Shutter	000 - 255	
	Dimmer	000 - 255	
	Dimmer Fine	000 - 255	
	Pan / Tilt Speed	000 - 255	
Reset	000 - 255		
SYS INFO	On Time	xxH xxM	Display current run time
	Total Time	xxxxxxH xxM	Display total lifetime run time
	Firmware Version	Vx.xxx	Display current software version
	Running Mode	DMX xx Ch	Display currently selected DMX channel mode
	Temperature	xxx° F	Display current unit temperature

TARGET MODE

Target modes restrict the pan and tilt movement of the fixture to a certain pre-defined range. To set the unit to operate in target mode, first navigate to Personality > Target Mode in the system menu, then select "On". Then navigate to Run Mode > Program in the system menu to select which target mode setting you would like to run. The parameters of each target mode are shown in the diagram below. Additionally, the operation speed of the selected target mode can be adjusted.

MODE 1 Pan Movement Range=270°

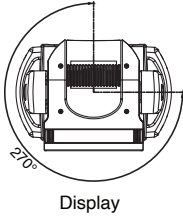

Tilt Movement Range=40°

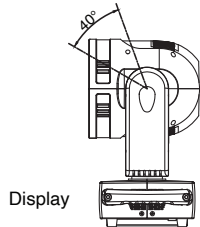

MODE 5 Pan Movement Range=270°

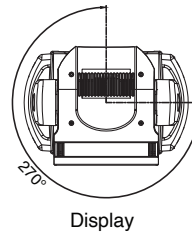

Tilt Movement Range=40°

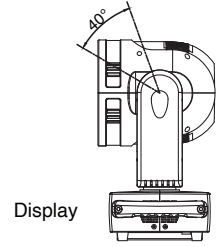

MODE 2 Pan Movement Range=270°

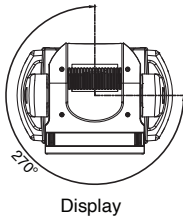

Tilt Movement Range=40°

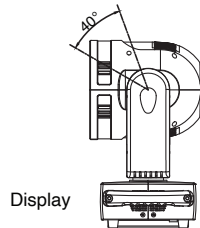

MODE 6 Pan Movement Range=270°

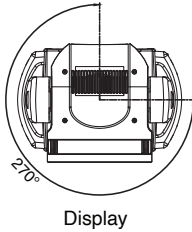

Tilt Movement Range=40°

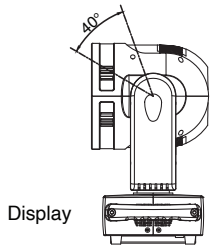

MODE 3 Pan Movement Range=270°

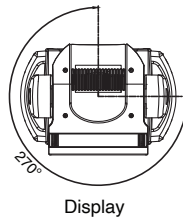

Tilt Movement Range=40°

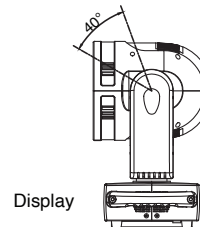

MODE 7 Pan Movement Range=0°

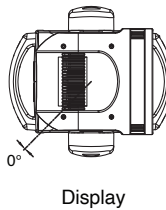

Tilt Movement Range=0°

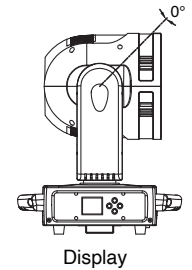

MODE 4 Pan Movement Range=270°

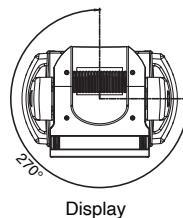

Tilt Movement Range=40°

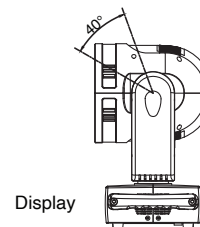

MODE 8 Pan Movement Range=0°

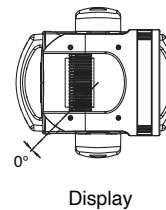

Tilt Movement Range=0°

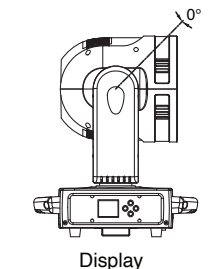

DMX SETUP

DMX-512: DMX is short for Digital Multiplex. This is a universal protocol used as a form of communication between intelligent fixtures and controllers. A DMX controller sends DMX data instructions from the controller to the fixture. DMX data is sent as serial data that travels from fixture to fixture via the DATA “IN” and DATA “OUT” XLR terminals located on all DMX fixtures (most controllers only have a DATA “OUT” terminal).

DMX Linking: DMX is a language allowing all makes and models of different manufacturers to be linked together and operate from a single controller, as long as all fixtures and the controller are DMX compliant. To ensure proper DMX data transmission, try to use the shortest cable path possible when linking several DMX fixtures. The order in which fixtures are connected in a DMX line does not influence the DMX addressing. For example, a fixture assigned a DMX address of 1 may be placed anywhere in a DMX line: at the beginning, at the end, or anywhere in the middle. When a fixture is assigned a DMX address of 1, the DMX controller knows to send DATA assigned to address 1 to that unit, no matter where it is located in the DMX chain.

Data Cable (DMX Cable) Requirements (For DMX Operation): This unit can be controlled via DMX-512 protocol and features 2 selectable DMX modes. Please refer to the **DMX Traits** section of this manual for detailed information. The DMX address can be set using the controls on the rear panel of the unit. Your unit and your DMX controller require a 3-pin XLR connector for data input/output. We recommend Accu-Cable DMX cables. If you are making your own cables, be sure to use standard 110-120 Ohm shielded cable (This cable may be purchased at almost all pro lighting stores). Your cables should be made with a male XLR connector on one end and a female XLR connector on the other. Also remember that DMX cable must be daisy chained and cannot be split.



DMX SETUP

Notice: Be sure to the figures below when making your own cables. Do not use the ground lug on the XLR connector. Do not connect the cable's shield conductor to the ground lug or allow the shield conductor to come in contact with the XLR's outer casing. Grounding the shield could cause a short circuit and erratic behavior.

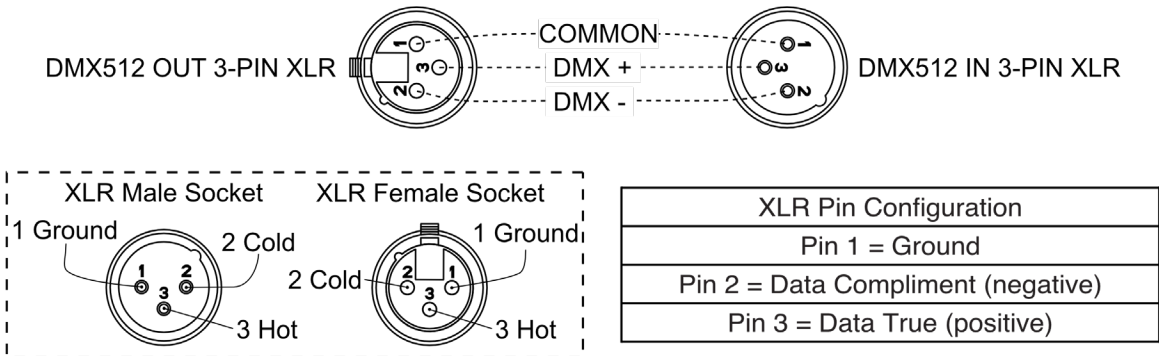

Special Note: Line Termination. When longer runs of cable are used, you may need to use a terminator on the last unit to avoid erratic behavior. A terminator is a 110-120 ohm 1/4 watt resistor which is connected between pins 2 and 3 of a male XLR connector (DATA + and DATA -). This unit is inserted in the female XLR connector of the last unit in your daisy chain to terminate the line. Using a cable terminator (ADJ part number Z-DMX/T) will decrease the possibilities of erratic behavior.

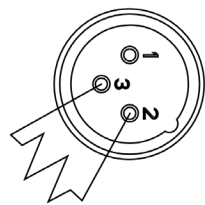

A DMX512 terminator reduces signal errors, avoiding most signal reflection interference. Connect PIN 2 (DMX-) and PIN 3 (DMX+) of the last fixture in series with a 120 Ohm, 1/4 W Resistor to terminate the DMX512.

5-Pin XLR DMX Connectors: Some manufacturers use 5-pin DMX-512 data cables for DATA transmission in place of 3-pin. 5-pin DMX fixtures may be integrated into a 3-pin DMX line with a 5-pin to 3-pin adapter cable. These adapters are readily available at most electronics stores. Follow the chart below for a proper conversion.

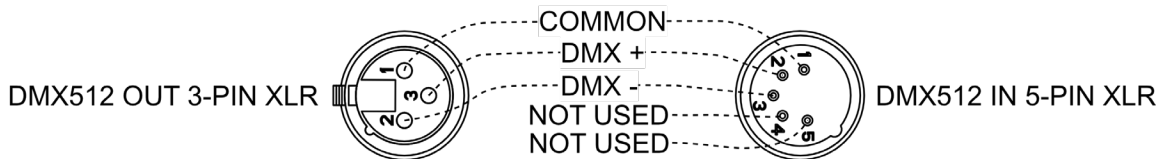

3-Pin XLR to 5-Pin XLR Conversion		
Ground/Shield	Pin 1	Pin 1
Data Compliment (- signal)	Pin 2	Pin 2
Data True (+ signal)	Pin 3	Pin 3
Not Used		Do Not Use
Not Used		Do Not Use

DMX SETUP

DMX Addressing:

All fixtures should be given a DMX starting address when using a DMX controller, in order to ensure that the correct fixture responds to the correct control signal. This digital starting address is the channel number from which the fixture starts to “listen” to the digital control signal sent out from the DMX controller. The assignment of this starting DMX address is achieved by setting the correct DMX address on the digital control display on the fixture.

You can set the same starting address for all fixtures or a group of fixtures, or set different addresses for each individual fixture. Setting all fixtures to the same DMX address will cause all fixtures to react in the same way; in other words, changing the settings of one channel will affect all the fixtures simultaneously.

If you set each fixture to a different DMX address, each unit will start to “listen” to the channel number you have set, based on the quantity of DMX channels of each fixture. That means changing the settings of one channel will only affect the selected fixture. For instance, when this unit is set to 20 Channel mode, you should set the starting DMX address of the first unit to 1, the second unit to 21 (1 + 20), the third unit to 41 (1 + 20 + 20), the fourth unit to 61 (1 + 20 + 20 + 20), etc...

Channel Mode	Unit 1 Address	Unit 2 Address	Unit 3 Address	Unit 4 Address
20Ch	1	21	41	61
26Ch	1	27	53	79

DMX TRAITS

CHANNEL		DMX VALUES	FUNCTION
20Ch	26Ch		
1	1	000 - 255	Pan , 8-bit, 0° - 540°
	2	000 - 255	Pan Fine , 16-bit
2	3	000 - 255	Tilt , 8-bit, 0° - 190°
	4	000 - 255	Tilt Fine , 16-bit
3	5	000 - 255	Red
4	6	000 - 255	Green
5	7	000 - 255	Blue
6	8	000 - 255	White
	9	000 - 255	Hue
	10	000 - 255	Saturation
	11		CCT Presets
		000	No Function
		001 - 027	2800K
		028 - 055	3200K
		056 - 083	3600K
		084 - 111	4500K
		112 - 139	5000K
		140 - 167	5600K
		168 - 195	6200K
		196 - 223	6800K
		224 - 251	7500K
	252 - 255	8500K	
7	12		Color Macros
		000	Off
		001 - 255	Color Macros, Macro 1 - Macro 255
8	13		Effect
		000	Effect Off
		001 - 100	Wave
		101 - 200	Dream
	201 - 255	Color Chase	
9	14	000 - 255	Glory Red
10	15	000 - 255	Glory Green
11	16	000 - 255	Glory Blue
12	17	000 - 255	Glory Dimmer
13	18		Glory Effect
		000 - 015	Glory Effect close
		016 - 035	Glory single LED effect
		036 - 055	Glory 3pcs LED effect
		056 - 075	Glory 6pcs LED effect
		076 - 095	Glory 12pcs LED effect
096 - 115	Glory 3pcs LED-4 modules effect		

DMX TRAITS

CHANNEL		DMX VALUES	FUNCTION
20Ch	26Ch		
13	18		Glory Effect (continued)
		116 - 135	Glory 6pcs LED-4 modules effect
		136 - 155	Glory 4 modules effect
		156 - 175	Glory loop fill effect
		176 - 195	RGB 3 colors rainbow effect
		196 - 215	RGB 3 colors effect
		216 - 235	Glory rainbow effect
		236 - 255	Glory segment effect
14	19	000 - 255	Glory Speed
15	20	000 - 255	Zoom , minimum to maximum
16	21		Inner Rotate
		000 - 127	Positions
		128 - 190	Clockwise, fast to slow
		191 - 192	Stop
		193 - 255	Counter-clockwise, slow to fast
17	22		Shutter
		000 - 003	Off
		004 - 127	Strobe, slow to fast
		128 - 191	Pulse Strobe, slow to fast
		192 - 251	Random Strobe, slow to fast
252 - 255	Open		
18	23	000 - 255	Dimmer , 0-100%
	24	000 - 255	Dimmer Fine , 16-bit
19	25	000 - 255	Pan/Tilt Speed , fast to slow
20	26		Reset
		000 - 021	Off
		022 - 025	No Function
		026 - 076	Reset Effect (hold 3 sec)
		077 - 128	Reset Pan/Tilt Motor (hold 3 sec)
		129 - 255	Reset All (hold 3 sec)

PRIMARY-SECONDARY MODE

This function will allow you to link units together to run in a Primary-Secondary set-up, in which one unit will act as the controlling unit, and the others will react to the controlling unit's built-in programs. Any unit can act as a Primary or a Secondary, but only one unit in a given system can be programmed to act as the Primary.

Connections and Settings:

1. Daisy chain your units via the XLR connectors on the rear panel of each unit. Use standard XLR data cables to link your units together. Remember that the male XLR connector is the input and the female XLR connector is the output. The first unit in the chain (primary) will use the female XLR connector only, and the last unit in the chain will use the male XLR connector only.
2. In each unit, navigate to Personality > Pri/Sec Mode in the system menu, then press ENTER.
3. Use the UP and DOWN buttons to set each unit as a primary or a secondary, as desired. Remember that only one unit in a given system may be defined as the primary, and all others must be designated as secondaries.
4. Return to your primary unit, and configure the unit as desired. The secondary unit(s) will now follow the programming of the primary unit.

MULTI UNIT POWER LINKING

This feature allows you to connect the fixtures to one another using the power cable input and output sockets.

The maximum number of units that can be linked in this manner is as follows:

- 2 units @ 110V power
- 3 units @ 220V power

DO NOT EXCEED THIS MAXIMUM NUMBER WHEN POWER LINKING UNITS!

All linked units must be of the same make and model type. Do not mix and match units!

FUSE REPLACEMENT

Disconnect the unit from its power source, and remove the power cord from the unit. The fuse is located on the underside of the unit, as shown in the illustration below. Remove the bad fuse and replace with a new one. **Replace only with a new fuse of the same T4AL 250V rating!**

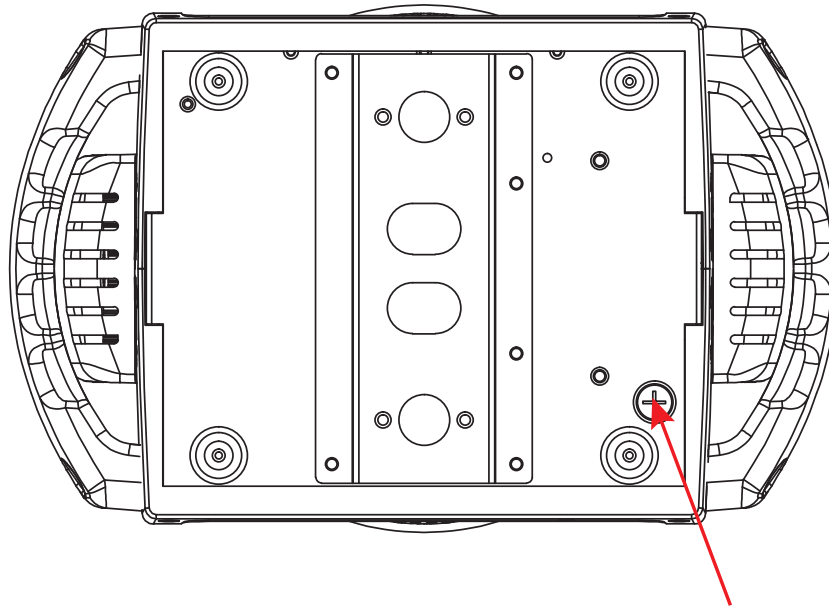

**FUSE
T4AL 250V**

CLEANING

Due to fog residue, smoke, and dust, cleaning the internal and external optical lenses must be carried out periodically to optimize light output.

- Periodically use normal glass cleaner and a soft cloth to wipe down the outside casing and external optics.
- Always be sure to dry all parts completely before plugging the unit back in.

Cleaning frequency depends on the environment in which the fixture operates (i.e. smoke, fog residue, dust, dew).

SPECIFICATIONS

Light Source:

- 6 x 40-Watt Quad (RGBW) LEDs
- LED Ring: 60 x .5-Watt RGB LEDs

Features:

- Motorized Zoom: 4 ~ 55-degrees
- Create eye candy effects with LED Ring
- Variable White Color Temperatures: 2800K – 8500K
- Built-in Color Macros & Effects
- 0-100% smooth dimming
- Variable speed strobe effect
- Fast, precise, pan & tilt movements

Control:

- DMX Channel Modes: 20 or 26 channels
- Operational Modes: DMX512 / Primary-Secondary / Auto Run / Sound / RDM
- OLED Menu Display

Connections:

- 3-pin DMX In/Out
- Locking Input & Output connections to daisy chain power

Pan/Tilt:

- Pan: 540°
- Tilt: 190°
- 16-bit Fine Pan
- 16-bit Fine Tilt

Electrical:

- Multi-voltage operation: 100-240V, 50/60Hz
- Maximum power draw: 260-Watts

Dimensions & Weight:

- Dimensions (LxWxH): 14.6" x 11.5" x 7.1" / 370mm x 292mm x 180mm
- Weight: 16.5 lbs. / 7.5 kg.

Approvals:

- IP20



DIMENSIONAL DRAWINGS

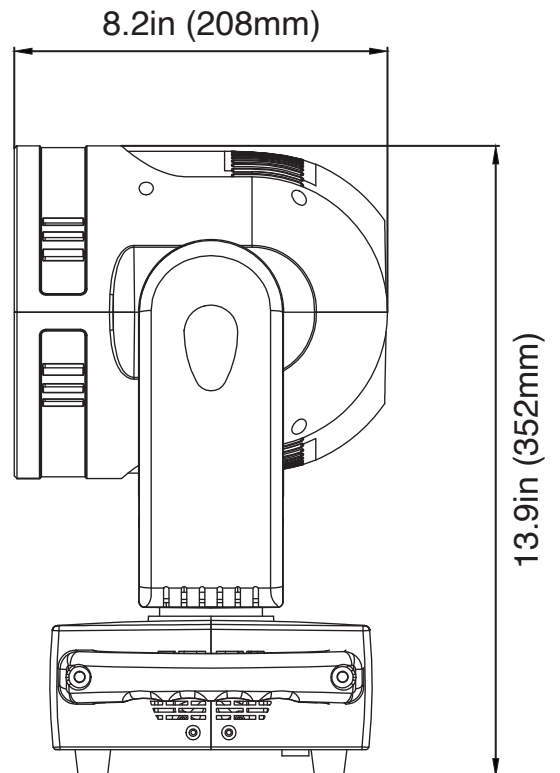
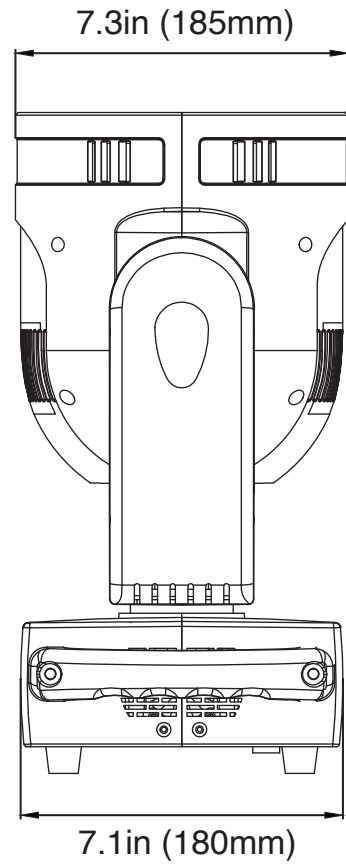
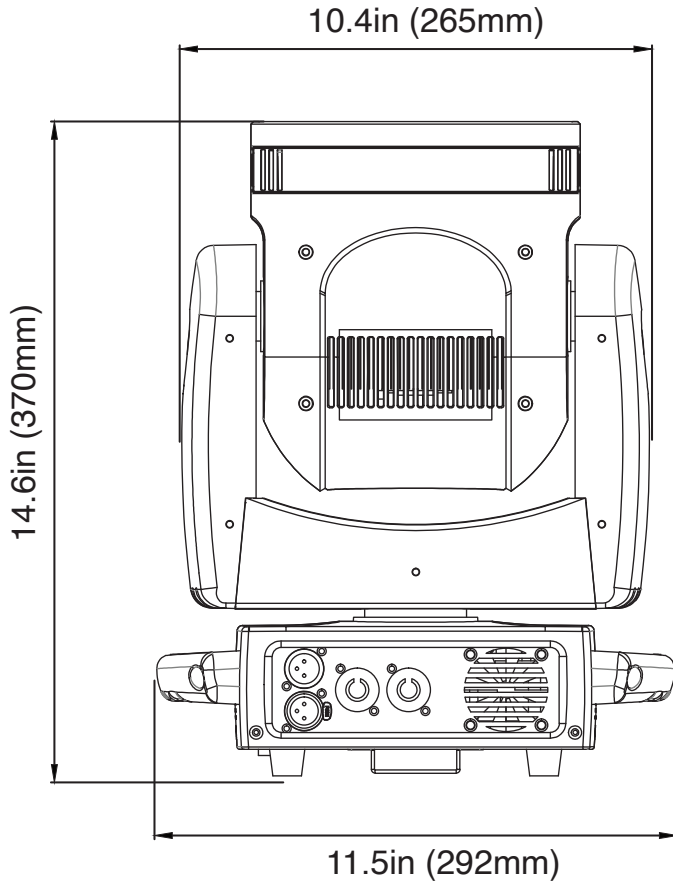

FCC STATEMENT

This device complies with Part 15 of the FCC Rules. Operation is subject to the following two conditions: (1) this device may not cause harmful interference, and (2) this device must accept any interference received, including interference that may cause undesired operation.

FCC RADIO FREQUENCY INTERFERENCE WARNINGS & INSTRUCTIONS

This product has been tested and found to comply with the limits as per Part 15 of the FCC Rules. These limits are designed to provide reasonable protection against harmful interference in a residential installation. This device uses and can radiate radio frequency energy and, if not installed and used in accordance with the included instructions, may cause harmful interference to radio communications. However, there is no guarantee that interference will not occur in a particular installation. If this device does cause harmful interference to radio or television reception, which can be determined by turning the device off and on, the user is encouraged to try to correct the interference by one or more of the following methods:

- Reorient or relocate the device.
- Increase the separation between the device and the receiver.
- Connect the device to an electrical outlet on a circuit different from which the radio receiver is connected.
- Consult the dealer or an experienced radio/TV technician for help.

Energy Saving Matters (EuP 2009/125/EC)

Saving electric energy is a key to help protecting the environment. Please turn off all electrical products when they are not in use. To avoid power consumption in idle mode, disconnect all electrical equipment from power when not in use. Thank you!



