

ELEMENT H IP
ELEMENT H IP CHROME
User Instructions

©2023 ADJ Products, LLC all rights reserved. Information, specifications, diagrams, images, and instructions herein are subject to change without notice. ADJ Products, LLC logo and identifying product names and numbers herein are trademarks of ADJ Products, LLC. Copyright protection claimed includes all forms and matters of copyrightable materials and information now allowed by statutory or judicial law or hereinafter granted. Product names used in this document may be trademarks or registered trademarks of their respective companies and are hereby acknowledged. All non-ADJ Products, LLC brands and product names are trademarks or registered trademarks of their respective companies.

ADJ Products, LLC and all affiliated companies hereby disclaim any and all liabilities for property, equipment, building, and electrical damages, injuries to any persons, and direct or indirect economic loss associated with the use or reliance of any information contained within this document, and/or as a result of the improper, unsafe, insufficient and negligent assembly, installation, rigging, and operation of this product.

ADJ PRODUCTS LLC World Headquarters

6122 S. Eastern Ave. | Los Angeles, CA 90040 USA
 Tel: 800-322-6337 | Fax: 323-582-2941 | www.adj.com | support@adj.com

ADJ Supply Europe B.V.

Junostraat 2 | 6468 EW Kerkrade | Netherlands
 Tel: +31 45 546 85 00 | Fax: +31 45 546 85 99 | www.americandj.eu | service@americandj.eu

RISK GROUP 3 - RISK OF EXPOSURE TO ULTRAVIOLET (UV) RADIATION!



HIGH INTENSITY ULTRAVIOLET LIGHT

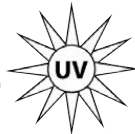

AVOID DIRECT EYE & SKIN EXPOSURE.
 WEAR PROPER EYE & SKIN PROTECTION.
 SEE MANUAL FOR SAFETY INSTRUCTIONS.

FIXTURE EMITS HIGH INTENSITY WAVELENGTH OF ULTRAVIOLET LIGHT. WEAR PROPER EYE AND SKIN PROTECTION. DO NOT OPERATE FIXTURE WITH DAMAGED/MISSING EXTERNAL COVER OR PROTECTIVE LENS. DO NOT LOOK DIRECTLY INTO THE (UV) LIGHT AND/OR VIEW (UV) LIGHT DIRECTLY WITH OPTICAL INSTRUMENTS THAT MAY CONCENTRATE THE LIGHT/RADIATION OUTPUT. AVOID PROLONGED PERIODS OF EXPOSURE. AVOID WEARING WHITE COLOR CLOTHING AND/OR USING (UV) PAINTS ON SKIN. AVOID DIRECT EYE AND/OR SKIN EXPOSURE AT DISTANCES SHORTER THAN 11 FEET (3.3 METERS). INDIVIDUALS SUFFERING FROM A RANGE OF EYE CONDITIONS, SUNLIGHT EXPOSURE DISORDERS, OR INDIVIDUALS USING PHOTSENSITIVE MEDICATION MAY EXPERIENCE DISCOMFORT IF EXPOSED TO THE

ULTRAVIOLET (UV) LIGHT EMITTED FROM THIS FIXTURE.

Europe Energy Saving Notice

Energy Saving Matters (EuP 2009/125/EC)

Saving electric energy is a key to help protecting the environment. Please turn off all electrical products when they are not in use. To avoid power consumption in idle mode, disconnect all electrical equipment from power when not in use. Thank you!

DOCUMENT VERSION



Due to additional product features and/or enhancements, an updated version of this document may be available online.

Please check www.adj.com for the latest revision/update of this manual before beginning installation and/or programming.

Date	Document Version	Software Version	DMX Channels	Notes
01/30/2023	1	1.00	6 / 8 / 9 / 12 / 14 / 15 / 17 ch.	Initial Version
04/24/2023	1.1	N/C	N/C	Added Battery Replacement Instructions
08/31/2023	1.2	N/C	N/C	Updated Features, Overview, Battery Replacement, IR Default Values, Torque Settings for Screws, Specifications
09/29/2023	1.3	N/C	N/C	FCC Approved

CONTENTS

General Information	4
Key Features Warranty Returns	5
Limited Warranty (USA Only)	6
Safety Guidelines	7
Overview	9
Wireless Setup	10
UC IR Remote	11
Installation	12
Battery	16
Charging	16
Replacement	17
Information	19
System Menu	20
DMX Addressing	24
DMX Traits	25
IR Default Values Editing RGBA IR Button Values	27
Color Macros	28
White Color Temperature Presets	29
Dimmer Curves and Dimmer Modes	30
Cleaning & Maintenance	31
Torque Settings for Screws	32
Dimensional Drawings	33
Specifications	34
FCC Statement	35

GENERAL INFORMATION

INTRODUCTION

Please read and understand the instructions in this manual carefully and thoroughly before attempting to operate this device. These instructions contain important safety and use information.

This product is intended for use by professionally trained personnel only, and is not suitable for private use.

UNPACKING

Every device has been thoroughly tested and has been shipped in perfect operating condition. Carefully check the shipping carton for damage that may have occurred during shipping. If the carton is damaged, carefully inspect the device for damage, and be sure all accessories necessary to install and operate the device have arrived intact. In the event damage has been found or parts are missing, please contact our customer support team for further instructions. Please do not return this device to your dealer without first contacting customer support. Please do not discard the shipping carton in the trash. Please recycle whenever possible.

CUSTOMER SUPPORT

Contact ADJ Service for any product related service and support needs.

Also visit forums.adj.com with questions, comments or suggestions.

ADJ SERVICE USA - Monday - Friday 8:00am to 4:30pm PST

323-582-2650 | Fax: 323-832-2941 | support@adj.com

ADJ SERVICE EUROPE - Monday - Friday 08:30 to 17:00 CET

+31 45 546 85 60 | Fax: +31 45 546 85 96 | www.adj.eu | info@adj.eu

REPLACEMENT PARTS please visit parts.adj.com



IMPORTANT NOTICE!

THERE ARE NO USER SERVICEABLE PARTS INSIDE THIS UNIT.

DO NOT ATTEMPT ANY REPAIRS YOURSELF; DOING SO WILL VOID YOUR MANUFACTURER'S WARRANTY. DAMAGES RESULTING FROM MODIFICATIONS TO THIS FIXTURE AND/OR THE DISREGARD OF SAFETY INSTRUCTIONS AND GUIDELINES IN THIS MANUAL VOID THE MANUFACTURER'S WARRANTY AND ARE NOT SUBJECT TO WARRANTY CLAIMS AND/OR REPAIRS.

It is strongly recommended to power the fixture down completely when not in use. Doing so will reduce wear on the fixture due to sustained or extended operational periods, thereby maximizing its operational lifespan.

KEY FEATURES

- Battery power
- Wireless DMX control
- RGBAW+UV 6-in-1 LEDs
- IP54 rating
- Indoor or outdoor usage

INCLUDED ITEMS:

- Charging base (x1)
- Power adapter (x1)
- UC-IR24 remote (x1)

WARRANTY REGISTRATION

Please fill out the enclosed warranty card to validate your purchase. All returned service items, whether under warranty or not, must be freight pre-paid and accompanied by a return authorization (R.A.) number. The R.A. number must be clearly written on the outside of the return package. A brief description of the problem as well as the R.A. number must also be written down on a piece of paper included in the shipping carton. If the unit is under warranty, you must provide a copy of your proof of purchase invoice. You may obtain an R.A. number by contacting our customer support team on our customer support number. All packages returned to the service department not displaying an R.A. number on the outside of the package will be returned to the shipper.

LIMITED WARRANTY (USA ONLY)

- A. ADJ Products, LLC hereby warrants, to the original purchaser, ADJ Products, LLC products to be free of manufacturing defects in material and workmanship for a prescribed period from the date of purchase (see specific warranty period on reverse). This warranty shall be valid only if the product is purchased within the United States of America, including possessions and territories. It is the owner's responsibility to establish the date and place of purchase by acceptable evidence, at the time service is sought.
- B. For warranty service, you must obtain a Return Authorization number (RA#) before sending back the product-please contact ADJ Products, LLC Service Department at 800-322-6337. Send the product only to the ADJ Products, LLC factory. All shipping charges must be pre-paid. If the requested repairs or service (including parts replacement) are within the terms of this warranty, ADJ Products, LLC will pay return shipping charges only to a designated point within the United States. If the entire instrument is sent, it must be shipped in its original package. No accessories should be shipped with the product. If any accessories are shipped with the product, ADJ Products, LLC shall have no liability whatsoever for loss of or damage to any such accessories, or for the safe return thereof.
- C. This warranty is void if the serial number has been altered or removed; if the product is modified in any manner which ADJ Products, LLC concludes, after inspection, affects the reliability of the product, if the product has been repaired or service by anyone other than ADJ Products, LLC factory unless prior written authorization was issued to purchaser by ADJ Products, LLC; if the product is damaged because not properly maintained as set forth in the instruction manual.
- D. This is not a service contract, and this warranty does not include maintenance, cleaning or periodic check up. During the period specified above, ADJ Products, LLC will replace defective parts at its expense with new or refurbished parts, and will absorb all expenses for warranty service and repair labor by reason of defects in material or workmanship. The sole responsibility of ADJ Products, LLC under this warranty shall be limited to the repair of the product, or replacement thereof, including parts, at the sole discretion of ADJ Products, LLC. All products covered by this warranty were manufactured after August 15, 2012, and bear identifying marks to that effect.
- E. ADJ Products, LLC reserves the right to make changes in design and/or improvements upon its products without any obligation to include these changes in any products theretofore manufactured.
- F. No warranty, whether expressed or implied, is given or made with respect to any accessory supplied with products described above. Except to the extent prohibited by applicable law, all implied warranties made by ADJ Products, LLC in connection with this product, including warranties of merchantability or fitness, are limited in duration to the warranty period set forth above. And no warranties, whether expressed or implied, including warranties of merchantability or fitness, shall apply to this product after said period has expired. The consumer's and/or Dealer's sole remedy shall be such repair or replacement as is expressly provided above; and under no circumstances shall ADJ Products, LLC be liable for any loss or damage, direct or consequential, arising out of the use of, or inability to use, this product.
- G. This warranty is the only written warranty applicable to ADJ Products, LLC Products and supersedes all prior warranties and written descriptions of warranty terms and conditions heretofore published.

LIMITED WARRANTY PERIODS

- **Non L.E.D. Lighting Products = 1-year (365 days) Limited Warranty** (Such as: Special Effect Lighting, Intelligent Lighting, UV lighting, Strobes, Fog Machines, Bubble Machines, Mirror Balls, Par Cans, Trussing, Lighting Stands etc. excluding LED and lamps)
- **Laser Products = 1 Year (365 Days) Limited Warranty** (excludes laser diodes which have 6 month limited warranty)
- **L.E.D. Products = 2-year (730 days) Limited Warranty** (excluding batteries which have a 180 day limited warranty)
Note: 2 Year Warranty only applies to purchases within the United States.
- **StarTec Series = 1 Year Limited Warranty** (excluding batteries which have a 180 day limited warranty)
- **ADJ DMX Controllers = 2 Year (730 Days) Limited Warranty**

SAFETY GUIDELINES

For Your Own Personal Safety, Please Read and Understand This Manual Completely Before You Attempt To Install Or Operate This Unit!

This fixture is a sophisticated piece of electronic equipment. To guarantee smooth operation, it is important to follow all instructions and guidelines in this manual. ADJ Products, LLC is not responsible for injury and/or damages resulting from the misuse of this fixture due to the disregard of the information printed in this manual. Only qualified and/or certified personnel should perform installation of this fixture, and only the original rigging parts included with this fixture should be used for installation. Any modifications to the fixture and/or the included mounting hardware will void the original manufacturer's warranty and increase the risk of damage and/or personal injury.



PROTECTION CLASS 1 - FIXTURE MUST BE PROPERLY GROUNDED



THERE ARE NO USER SERVICEABLE PARTS INSIDE THIS UNIT. DO NOT ATTEMPT ANY REPAIRS YOURSELF; DOING SO WILL VOID YOUR MANUFACTURER'S WARRANTY. DAMAGES RESULTING FROM MODIFICATIONS TO THIS FIXTURE AND/OR THE DISREGARD OF SAFETY INSTRUCTIONS AND GUIDELINES IN THIS MANUAL VOID THE MANUFACTURER'S WARRANTY AND ARE NOT SUBJECT TO ANY WARRANTY CLAIMS AND/OR REPAIRS.



**DO NOT PLUG FIXTURE INTO A DIMMER PACK!
NEVER OPEN THIS FIXTURE WHILE IN USE!
UNPLUG POWER BEFORE SERVICING FIXTURE!
MAXIMUM AMBIENT OPERATING TEMPERATURE IS 104°F (40°C)!
NEVER TOUCH FIXTURE WITH BARE HANDS DURING OPERATION, AS SURFACE TEMPERATURE DURING OPERATION MAY REACH 167°F (75°C)!
KEEP FLAMMABLE MATERIALS AWAY FROM FIXTURE!**

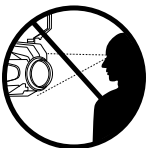

**NEVER LOOK DIRECTLY INTO THE LIGHT SOURCE!
RETINA INJURY RISK - MAY INDUCE BLINDNESS!
SENSITIVE PERSONS MAY SUFFER AN EPILEPTIC SHOCK!**



**APPLIES TO LIGHTING FIXTURE ONLY! CHARGING COMPONENTS ARE NOT IP RATED AT ALL!
INGRESS OF DUST INTO FIXTURE IS NOT ENTIRELY PREVENTED, BUT WILL NOT ENTER IN SUFFICIENT QUANTITY TO INTERFERE WITH OPERATION OF DEVICE.
FIXTURE PROTECTED AGAINST WATER SPLASHES FROM ANY DIRECTION.**

SAFETY GUIDELINES

! CAUTION

HIGH INTENSITY ULTRAVIOLET LIGHT



**AVOID DIRECT EYE & SKIN EXPOSURE.
WEAR PROPER EYE & SKIN PROTECTION.
SEE MANUAL FOR SAFETY INSTRUCTIONS.**

- **RISK GROUP 3 - RISK OF EXPOSURE TO ULTRAVIOLET (UV) RADIATION!**
- **FIXTURE EMITS HIGH INTENSITY WAVELENGTH OF ULTRAVIOLET LIGHT.**
- **WEAR PROPER EYE AND SKIN PROTECTION.**
- **DO NOT OPERATE FIXTURE WITH DAMAGED/MISSING EXTERNAL COVER OR PROTECTIVE LENS.**
- **DO NOT LOOK DIRECTLY INTO THE (UV) LIGHT AND/OR VIEW (UV) LIGHT DIRECTLY WITH OPTICAL INSTRUMENTS THAT MAY CONCENTRATE THE LIGHT/RADIATION OUTPUT.**
- **AVOID PROLONGED PERIODS OF EXPOSURE.**
- **AVOID WEARING WHITE COLOR CLOTHING AND/OR USING (UV) PAINTS ON SKIN.**
- **AVOID DIRECT EYE AND/OR SKIN EXPOSURE AT DISTANCES SHORTER THAN 11 FEET (3.3 METERS).**
- **INDIVIDUALS SUFFERING FROM A RANGE OF EYE CONDITIONS, SUNLIGHT EXPOSURE DISORDERS, OR INDIVIDUALS USING PHOTSENSITIVE MEDICATION MAY EXPERIENCE DISCOMFORT IF EXPOSED TO THE ULTRAVIOLET (UV) LIGHT EMITTED FROM THIS FIXTURE.**
- Be sure to save the packing carton in the unlikely event the device has to be returned for service.
- Do not spill water or other liquids into or on to the fixture, charging system, or IR remote.
- Be sure that the voltage of the power source matches the required voltage for the device.
- Do not open up the device for any reason. There are no user serviceable parts inside.
- Disconnect the device's main power when left unused for long periods of time.
- Never connect this device to a dimmer pack.
- Do not attempt to operate this device if it has been damaged in any way.
- Never operate this device with the cover removed.
- To reduce the risk of electrical shock or fire, do not expose the charging system, IR remote, or fixture to rain or moisture.
- Do not attempt to operate this device if the power cord has been frayed or broken.
- Do not attempt to remove or break off the ground prong from the electrical cord. This prong is used to reduce the risk of electrical shock and fire in the event of an internal short.
- Disconnect from main power before making any type of connection.
- Never block the ventilation holes. Always be sure to mount this device in an area that will allow proper ventilation. Allow about 6" (15cm) between this device and a wall.
- The charging system and fixture are intended for indoor use only. Use of these devices outdoors voids all warranties.
- Always mount this unit in a safe and stable matter.
- Please route your power cord out of the way of foot traffic. Power cords should be routed so they are not likely to be walked on, or pinched by items placed upon or against them.

Maximum operating temperature for this fixture is 113 degrees F (45 degrees C). Do not operate this device when ambient temperature exceeds this value!

Keep flammable materials away from this fixture!

CHARGING DEVICES AND FIXTURE ARE DESIGNED FOR INDOOR USE ONLY! DO NOT EXPOSE TO RAIN OR MOISTURE!

The device should be serviced by qualified service personnel when:

- A. The power-supply cord or the plug has been damaged.
- B. Objects have fallen on, or liquid has been spilled into, the device.
- C. The charging devices or fixture have been exposed to rain or water.
- D. The appliance does not appear to operate normally or exhibits a marked change in performance.

OVERVIEW

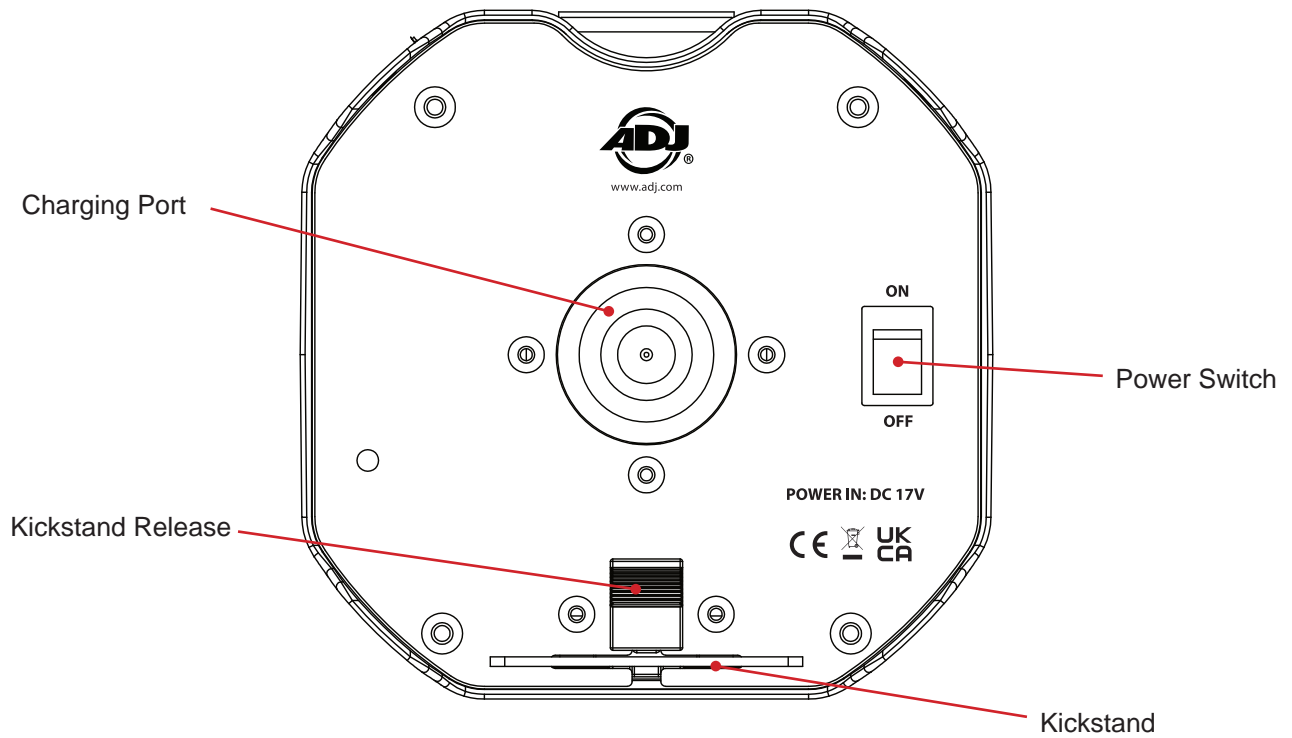
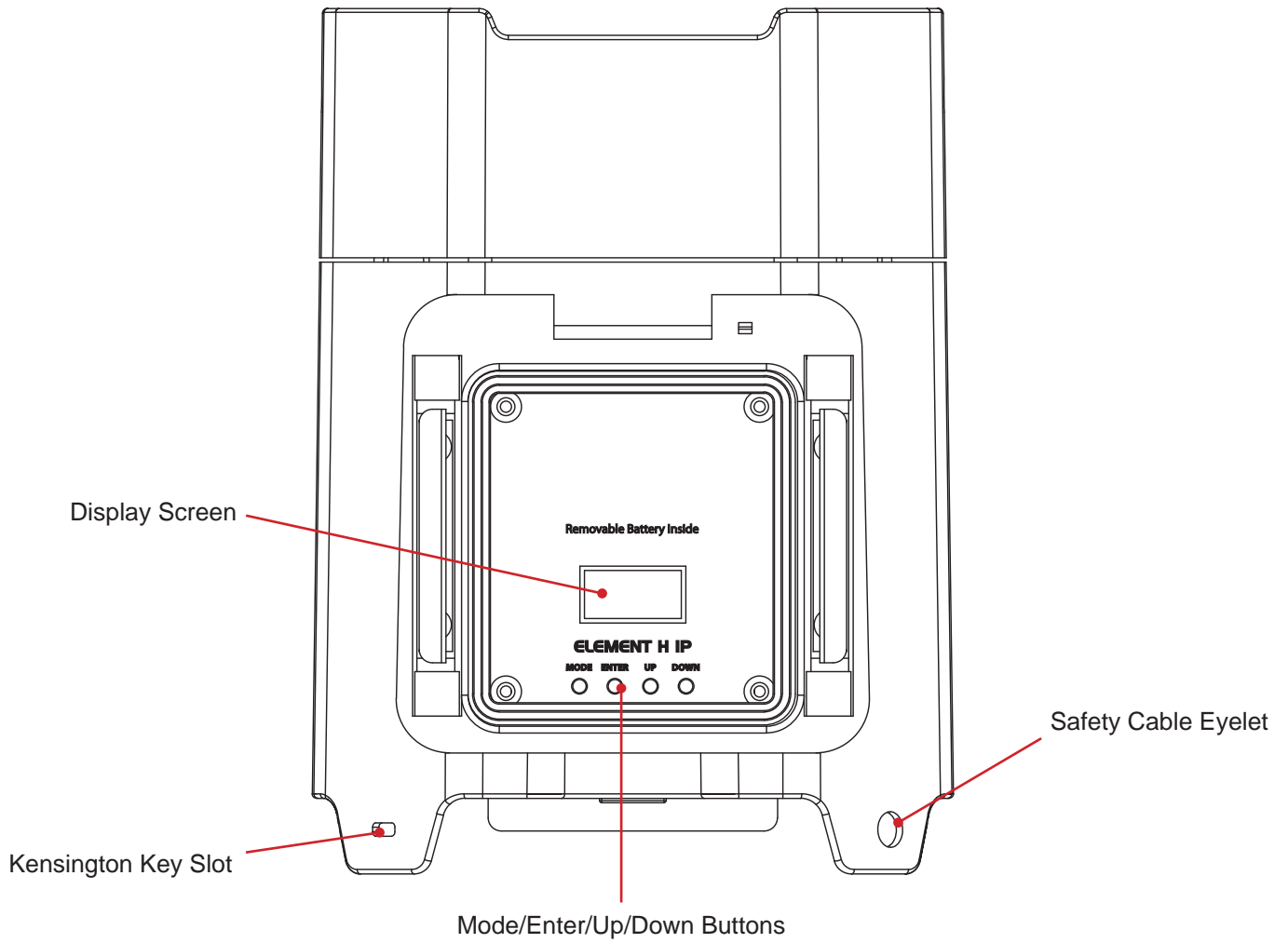

WIRELESS SETUP

This device does not feature physical DMX connector ports. Therefore, in order to utilize DMX control, the user must first set up the device to run wireless DMX control. Follow the directions below to configure wireless DMX control:

1. First, select the DMX Channel Mode for that you would like the device to operate in. Press MODE until the the “DMX Settings” menu is displayed on the screen. Use the UP or DOWN buttons to scroll to “DMX Channel Mode,” then press the SETUP button.
2. Use UP or DOWN to scroll through the DMX Channel Mode options, then press SETUP to con-firm your selection.
3. Next, enable the device’s Wireless capability. Press MODE until the “Personality” menu is displayed on the screen, then use UP or DOWN to scroll to “Wireless Settings” and press SETUP.
4. Use UP or DOWN to scroll to “Enable Wireless,” then press SETUP to select this option.
5. Use UP or DOWN once again to toggle this setting to “Yes,” then confirm by pressing SETUP.
6. Next, select the Wireless channel. Press MODE until the “Personality” menu is displayed on the screen again, then use UP or DOWN to scroll to “Wireless Settings” and press SETUP.
7. Use UP or DOWN to scroll to “Set Wireless Channel,” then press SETUP again.
8. Now use UP or DOWN to scroll to your desired Wireless channel. Selectable values range from 00 to 14.
9. Finally, set the DMX address. Press the MODE button until the “DMX Settings” menu is displayed on the screen, then use UP or DOWN to scroll to “DMX Address,” then press SETUP.
10. Use the UP or DOWN buttons to scroll to your desired DMX address, then press SETUP to confirm your selection. Available values range from 001 to 512. Refer to the DMX Addressing section of this manual for detailed guidance. Repeat these steps for each individual unit that you wish to use.

There are many factors that can affect and/or interrupt a wireless signal, including walls, glass, metal, objects, and people. Therefore, the following guidelines are recommended in order to maximize the chances of having a clear path for the wireless signal to reach the device:

- Install the device a minimum of 9.8 ft (3m) above audiences and/or ground level.
- Arrange the wireless antenna in an upright, vertical position.
- Position devices in direct line of sight of the transmitting controller.

Careful planning and testing of the selected installation location is critical to ensure optimum and reliable wireless operation.

**9.8 ft (3m)
Above Ground**

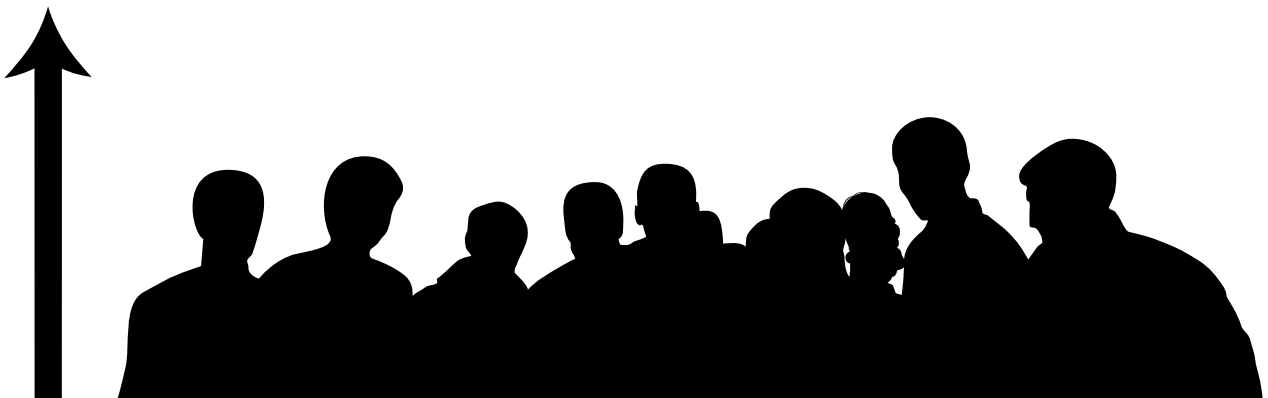

IR REMOTE CONTROL

This unit can be operated using the ADJ UC IR24 remote control. **The unit can only be controlled when it has been set to Primary mode. The unit will NOT respond to commands when it has been set to Secondary mode.** When using the UC IR to control multiple units that are operating in primary/secondary mode, follow these steps to set up the units:

1. Power on the unit, and press MODE to scroll to the “Personality” menu, then press ENTER.
2. Use the UP and DOWN buttons to scroll to “Prim/Sec Mode”. Press ENTER, then use the UP and DOWN buttons to toggle between “Primary” and “Secondary”.
3. Press ENTER to confirm and return to the “Personality” menu.
4. Use UP and DOWN to scroll to “Wireless Settings” and press ENTER.
5. Use the UP and DOWN buttons select “Set Wireless Channel.” Press ENTER and use UP and DOWN to set the unit to your desired Wireless channel. Repeat these steps for each unit. Please note that all units should be set to the same Wireless channel.

NOTES:

- Only one unit should be configured as the primary, while all the other units should be configured as secondaries.
- All units in the system should be set to the same Wireless channel. If all units are set to the same Wireless channel, and the units do not sync up and/or respond to commands, try using a different Wireless channel.
- All units should be set to the same DMX channel mode.
- If fixtures fail to sync, verify that all settings mentioned above are the same, then power all devices off, then switch them on again to re-establish the link.

CONTROLS

- **ON and OFF:** When the ON button is pressed, the lighting fixture shall return to its last running state. When the OFF button is pressed, the unit shall go into stand by mode in a blackout state.
- **STROBE:** The unit shall strobe the selected color or program. The strobe rate can be adjusted with the + / - buttons. Buttons 0-15 are used to select the color.
- **SOUND:** Triggers the selected program steps based on sound input. The microphone sensitivity can then be adjusted with the +/- buttons.
- **COLOR:** When the color button is pressed, preset static colors can be selected using buttons 0-15. The intensity for the set color can be adjusted with the +/- buttons.
- **PROGRAM:** When the program button is pressed, internal programs can be selected by pressing buttons 0-15. The selected program’s speed can be adjusted with the +/- buttons.
- **+ and - buttons:** These buttons are used to adjust strobe rate, mic sensitivity, brightness intensity, or program run speed, depending on which mode is active. Single-level adjustments can be made with individual buttons presses, while large adjustments can quickly be made by press-ing and holding.
- **0-15 buttons:** These buttons are used to select preset static colors or internal programs, depending on which mode is active. Colors stored in buttons 0-15 can be edited from the units menu if desired.



INSTALLATION

IP RATING

The ELEMENT H IP is **IP54** rated. Ingress of dust is not entirely prevented, but it will not enter in sufficient quantity to interfere with satisfactory operation of the device. The ELEMENT H IP is also protected against splashing water from any direction. **WHILE SOME DEGREE OF WATER RESISTANCE IS PRESENT, THE ELEMENT H IP FIXTURE IS NOT INTENDED FOR OUTDOOR USE. Please note that the charging components are not IP-rated at all, and are intended for use in dry, indoor conditions only.**

FLAMMABLE MATERIAL WARNING!

Keep device a minimum of 5.0 feet (1.5m) away from flammable material and/or pyrotechnics.

ELECTRICAL CONNECTIONS

A qualified electrician should be used for all electrical connections and/or installations.

DO NOT INSTALL THE DEVICE IF YOU ARE NOT QUALIFIED TO DO SO!

The unit **MUST** be installed following all local, national, and country commercial electrical and construction codes and regulations.

Before installing or mounting any device, a professional equipment installer **MUST** be consulted to determine whether the mounting structure or surface is properly certified to safely support the combined weight of the fixture, clamps, cables, and accessories.

Maximum operating temperature **113 degrees F (45 degrees C)**. Do not operate the device if ambient temperatures exceeds this value.

This fixture should be installed away from walking paths, seating areas, and areas where unauthorized personnel might be able to reach the device by hand.

NEVER stand directly below the fixture when rigging, removing, or servicing.

Allow approximately 15 minutes for the fixture to cool down before servicing.

INSTALLATION

CLAMP INSTALLATION

The Element H IP features a mounting clamp attachment point on the side of the device, as well as an eyelet for safety cable at the bottom of one foot (see the illustration below). When mounting the fixture to a truss or any other suspended or overhead installation, be sure to secure appropriately rated clamps (not included) to the clamp attachment point, as well as an appropriately rated safety clamp.

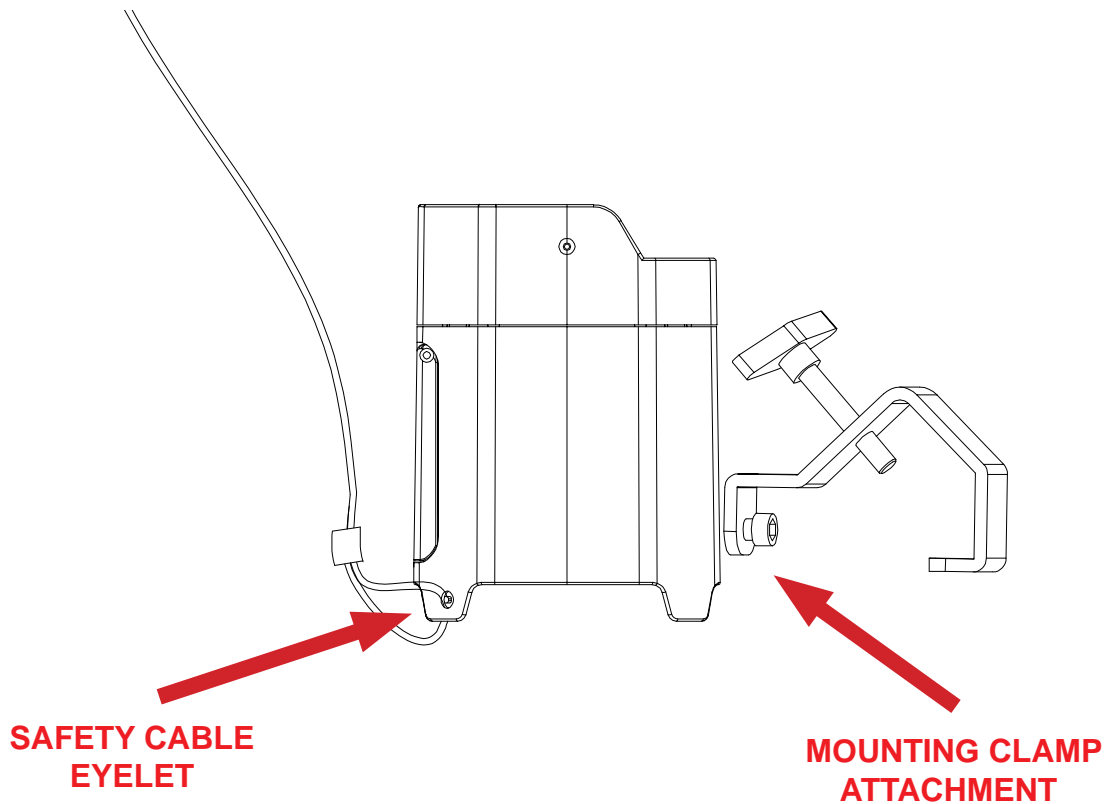

**SAFETY CABLE:
ALWAYS ATTACH A SAFETY CABLE WHENEVER INSTALLING THIS FIX-
TURE IN A SUSPENDED ENVIRONMENT TO ENSURE THAT THE FIXTURE
WILL NOT FALL IF THE CLAMP FAILS.**

RIGGING

Overhead rigging requires extensive experience, including but not limited to: calculating working load limits, understanding the installation material being used, and periodic safety inspection of all installation material and the fixture itself. If you lack these qualifications, do not attempt to perform the installation yourself. Improper installation can result in bodily injury.

INSTALLATION

KICKSTAND FOR FLOOR PLACEMENT

The Element H IP can also be placed on the floor to provide an uplighting display, and features a retractable kickstand that allows the device to be angled in the direction of the desired display.

To deploy the kickstand, simply toggle the switch on the underside of the device, near the power charging port (1). The kickstand can then be deployed from the underside (2) at various notched increments, allowing a maximum angle of 65-90 degrees from the vertical axis (3).

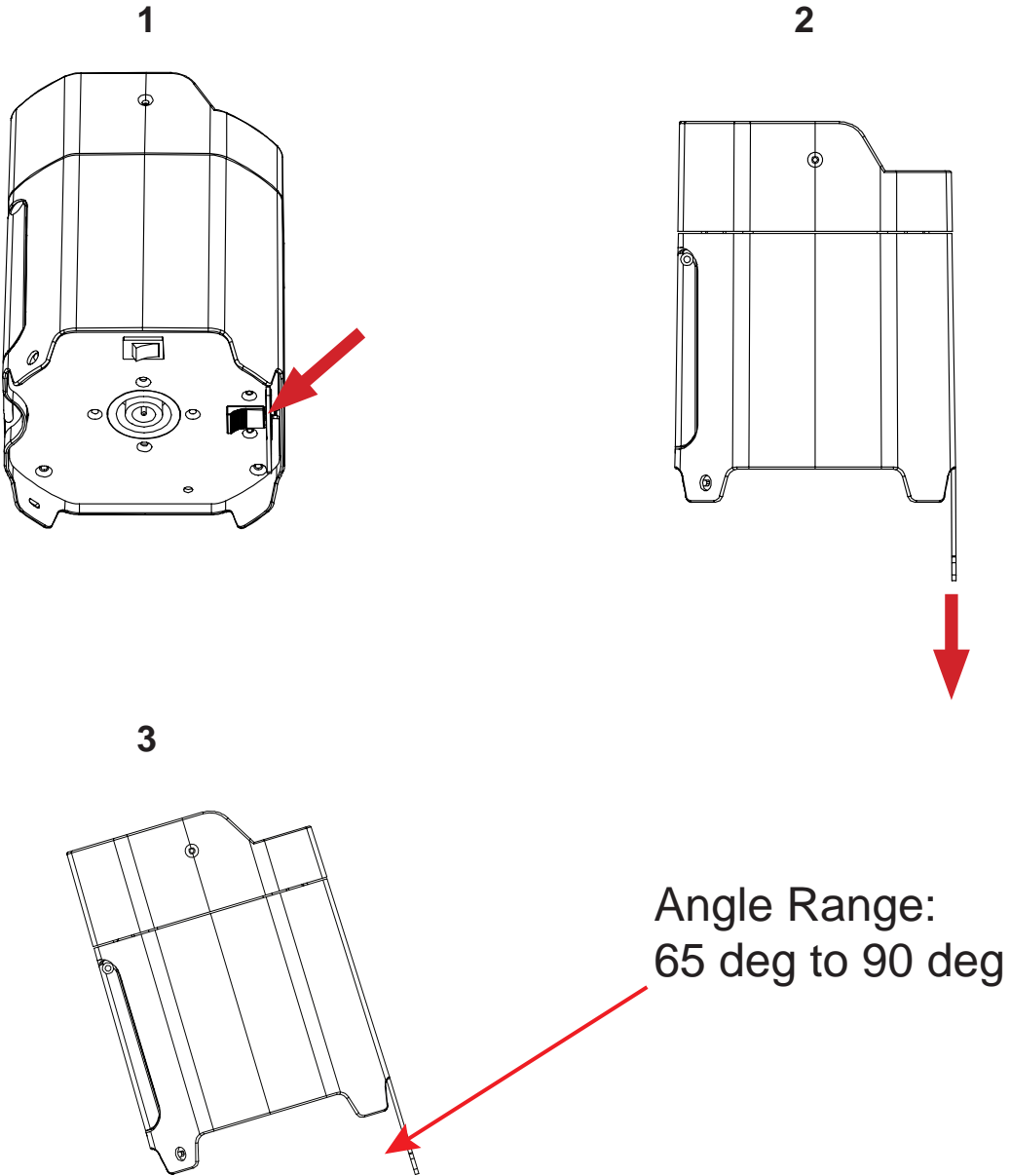

INSTALLATION

KENSINGTON KEY SLOT

The device features a slot for a Kensington-type security device that can be used to prevent theft. The key slot is located near the bottom of one of the device's feet, as shown in the illustration below. Be sure to attach the security device to a sturdy, fixed anchor point.

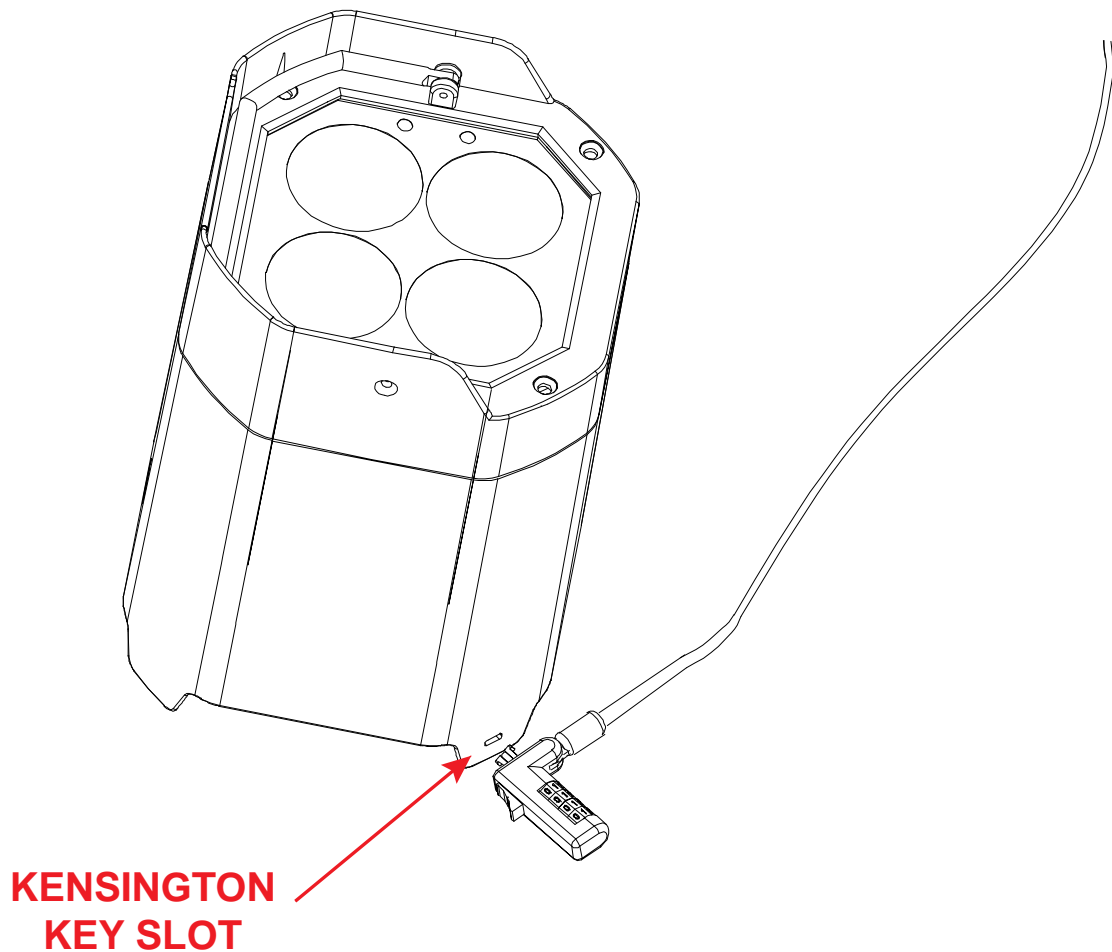

BATTERY: CHARGING

The fixture may be charged using the included charging base and power supply. Connect the power supply to a power source on one end, and to the charging base on the other, then slot the fixture onto the charging base with the charging port side facing downwards. Refer to the image below.

It is recommended to disconnect the unit from the charger once the battery has reached full charge. Doing so reduces the risk of overcharging the battery, which can shorten the service life of the battery.

Please note that the charging components are NOT protected against the intrusion of dust and/or water, and are intended for use only in a dry indoor environment Do NOT expose to rain or moisture.

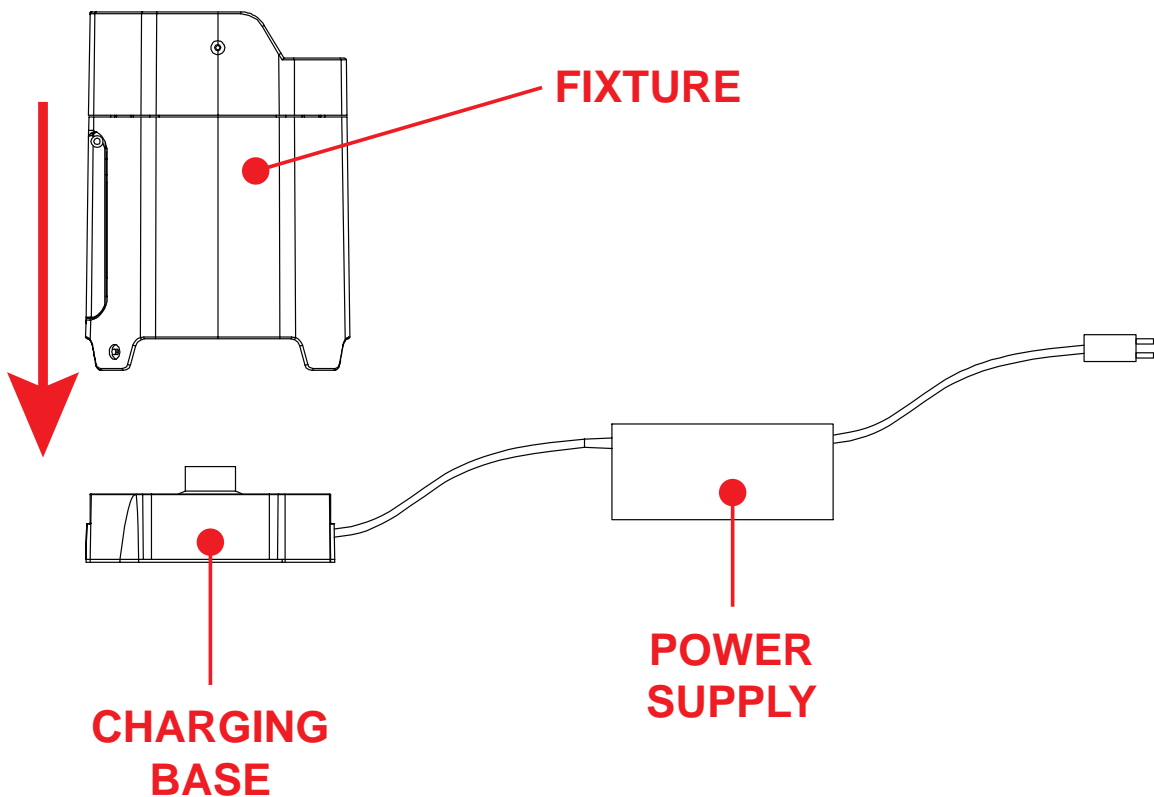

BATTERY: REPLACEMENT



1. Power the unit down and disconnect from power. Lift the cover panel on the side of the unit, exposing the panel with the control screen. Use a screwdriver to remove the four screws at the corners of the display screen panel.

2. Carefully lift the display screen panel up and away from the body of the fixture, making sure not to damage any of the cables connected to the back of the panel or the gasket fitted around the edge of the panel.

BATTERY: REPLACEMENT



3. With the display screen panel removed, the blue colored battery should be plainly visible. Locate the two white wires that run from the battery and link to a red wire and a black wire via a small white connector. Disconnect the connector, then remove the battery and replace with a new unit.

4. Reassemble the device by re-connecting the wire connector, then placing the display screen panel back in place. Please make sure that the gasket is fully seated around the edge of the panel. Replace the panel screws, and torque to **3.6 lb-in (4.2 kg-cm)**.

BATTERY: GENERAL INFORMATION

HANDLING PRECAUTIONS

Do not short circuit the battery. Avoid subjecting the battery to a short circuit, as doing so generates a very high current, resulting in overheating, electrolyte gel leakage, harmful fumes, explosion risk, or other damage to the battery.

Mechanical shock. Dropping, impacting, striking, or bending the unit, or subjecting the unit to any other types of mechanical shock may cause failure or shorten life of the battery.

Do not disassemble the batteries. Never disassemble the batteries, as doing so may result in an internal short circuit in the battery, leading to fire, explosion, release of harmful fumes, or other hazards. Electrolyte gel is harmful, and contact should be avoided whenever possible. Should the electrolyte gel come into contact with the skin or eyes, flush the area of contact immediately with fresh water and seek medical attention immediately.

Do not expose battery to heat or fire. Never incinerate or dispose of the batteries in fire, as this could result in an explosion.

Do not expose the battery to water or liquids. Never expose or immerse the batteries in liquids of any type, including water, seawater, soft drinks, juices, coffee, or other beverages.

Battery Replacement. For battery replacement please contact customer support.

Never use a damaged battery. Shipping carries a risk of damage to the battery. Should damage be observed, including damage to the plastic casing of the battery, deformation of the battery package, chemical or electrolyte odor, or leakage of the electrolyte gel, or any other miscellaneous damage, **DO NOT use the battery.** A battery with a odor of electrolyte or a gel leakage should be placed away from fire to avoid risk of fire or explosion.

Battery Storage. The battery should be stored at room temperature, with a charge of at least 50%. During long periods of storage, it is recommended that the battery be charged every 6 months. Doing so will prolong the life of the battery and will also make sure that the battery charge does not fall below the 30% mark.

Other Chemical Reactions. Because batteries rely on a chemical reaction to work, battery performance will deteriorate over time, even if stored for a long period of time without being used. In addition, if various usage conditions (such as charge, discharge, ambient temperature, etc.) are not maintained within the specified ranges, the life expectancy of the battery maybe shortened or the device in which the battery is used may be damaged by electrolyte gel leakage. If the batteries cannot maintain a charge for long periods of time, even when they are charged correctly, this may indicate the need to replace the battery.

Battery Disposal. Please dispose of battery according to local regulations.

SYSTEM MENU

This fixture includes an easy to navigate control panel display, from which all necessary settings and adjustments can be made. Press the **MODE** button to scroll through the main menu options, then press **ENTER** to select the currently displayed option. Then use the **UP** and **DOWN** buttons to scroll through the sub-menu options until reaching the desired setting. Press the **MODE** button at any time to return to the main menu without making any adjustments.

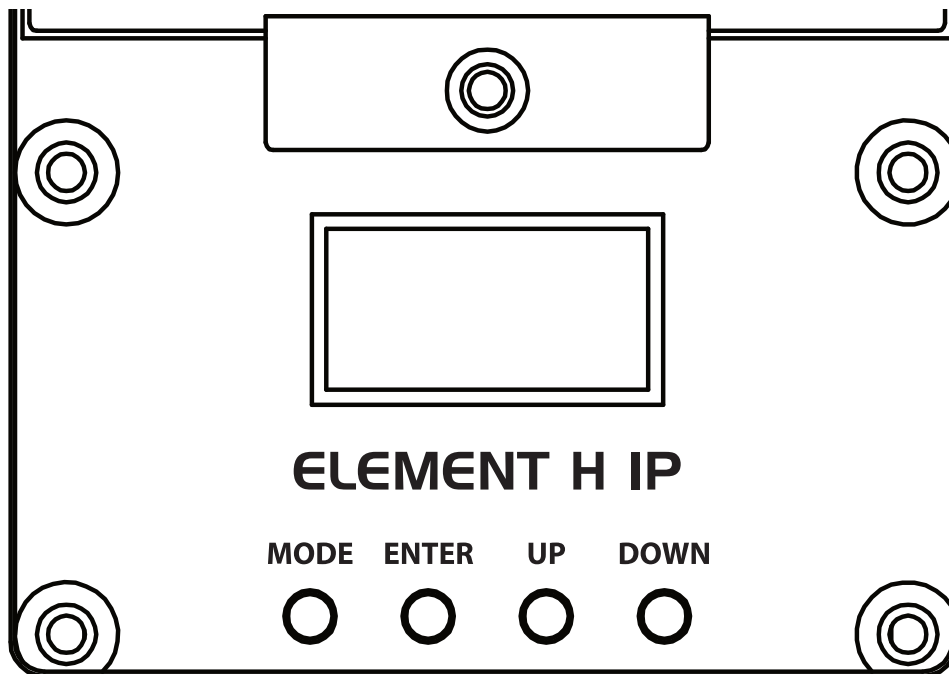

SYSTEM MENU

DMX SETTINGS	DMX Address	001 - 512		Set the starting DMX address of the device	
	DMX Channel Mode	6ch		Set the DMX mode	
		8ch			
		9ch			
		12ch			
		14ch			
		15ch			
	No DMX Address	17ch		Device holds last received channel values in the event that DMX signal is lost or interrupted	
		Hold Last			
		Blackout			All channels go to 0 when DMX signal is lost or interrupted
Manual Settings		All channels go to the last manual settings received when DMX signal is lost or interrupted			
		Internal Programs		Unit default to the designated internal program when DMX signal is lost or interrupted	
PERSONALITY	Prim/Sec Mode	Primary / Secondary			
	Wireless Settings	Enable Wireless	On / Off		
		Set Wireless Channel	00 - 15		
	IR Remote On/Off	On / Off			
	Dim Modes	Standard			
		Stage			
		TV			
		Architectural			
		Theatre			
		Stage 2			
		Dim Delay	0 - 99		
	Dim Curve	Square			
		Linear			
Inv. Squa					
S Curve					

SYSTEM MENU

PERSONALITY (continued)	Display	Screen Saver Delay	Off, 1sec - 10sec		Time before display goes to sleep; "Off" keeps screen on at all times
		Touch Screen Lock	Off		
			30sec		
			1min		
		Rotate Display 180	Yes / No		
	Language	Passcode = 050	English / Spanish		
	IR Button Colors	Button 0	Red	000 - 255	Refer to IR Default Values section of this manual for detailed info
			Green	000 - 255	
			Blue	000 - 255	
			White	000 - 255	
			Amber	000 - 255	
			UV	000 - 255	
		Button 1	Red	000 - 255	
			Green	000 - 255	
			Blue	000 - 255	
			White	000 - 255	
			Amber	000 - 255	
			UV	000 - 255	
		
		Button 15	Red	000 - 255	
Green			000 - 255		
Blue			000 - 255		
White			000 - 255		
Amber			000 - 255		
UV	000 - 255				
Service	Passcode = 011	Factory Restore	Yes / No	Returns unit to default factory settings	
MANUAL CONTROL	Red	000 - 255			
	Green	000 - 255			
	Blue	000 - 255			
	White	000 - 255			
	Amber	000 - 255			
	UV	000 - 255			
	Color Macros	000 - 255			
	Color Temp Linear	000 - 255			
	Color Temp Presets	000 - 255			
	Strobe	000 - 255			
	Master Dimmer	000 - 255			

SYSTEM MENU

INTERNAL PROGRAMS	Program 0	Speed	1 - 255	1 is slowest, 255 is fastest
		Fade	0 - 255	0 disables fade, 255 is fastest
	Program 1	Speed	1 - 255	1 is slowest, 255 is fastest
		Fade	0 - 255	0 disables fade, 255 is fastest

	Program 13	Speed	1 - 255	1 is slowest, 255 is fastest
Fade		0 - 255	0 disables fade, 255 is fastest	
INFORMATION	LED Temperature	xxx F / xxx C		Displays current device temperature
	Software Version	x.xx		Displays current software version
BATTERY	Charging Time	xx hours		Time remaining until fully charged
	Current Life	xxx %		Battery life remaining (% of full charge)
	Operation Mode	Standard 6		6 hour battery life (approximate)
		Saver 12		12 hour battery life (approximate)

DMX ADDRESSING

All fixtures should be given a DMX starting address when operating with a DMX controller, in order to ensure that the correct fixture responds to the correct control signal. This digital starting address is the channel number from which the fixture starts to “listen” to the digital control signal sent out from the DMX controller. This starting DMX address is assigned by setting the correct DMX address on the digital control display on the fixture.

You can set the same starting address for all fixtures or a group of fixtures, or set different addresses for each individual fixture. Setting all fixtures to the same DMX address will cause all fixtures to react in the same way. In this case, please note that changing the settings of one channel will affect all the fixtures simultaneously.

If you set each fixture to a different DMX address, each unit will start to “listen” to the channel number you have set, based on the quantity of DMX channels of each fixture. That means changing the settings of one channel will only affect the selected fixture.

As an example, when operating this fixture model in 6 channel mode, you should set the starting DMX address of the first unit to 1, the second unit to 7 (1 + 6), the third unit to 13 (1 + 6 + 6), and so on. Refer to the chart below for more details.

Channel Mode	Unit 1 Addr	Unit 2 Addr	Unit 3 Addr	Unit 4 Addr
6-Ch	1	7	13	19
8-Ch	1	9	17	25
9-Ch	1	10	19	28
12-Ch	1	13	25	37
14-Ch	1	15	29	43
15-Ch	1	16	31	46
17-Ch	1	18	35	52

DMX TRAITS

CHANNEL							DMX VALUES	FUNCTION
6CH	8CH	9CH	12CH	14CH	15CH	17CH		
1	1	1	1	1	1	1	000 - 255	All Red , 0% - 100%
2	2	2	2	2	2	2	000 - 255	All Green , 0% - 100%
3	3	3	3	3	3	3	000 - 255	All Blue , 0% - 100%
4	4	4	4	4	4	4	000 - 255	All White , 0% - 100%
5	5	5	5	5	5	5	000 - 255	All Amber , 0% - 100%
6	6	6	6	6	6	6	000 - 255	All UV , 0% - 100%
			7		7	7	000 - 255	Color Macros , see Color Macros Chart section of this manual
			8		8	8	000 - 255	Color Temperature , 2300K - 9900K Linear
			9		9	9		White Color Temperature Presets
				000 - 022			Open	
				023 - 099			Presets, see White Color Temperature Preset Chart section of this manual	
				100 - 255			No Function	
	7	7	10	7	10	10		Shutter, Strobe
							000 - 031	LEDs Off
							032 - 063	LEDs On
							064 - 095	Strobe Effect, slow to fast
							096 - 127	LEDs On
							128 - 159	Pulse Effect in Sequences
							160 - 191	LEDs On
							192 - 223	Random Strobe Effect, slow to fast
							224 - 255	LEDs On
	8	8	11	8	11	11	000 - 255	Dimmer Intensity , 0% to 100%
		9	12	9	12	12	000 - 255	Dimmer Fine
			10	13	13	13		Auto Programs
							000 - 010	Off
							011 - 026	Auto Program 1
							026 - 043	Auto Program 2
							044 - 060	Auto Program 3
							061 - 076	Auto Program 4
							077 - 093	Auto Program 5
							094 - 110	Auto Program 6
							111 - 126	Auto Program 7
							127 - 143	Auto Program 8
							144 - 160	Auto Program 9
							161 - 176	Auto Program 10
			177 - 193	Auto Program 11				

DMX TRAITS

CHANNEL							DMX VALUES	FUNCTION
6CH	8CH	9CH	12CH	14CH	15CH	17CH		
				10	13	13		Auto Programs (continued)
							194 - 210	Auto Program 12
							211 - 226	Auto Program 13
							227 - 255	No Function
				11	14	14	000 - 255	Auto Programs Speed , slow to fast
				12	15	15	000 - 255	Auto Programs Fade , least to most
								Dim Mode
							000 - 020	Default to Unit Setting
							021 - 040	Standard
							041 - 060	Stage
							061 - 080	TV
							081 - 100	Architectural
							101 - 120	Theatre
							121 - 140	Stage 2
								Dim Speed
							141	0.1s
							142	0.2s
							143	0.3s
							144	0.4s
							145	0.5s
							146	0.6s
							147	0.7s
							148	0.8s
							149	0.9s
							150	1.0s
							151	1.5s
							152	2.0s
							153	3.0s
							154	4.0s
							155	5.0s
							156	6.0s
							157	7.0s
							158	8.0s
							159	9.0s
							160	10.0s
							161 - 255	Default to Unit Setting
								Dim Curves
							000 - 020	Square
							021 - 040	Linear
							041 - 060	Inv. Squa.
							061 - 080	S. Curve
							081 - 255	No Function

IR DEFAULT VALUES

BUTTON	RED	GREEN	BLUE	WHITE	AMBER	UV
0	255	255	255	0	255	0
1	255	0	0	0	0	0
2	0	255	0	0	0	0
3	0	0	255	0	0	0
4	255	46	0	0	0	0
5	0	255	28	0	0	0
6	17	0	75	0	0	0
7	255	83	0	0	63	0
8	0	255	52	0	0	0
9	32	0	75	0	22	0
10	0	0	0	0	255	0
11	0	114	160	0	0	0
12	100	0	97	0	0	0
13	255	255	0	0	255	0
14	0	75	136	0	0	0
15	146	0	80	0	0	0

EDITING RGBA IR BUTTON VALUES

These fixtures allow the user to create custom RGBA values and assign them to the numbered keys (0-15) on the remote control. Follow the steps below:

In the main system menu, press MODE to navigate to “Personality,” then press ENTER. Use the UP and DOWN buttons to scroll to “IR Button Colors,” then press ENTER again.

1. Use the UP and DOWN buttons to scroll to the number of the remote button that you would like to use. Options range from “Button 0” to “Button 15.” Press ENTER to select the button shown on the display screen.
2. Create a custom color for the button you have selected by using the UP and DOWN buttons to scroll through the color component options (Red, Green, Blue, or Amber). Press ENTER to select a color component option, then use the UP and DOWN buttons to adjust the intensity of that color component option. Selectable values range from 000 to 255. Repeat this process until you have set the desired Red, Green, Blue, and Amber intensities to create your custom color.

NOTE: Once you have created and assigned a custom RGBA value to a remote button, the default color for the remote button will be overridden. This means that the output color of the fixture may no longer resemble the color shown on the remote button. The only way to return to the default RGBA value is to reset the unit to the default factory settings by navigating to Personality > Service > Factory Restore.

NOTE: If multiple units have been linked in a primary-secondary set up, the custom RGBA values only need to be set up on the primary unit. The custom RGBA settings will carry over automatically to any secondary units in the system.

COLOR MACROS

DMX VALUES	COLOR MACRO
0-3	Off
4-7	Red
8-11	Green
12-15	Blue
16-19	White
20-23	Amber
24-27	UV
28-31	R+G
32-35	R+B
36-39	R+W
40-43	R+A
44-47	R+UV
48-51	G+B
52-55	G+W
56-59	G+A
60-63	G+UV
64-67	B+W
68-71	B+A
72-75	B+UV
76-79	W+A
80-83	W+UV
84-87	A+UV
88-91	R+G+B
92-95	R+G+W
96-99	R+G+A
100-103	R+G+UV
104-107	R+B+W
108-111	R+B+A
112-115	R+B+UV
116-119	R+W+A
120-123	R+W+UV
124-127	R+A+UV
128-131	G+B+W
132-135	G+B+A
136-139	G+B+UV
140-143	G+W+A

DMX VALUES	COLOR MACRO
144-147	G+W+UV
148-151	G+A+UV
152-155	B+W+A
156-159	B+W+UV
160-163	B+A+UV
164-167	W+A+UV
168-171	R+G+B+W
172-175	R+G+B+A
176-179	R+G+B+UV
180-183	R+G+W+A
184-187	R+G+W+UV
188-191	R+G+A+UV
192-195	R+B+W+A
196-199	R+B+W+UV
200-203	R+B+A+UV
204-207	R+W+A+UV
208-211	G+B+W+A
212-215	G+B+W+UV
216-219	G+B+A+UV
220-223	G+W+A+UV
224-227	B+W+A+UV
228-231	R+G+B+W+A
232-235	R+G+B+W+UV
236-239	R+G+B+A+UV
240-243	R+G+W+A+UV
244-247	R+B+W+A+UV
248-251	G+B+W+A+UV
252-255	R+G+B+W+A+UV

WHITE COLOR TEMPERATURE PRESETS

Color Temp	DMX Value
No Function	000 - 022
2300	23
2400	24
2500	25
2600	26
2700	27
2800	28
2900	29
3000	30
3100	31
3200	32
3300	33
3400	34
3500	35
3600	36
3700	37
3800	38
3900	39
4000	40
4100	41
4200	42
4300	43
4400	44
4500	45
4600	46
4700	47
4800	48
4900	49
5000	50
5100	51
5200	52

Color Temp	DMX Value
5300	53
5400	54
5500	55
5600	56
5700	57
5800	58
5900	59
6000	60
6100	61
6200	62
6300	63
6400	64
6500	65
6600	66
6700	67
6800	68
6900	69
7000	70
7100	71
7200	72
7300	73
7400	74
7500	75
7600	76
7700	77
7800	78
7900	79
8000	80
8100	81
8200	82
8300	83

Color Temp	DMX Value
8400	84
8500	85
8600	86
8700	87
8800	88
8900	89
9000	90
9100	91
9200	92
9300	93
9400	94
9500	95
9600	96
9700	97
9800	98
9900	99

DIMMER CURVES AND DIMMER MODES

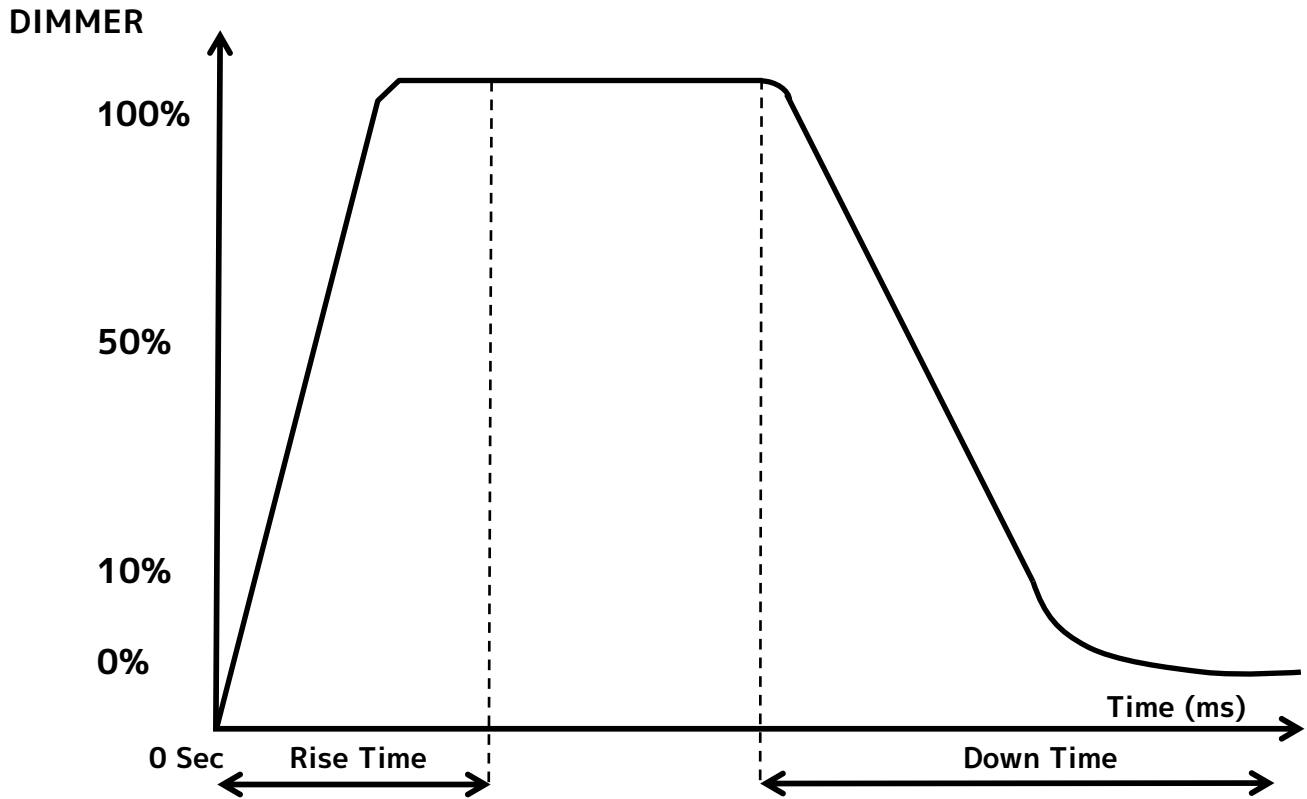

Dimming Curve Ramp Effect	0 sec Fade Time		1 sec Fade Time	
	Rise Time (ms)	Down Time (ms)	Rise Time (ms)	Down Time (ms)
Standard (default)	0	0	0	0
Stage	780	1100	1540	1660
TV	1180	1520	1860	1940
Architectural	1380	1730	2040	2120
Theatre	1580	1940	2230	2280
Stage 2	0	1100	0	1660

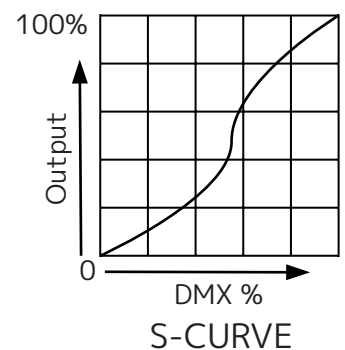
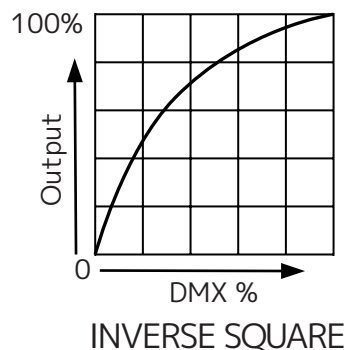
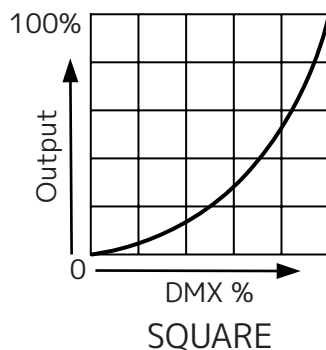
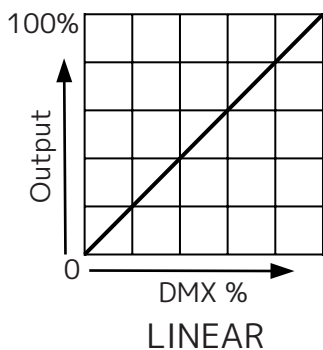

CLEANING & MAINTENANCE

WARNING! DISCONNECT UNIT FROM POWER BEFORE PERFORMING ANY CLEANING OR MAINTENANCE PROCEDURES!

ALWAYS ALLOW THE FIXTURE TO COOL FOR AT LEAST 15 MINUTES BEFORE PERFORMING ANY CLEANING OR MAINTENANCE!

CLEANING

Frequent cleaning is recommended to ensure proper function, optimized light output, and an extended life. The frequency of cleaning depends on the environment in which the fixture operates: damp, smoky, or particularly dirty environments can cause greater accumulation of dirt on the fixture's optics. Clean periodically with a soft cloth to avoid dirt/debris accumulation.

NEVER use alcohol, solvents, or ammonia-based cleaners.

MAINTENANCE

Regular inspections are recommended to ensure proper function and extended life. There are no user serviceable parts inside this fixture. Please refer all other service issues to an authorized ADJ service technician. Should you need any spare parts, please order genuine parts from an authorized ADJ dealer.

Please refer to the following points during routine inspections:

- A detailed electrical check by an approved electrical engineer every three months, to make sure the circuit contacts are in good condition and prevent overheating.
- Be sure all screws and fasteners are securely tightened at all times. Loose screws may fall out during normal operation, resulting in damage or injury as larger parts could fall.
- Check for any deformations on the housing, color lenses, rigging hardware and rigging points (ceiling, suspension, trussing). Deformations in the housing could allow for dust to enter into the fixture. Damaged rigging points or unsecured rigging could cause the fixture to fall and seriously injure a person(s).
- Electric power supply cables must not show any damage, material fatigue or sediments.

TORQUE SETTINGS FOR SCREWS

TORQUE DRIVERS (Recommended): UTICA TS-30 (Shown)

TORQUE DRIVER (Alternate):

- Proto J6107A
- Wiha 28887



The recommended torque setting for the Element H IP / Element H IP Chrome is as follows:

- 3.6 lb-in (4.2 kg-cm) for display screen panel / battery cover screws
- 11.3 lb-in (13.0 kg-cm) for all other screws

CAUTION! DO NOT OVER TORQUE SCREWS AS THIS CAN CAUSE LEAKAGE ISSUES!

DIMENSIONS

Dimensions not to scale.

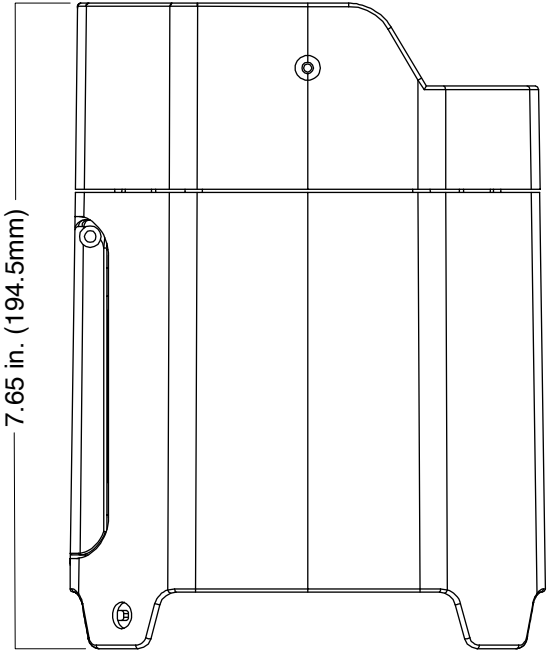
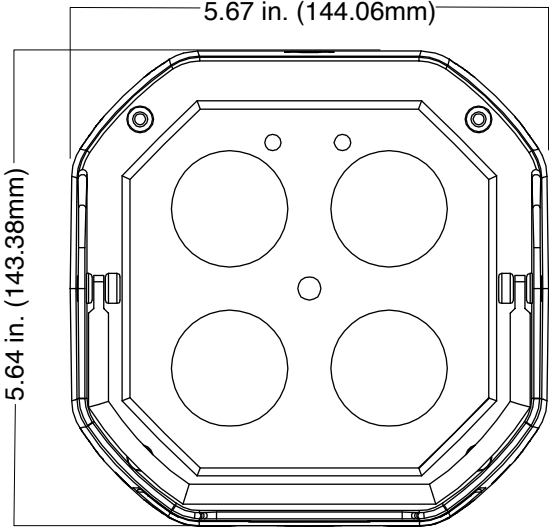

SPECIFICATIONS

Optical:

- 4 x 20-Watt RGBAW+UV LEDs (6-in-1 - Red, Green, Blue, Amber White & UV)
- Life expectancy: rated at 50,000 hrs.
- LUX: 1117 @ 2M; 298 @ 4M
- Beam angle: 17.6°
- Field angle: 28.7°

Connection:

- DMX: Wireless DMX
- With Wired Digital Communication Network
- Contact Charging system. *Charging base and power supply included

Control:

- Control protocol: Wireless DMX
- 7 DMX Channel modes: 6, 8, 9, 12, 14, 15 or 17 channels
- Remote control: Wireless DMX, UCIR24 (Included)
- 5 Operational modes: RGBAW+UV Dimmer Mode; Auto Run Mode (13 programs, & 1 color/fade combo mode); Static Color mode; and Wireless DMX Control

Features:

- IP54 Rated: partial protection from dust and water splashes
- Built-in kickstand to angle fixture when sitting on the floor
- 4-touch button OLED display inside cover panel
- Built-in Wireless DMX with signal LED indicator
- 63 built-in Color Macros
- Variable RGBAW+UV color mixing offers a smooth, seemingly unlimited color palette - Great for Stage or Wall Washing!
- LED pulse and strobe effect (0.2Hz-11Hz)
- Flicker Free Operation
- Electronic Dimming: 0 - 100% with 6 dim modes and 4 dim curves
- Run all night – No duty cycle
- Battery charge indicator on each fixture
- Energy Save Mode

Battery:

- Battery Type: fixed lithium ion battery
- Battery Energy: 59.2WH (Watt Hours)
- Battery Weight: 0.24 kg.
- Battery Voltage: 14.8V
- Battery Capacity: 4000mAh (Typical Capacity)
- Total Lithium Ion Cells: 8 pieces
- Battery Wrap Material: PVC sleeving + highland barley paper
- Battery Charge Time: 6 Hours
- Battery Life: 6 Hours in Normal mode and 12 hours in Energy save mode (single color)
- Easy to Replace Battery

Electrical:

- Power Draw Total (All LED's @ Full On): 20W
- Voltage operation: DC17V

Dimensions / Weight:

- Dimensions (LxWxH): 5.64" x 5.67" x 7.65" / 143.38 x 144.06 x 194.5mm
- Weight: 5.3 lbs. / 2.4kg.

Certifications:

- cETLus Control #4002034
- CE
- IP54 Outdoor rated
- FCC Approved

Specifications subject to change without notice.

FCC STATEMENT

This device complies with Part 15 of the FCC Rules. Operation is subject to the following two conditions: (1) this device may not cause harmful interference, and (2) this device must accept any interference received, including interference that may cause undesired operation.

FCC RADIO FREQUENCY INTERFERENCE WARNINGS & INSTRUCTIONS

This equipment has been tested and found to comply with the limits for a Class A digital device, pursuant to part 15 of the FCC Rules. These limits are designed to provide reasonable protection against harmful interference when the equipment is operated in a commercial environment. This equipment generates, uses, and can radiate radio frequency energy and, if not installed and used in accordance with the instruction manual, may cause harmful interference to radio communications. Operation of this equipment in a residential area is likely to cause harmful interference in which case the user will be required to correct the interference at his own expense.

Europe Energy Saving Notice

Energy Saving Matters (EuP 2009/125/EC)

Saving electric energy is a key to help protecting the environment. Please turn off all electrical products when they are not in use. To avoid power consumption in idle mode, disconnect all electrical equipment from power when not in use. Thank you



