

# **FOCUS FLEX L7**

## **User Instructions**

©2022 ADJ Products, LLC all rights reserved. Information, specifications, diagrams, images, and instructions herein are subject to change without notice. ADJ Products, LLC logo and identifying product names and numbers herein are trademarks of ADJ Products, LLC. Copyright protection claimed includes all forms and matters of copyrightable materials and information now allowed by statutory or judicial law or hereinafter granted. Product names used in this document may be trademarks or registered trademarks of their respective companies and are hereby acknowledged. All non-ADJ Products, LLC brands and product names are trademarks or registered trademarks of their respective companies.

**ADJ Products, LLC** and all affiliated companies hereby disclaim any and all liabilities for property, equipment, building, and electrical damages, injuries to any persons, and direct or indirect economic loss associated with the use or reliance of any information contained within this document, and/or as a result of the improper, unsafe, insufficient and negligent assembly, installation, rigging, and operation of this product.

**ADJ PRODUCTS LLC World Headquarters**

6122 S. Eastern Ave. | Los Angeles, CA 90040 USA

Tel: 800-322-6337 | Fax: 323-582-2941 | [www.adj.com](http://www.adj.com) | [lsupport@adj.com](mailto:lsupport@adj.com)

**ADJ Supply Europe B.V.**

Junostraat 2 | 6468 EW Kerkrade | Netherlands

Tel: +31 45 546 85 00 | Fax: +31 45 546 85 99 | [www.americandj.eu](http://www.americandj.eu) | [service@americandj.eu](mailto:service@americandj.eu)

Europe Energy Saving Notice

Energy Saving Matters (EuP 2009/125/EC)

Saving electric energy is a key to help protecting the environment. Please turn off all electrical products when they are not in use. To avoid power consumption in idle mode, disconnect all electrical equipment from power when not in use. Thank you!

**DOCUMENT VERSION**



Due to additional product features and/or enhancements, an updated version of this document may be available online.

Please check [www.adj.com](http://www.adj.com) for the latest revision/update of this manual before beginning installation and/or programming.

Date	Document Version	Software Version >	DMX Channel Mode	Notes
06/28/22	1	1.01	16/25/34/42/50/25/28	Initial Release
11/01/22	1.1	N/C	No Change	Update Dimensions
11/19/24	1.2	1.05	16/25/34/42/50/26/25/28	Updated System Menu, DMX Traits, DMX Addressing, RDM, Specifications; Added Aria Setup, Pixel Map

# CONTENTS

<b>General Information</b>	<b>4</b>
<b>Limited Warranty (USA Only)</b>	<b>5</b>
<b>Safety Guidelines</b>	<b>6</b>
<b>Overview</b>	<b>9</b>
<b>Virtual Swatch Colors</b>	<b>10</b>
<b>Color Macro Chart</b>	<b>11</b>
<b>Fixture Installation</b>	<b>12</b>
<b>DMX Set Up</b>	<b>15</b>
<b>DMX Addressing</b>	<b>16</b>
<b>Remote Device Management (RDM)</b>	<b>17</b>
<b>System Menu</b>	<b>18</b>
<b>Aria Setup</b>	<b>23</b>
<b>Dimmer Curve</b>	<b>25</b>
<b>DMX Traits: Channel Functions &amp; Values</b>	<b>26</b>
<b>Pixel Map   Error Codes</b>	<b>31</b>
<b>Power Linking   Cleaning</b>	<b>32</b>
<b>Specifications</b>	<b>33</b>
<b>Dimensions</b>	<b>34</b>

# GENERAL INFORMATION

## INTRODUCTION

Please read and understand all instructions in this manual carefully and thoroughly before attempting to operate these products. These instructions contain important safety and use information.

## UNPACKING

The products in this kit have been thoroughly tested and have been shipped in perfect operating condition. Carefully check the shipping carton for damage that may have occurred during shipping. If the carton appears to be damaged, carefully inspect each unit included for damage and be sure all accessories necessary to operate the units have arrived intact. In the event damage has been found or parts are missing, please contact our customer support team for further instructions. Please do not return this kit to your dealer without first contacting customer support at the number listed below. Please do not discard the shipping carton in the trash. Please recycle whenever possible.

## WARRANTY RETURNS

All returned service items whether under warranty or not, must be freight pre-paid and accompany a return authorization (R.A.) number. The R.A. number must be clearly written on the outside of the return package. A brief description of the problem as well as the R.A. number must also be written down on a piece of paper and included in the shipping container. If the unit is under warranty, you must provide a copy of your proof of purchase invoice. Items returned without a R.A. number clearly marked on the outside of the package will be refused and returned at customer's expense. You may obtain a R.A. number by contacting customer support.

# LIMITED WARRANTY (USA ONLY)

- A. ADJ Products, LLC hereby warrants, to the original purchaser, ADJ Products, LLC products to be free of manufacturing defects in material and workmanship for a prescribed period from the date of purchase (see specific warranty period on reverse). This warranty shall be valid only if the product is purchased within the United States of America, including possessions and territories. It is the owner's responsibility to establish the date and place of purchase by acceptable evidence, at the time service is sought.
- B. For warranty service, you must obtain a Return Authorization number (RA#) before sending back the product-please contact ADJ Products, LLC Service Department at 800-322-6337. Send the product only to the ADJ Products, LLC factory. All shipping charges must be pre-paid. If the requested repairs or service (including parts replacement) are within the terms of this warranty, ADJ Products, LLC will pay return shipping charges only to a designated point within the United States. If the entire instrument is sent, it must be shipped in its original package. No accessories should be shipped with the product. If any accessories are shipped with the product, ADJ Products, LLC shall have no liability whatsoever for loss of or damage to any such accessories, or for the safe return thereof.
- C. This warranty is void if the serial number has been altered or removed; if the product is modified in any manner which ADJ Products, LLC concludes, after inspection, affects the reliability of the product, if the product has been repaired or service by anyone other than ADJ Products, LLC factory unless prior written authorization was issued to purchaser by ADJ Products, LLC; if the product is damaged because not properly maintained as set forth in the instruction manual.
- D. This is not a service contract, and this warranty does not include maintenance, cleaning or periodic check up. During the period specified above, ADJ Products, LLC will replace defective parts at its expense with new or refurbished parts, and will absorb all expenses for warranty service and repair labor by reason of defects in material or workmanship. The sole responsibility of ADJ Products, LLC under this warranty shall be limited to the repair of the product, or replacement thereof, including parts, at the sole discretion of ADJ Products, LLC. All products covered by this warranty were manufactured after August 15, 2012, and bear identifying marks to that effect.
- E. ADJ Products, LLC reserves the right to make changes in design and/or improvements upon its products without any obligation to include these changes in any products theretofore manufactured.
- F. No warranty, whether expressed or implied, is given or made with respect to any accessory supplied with products described above. Except to the extent prohibited by applicable law, all implied warranties made by ADJ Products, LLC in connection with this product, including warranties of merchantability or fitness, are limited in duration to the warranty period set forth above. And no warranties, whether expressed or implied, including warranties of merchantability or fitness, shall apply to this product after said period has expired. The consumer's and/or Dealer's sole remedy shall be such repair or replacement as is expressly provided above; and under no circumstances shall ADJ Products, LLC be liable for any loss or damage, direct or consequential, arising out of the use of, or inability to use, this product.
- G. This warranty is the only written warranty applicable to ADJ Products, LLC Products and supersedes all prior warranties and written descriptions of warranty terms and conditions heretofore published.

## LIMITED WARRANTY PERIODS

- **Non L.E.D. Lighting Products = 1-year (365 days) Limited Warranty** (Such as: Special Effect Lighting, Intelligent Lighting, UV lighting, Strobes, Fog Machines, Bubble Machines, Mirror Balls, Par Cans, Trussing, Lighting Stands etc. excluding LED and lamps)
- **Laser Products = 1 Year (365 Days) Limited Warranty** (excludes laser diodes which have 6 month limited warranty)
- **L.E.D. Products = 2-year (730 days) Limited Warranty** (excluding batteries which have a 180 day limited warranty)  
Note: 2 Year Warranty only applies to purchases within the United States.
- **StarTec Series = 1 Year Limited Warranty** (excluding batteries which have a 180 day limited warranty)
- **ADJ DMX Controllers = 2 Year (730 Days) Limited Warranty**

# SAFETY GUIDELINES

To guarantee a smooth operation, it is important to follow all instructions and guidelines in this manual. ADJ Products, LLC is not responsible for injury and/or damages resulting from the misuse of this fixture due to the disregard of the information printed in this manual. Only qualified and/or certified personnel should perform installation of this fixture and only the original rigging parts included with this fixture should be used for installation. Any modifications to the fixture and/or the included mounting hardware will void the original manufacturer's warranty and increase the risk of damage and/or personal injury.



## **PROTECTION CLASS 1 - FIXTURE MUST BE PROPERLY GROUNDED**



**THERE ARE NO USER SERVICEABLE PARTS INSIDE THIS UNIT. DO NOT ATTEMPT ANY REPAIRS YOURSELF; DOING SO WILL VOID YOUR MANUFACTURER'S WARRANTY. DAMAGES RESULTING FROM MODIFICATIONS TO THIS FIXTURE AND/OR THE DISREGARD OF SAFETY INSTRUCTIONS AND GUIDELINES IN THIS MANUAL VOID THE MANUFACTURER'S WARRANTY AND ARE NOT SUBJECT TO ANY WARRANTY CLAIMS AND/OR REPAIRS.**



**DO NOT PLUG FIXTURE INTO A DIMMER PACK!  
NEVER OPEN THIS FIXTURE WHILE IN USE!  
UNPLUG POWER BEFORE SERVICING FIXTURE!**

**NEVER TOUCH FIXTURE DURING OPERATION AS IT MAY BE HOT! Maximum ambient temperature is 40°C. DO NOT operate it where the temperature is higher than this. Unit surface temperature may reach up to 75°C. DO NOT touch the housing bare-hand during its operation. Turn off the power and allow about 15 minutes for the unit to cool down before replacing or servicing.**

**KEEP FLAMMABLE MATERIALS AWAY FROM FIXTURE!**



**IF THE FIXTURE IS EXPOSED TO ENVIRONMENTAL TEMPERATURE CHANGES SUCH AS RELOCATION FROM AN OUTDOOR COLD TO AN INDOOR WARM ENVIRONMENT, DO NOT POWER THE FIXTURE ON IMMEDIATELY. INTERNAL CONDENSATION AS A RESULT OF ENVIRONMENTAL TEMPERATURE CHANGE CAN CAUSE INTERNAL FIXTURE DAMAGE. LEAVE THE FIXTURE POWERED OFF UNTIL IT HAS REACHED ROOM TEMPERATURE BEFORE POWERING ON.**

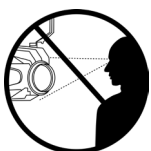

**NEVER LOOK DIRECTLY INTO THE LIGHT SOURCE! RETINA INJURY RISK - MAY INDUCE BLINDNESS! SENSITIVE PERSONS MAY SUFFER AN EPILEPTIC SHOCK! THIS IS A RISK GROUP 3 (HIGH RISK) PRODUCT ACCORDING TO EN 62471 AND IEC/TR 62778. THE LUMINAIRE SHOULD BE POSITIONED 63 METERS OR MORE FROM THE OUTPUT OF THE FIXTURE TO REDUCE OR ELIMINATE EXPOSURE.**

# SAFETY GUIDELINES

## **CAUTION**

### **HIGH INTENSITY ULTRAVIOLET LIGHT**



AVOID DIRECT EYE & SKIN EXPOSURE.  
WEAR PROPER EYE & SKIN PROTECTION.  
SEE MANUAL FOR SAFETY INSTRUCTIONS

**RISKGROUP3-RISKOFEXPOSURETOULTRAVIOLETUVRADIATION!  
FIXTURE EMITS HIGH INTENSITY WAVELENGTH OF ULTRAVIOLET  
UV LIGHT FROM THE UV COLOR FILTER. WEAR PROPER EYE AND  
SKIN PROTECTION. AVOID PROLONGED PERIODS OF EXPOSURE  
TO UV COLOR FILTER. AVOID WEARING WHITE COLOR CLOTHING  
AND/OR USING UV PAINTS ON SKIN. AVOID DIRECT EYE AND/OR  
SKIN. EXPOSURE AT DISTANCES LESS THAN 11 feet (3.3m). DO  
NOT OPERATE FIXTURE WITH DAMAGED/MISSING EXTERNAL  
COVERS. DO NOT LOOK DIRECTLY INTO THE UV LIGHT AND/  
OR VIEW UV LIGHT DIRECTLY WITH OPTICAL INSTRUMENTS  
THAT MAY CONCENTRATE THE LIGHT/RADIATION OUTPUT.  
INDIVIDUALS SUFFERING FROM A RANGE OF EYE CONDITIONS,  
SUNLIGHT EXPOSURE DIS-ORDERS, OR INDIVIDUALS USING  
PHOTOSENSITIVE MEDICATION, MAY RECEIVE DISCOMFORT IF  
EXPOSED TO THE ULTRAVIOLET UV LIGHT EMITTED FROM THE  
UV LED.**

- **DO NOT TOUCH** the fixture housing during operation. Turn OFF the power and allow approximately 15 minutes for the fixture to cool down before servicing.
- **DO NOT** shake fixture; avoid brute force when installing and/or operating fixture.
- **DO NOT** operate fixture if the power cord has become frayed, crimped, damaged and/or if any of the power cord connectors are damaged and do not insert into the fixture securely with ease.
- **NEVER** force a power cord connector into the fixture. If the power cord or any of its connectors are damaged, replace it immediately with a new one of similar power rating.
- **DO NOT** block any air ventilation slots; these must remain clean and never blocked. Allow approx. 7.9" (20cm) between fixture and other devices or a wall for proper cooling.
- When installing fixture in a suspended environment, always use mounting hardware that is no less than M10 x 25 mm, and always attach an appropriately rated safety cable.
- **ALWAYS** disconnect fixture from main power source before performing any type of service and/or cleaning procedure. Only handle the power cord by the plug end; never pull out the plug by tugging the wire portion of the cord.
- During the initial operation of this fixture, a light smoke or smell may emit from the interior of the fixture. This is a normal process and is caused by excess paint in the interior of the casing burning off from the heat associated with the lamp and will decrease gradually over time.
- Consistent operational breaks will ensure fixture will function properly for many years. **ONLY** use the original packaging and materials to transport the fixture in for service.

# SAFETY GUIDELINES

## POTENTIAL INTERNAL FIXTURE DAMAGE FROM EXTERNAL SOURCES OF LIGHT BEAMS

External sources of light beams from direct sunlight, lighting moving head fixtures, and lasers, which are focused directly towards the exterior housing and/or penetrate the front lens opening of ADJ lighting fixtures, can cause severe internal damage including burning to optics, dichroic color filters, glass and metal gobos, prisms, animation wheels, frost filters, iris, shutters, motors, belts, wiring, discharge lamps, and LEDs.

This issue is not specific only to ADJ lighting fixtures, it is a common issue with lighting fixtures from all manufacturers. Although there is no true way to fully prevent this issue from happening, the guidelines below can prevent any potential damage from occurring if followed. Contact ADJ Service for more details.

**DO NOT EXPOSE THE FIXTURE AND/OR FRONT LENS OPENING TO LIGHT BEAMS FROM DIRECT SUNLIGHT, OTHER LIGHTING MOVING HEAD FIXTURES, AND LASERS WHILE UNPACKING, INSTALLATION, USE, AND EXTENDED IDLE TIMES OUTDOORS.**  
**DO NOT FOCUS A LIGHT BEAM FROM ONE LIGHTING FIXTURE DIRECTLY TOWARDS ANOTHER.**

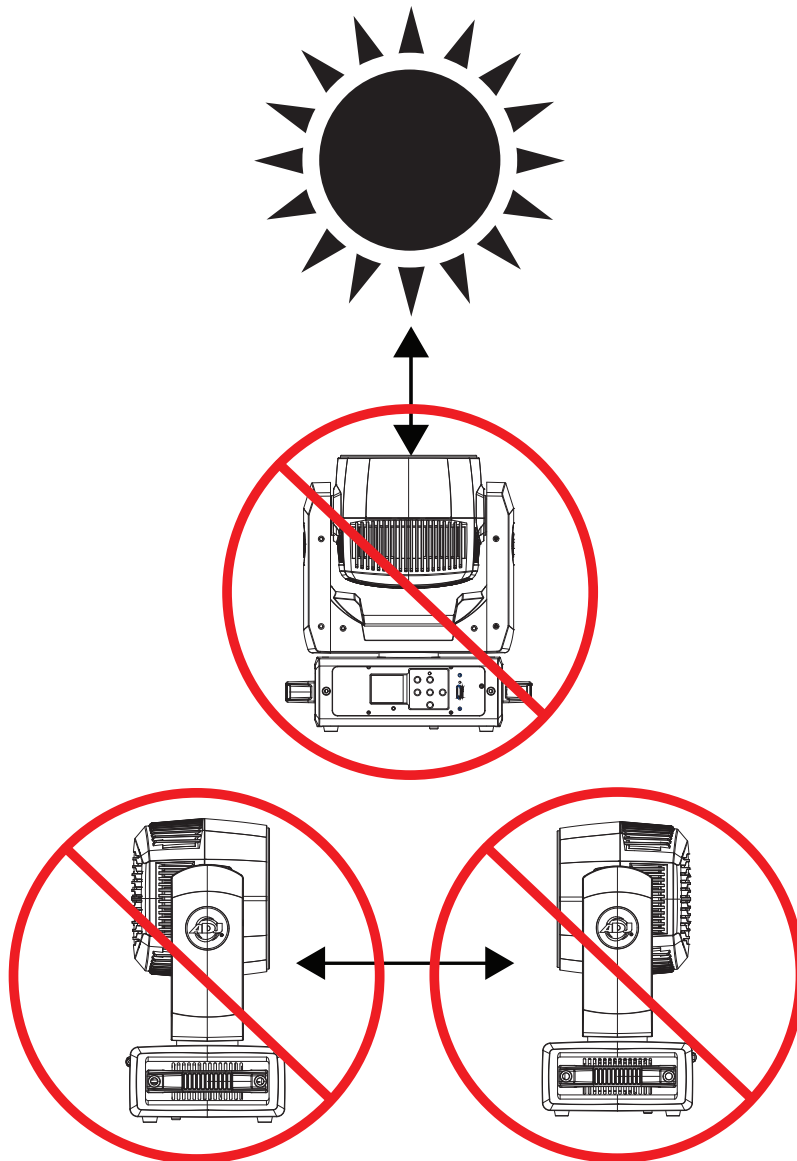



# OVERVIEW

7X RGBL LEDs

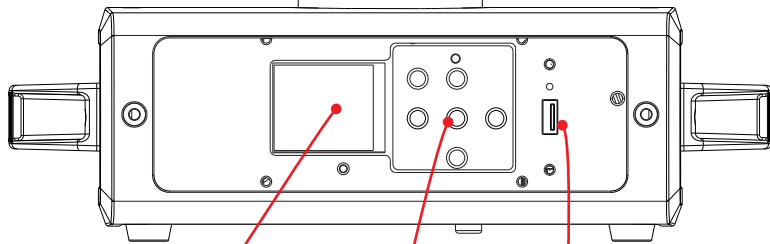
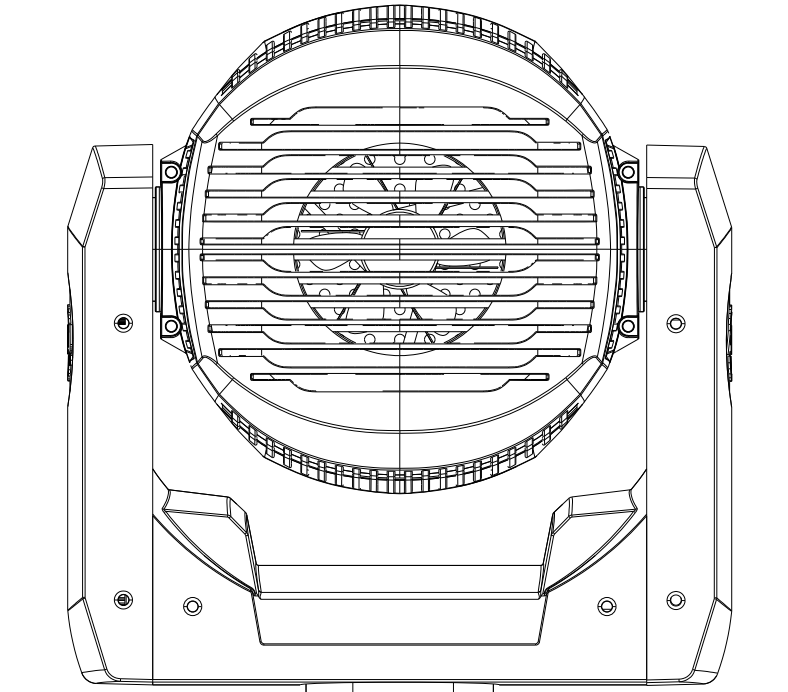
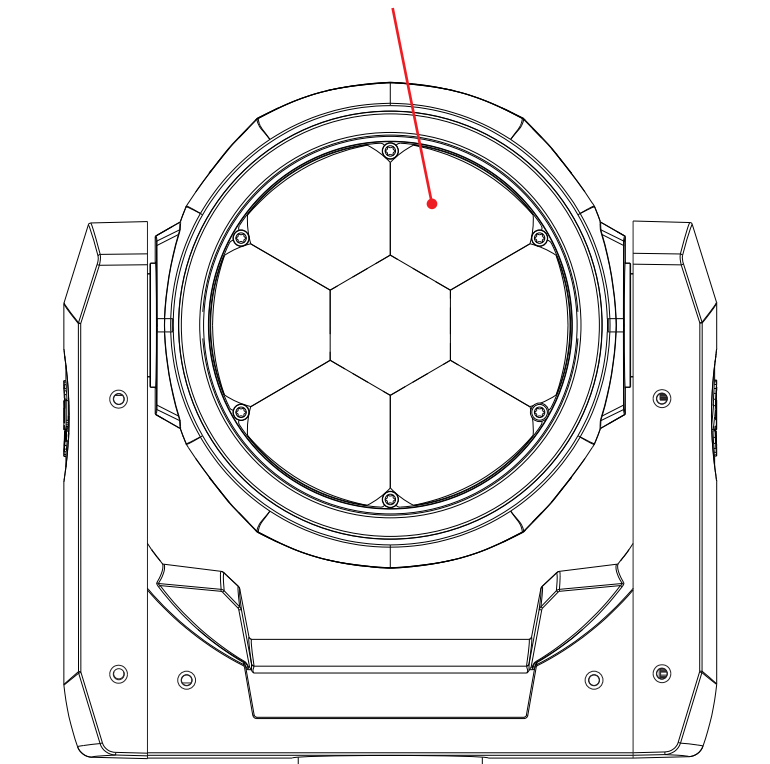

LCD Menu Display

Menu Controls

USB Service Port

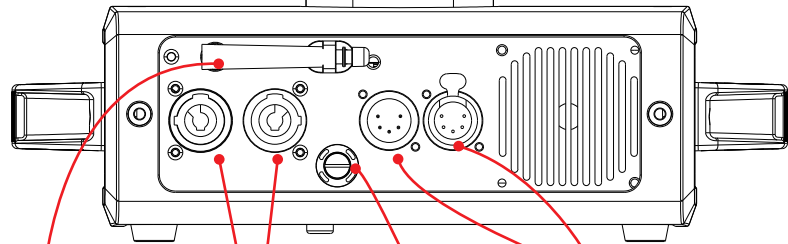

Wifly Antenna

Locking Power Connector In/Out

Fuse: T10A

5-Pin DMX In/Out

# VIRTUAL SWATCH COLORS

VIRTUAL GEL SWATCH BOOK COLORS								
Value	Filter Number	Name	Value	Filter Number	Name	Value	Filter Number	Name
1	7	Pale Yellow	21	157	Pink	41	68	Sky Blue
2	103	Straw	22	36	Medium Pink	42	143	Pale Navy Blue
3	151	Gold Tint	23	111	Dark Pink	43	131	Marine Blue
4	100	Spring Yellow	24	128	Bright Pink	44	115	Peacock Blue
5	10	Medium Yellow	25	148	Bright Rose	45	172	Lagoon Blue
6	101	Yellow	26	332	Special Rose Pink	46	116	Medium Blue Green
7	104	Deep Amber	27	793	Vanity Fair	47	90	Dark Yellow Green
8	15	Deep Straw	28	113	Magenta	48	139	Primary Green
9	179	Loving Amber	29	46	Dark Magenta	49	122	Fern Green
10	21	Gold Amber	30	48	Rose Purple	50	89	Moss Green
11	105	Orange	31	126	Mauve	51	124	Dark Green
12	158	Deep Orange	32	49	Medium Purple	52	88	Lime Green
13	22	Dark Amber	33	58	Lavender	53	138	Pale Green
14	778	Millennium Gold	34	199	Palace Blue	54	203	Quarter CT Blue
15	135	Deep Golden Amber	35	119	Dark Blue	55	202	Half CT Blue
16	24	Scarlet	36	132	Medium Blue	56	201	FULL CT Blue
17	106	Primary Red	37	120	Deep Blue	57	200	Double CT Blue
18	26	Bright Red	38	165	Daylight Blue	58	206	Quarter CT Orange
19	27	Medium Red	39	161	Slate Blue	59	205	Half CT Orange
20	19	Fire	40	118	Light Blue	60	204	FULL CT Orange

# COLOR MACRO CHART

Color	DMX Value	RGLB COLOR INTENSITY				Color	DMX Value	RGLB COLOR INTENSITY			
		RED	GREEN	BLUE	LIME			RED	GREEN	BLUE	LIME
Off	0	0	0	0	0	Color Macro 33	129-132	255	206	143	0
Color Macro 1	1-4	80	255	234	80	Color Macro 34	133-136	254	177	153	0
Color Macro 2	5-8	80	255	164	80	Color Macro 35	137-140	254	192	138	0
Color Macro 3	9-12	77	255	112	77	Color Macro 36	141-144	254	165	98	0
Color Macro 4	13-16	117	255	83	83	Color Macro 37	145-148	254	121	0	0
Color Macro 5	17-20	160	255	77	77	Color Macro 38	149-152	176	17	0	0
Color Macro 6	21-24	223	255	83	83	Color Macro 39	153-156	96	0	11	0
Color Macro 7	25-28	255	243	77	77	Color Macro 40	157-160	234	139	171	0
Color Macro 8	29-32	255	200	74	74	Color Macro 41	161-164	224	5	97	0
Color Macro 9	33-36	255	166	77	77	Color Macro 42	165-168	175	77	173	0
Color Macro 10	37-40	255	125	74	74	Color Macro 43	169-172	119	130	199	0
Color Macro 11	41-44	255	97	77	71	Color Macro 44	173-176	147	164	212	0
Color Macro 12	45-48	255	74	77	71	Color Macro 45	177-180	88	2	163	0
Color Macro 13	49-52	255	83	134	83	Color Macro 46	181-184	0	38	86	0
Color Macro 14	53-56	255	93	182	93	Color Macro 47	185-188	0	142	208	0
Color Macro 15	57-60	255	96	236	96	Color Macro 48	189-192	52	148	209	0
Color Macro 16	61-64	238	93	255	93	Color Macro 49	193-196	1	134	204	0
Color Macro 17	65-68	163	87	255	87	Color Macro 50	197-200	0	145	212	0
Color Macro 18	69-72	150	90	255	90	Color Macro 51	201-204	0	121	192	0
Color Macro 19	73-76	100	77	255	77	Color Macro 52	205-208	0	129	184	0
Color Macro 20	77-80	77	100	255	77	Color Macro 53	209-212	0	83	115	0
Color Macro 21	81-84	67	148	255	67	Color Macro 54	213-216	0	97	166	0
Color Macro 22	85-88	77	195	255	77	Color Macro 55	217-220	1	100	167	0
Color Macro 23	89-92	77	234	255	77	Color Macro 56	221-224	0	40	86	0
Color Macro 24	93-96	158	255	144	144	Color Macro 57	225-228	209	219	182	0
Color Macro 25	97-100	255	251	153	153	Color Macro 58	229-232	42	165	85	0
Color Macro 26	101-104	255	175	147	147	Color Macro 59	233-236	0	46	35	0
Color Macro 27	105-108	255	138	186	138	Color Macro 60	237-240	8	107	222	0
Color Macro 28	109-112	255	147	251	147	Color Macro 61	241-244	255	0	0	0
Color Macro 29	113-116	151	135	255	138	Color Macro 62	245-248	0	255	0	0
Color Macro 30	117-120	99	0	255	100	Color Macro 63	249-252	0	0	255	0
Color Macro 31	121-124	138	169	255	138	Color Macro 64	253-255	0	0	0	255
Color Macro 32	128-128	255	255	255	255						

# FIXTURE INSTALLATION



## **FLAMMABLE MATERIAL WARNING**

Keep fixture at least 7.9in. (0.2m) away from any flammable materials, decorations, pyrotechnics, etc.



## **ELECTRICAL CONNECTIONS**

A qualified electrician should be used for all electrical connections and/or installations.



**MINIMUM DISTANCE TO OBJECTS/SURFACES MUST BE 40 FEET (12 METERS)**



**MAXIMUM TEMPERATURE OF EXTERNAL SURFACE 167°F (75°C)**

## **DO NOT INSTALL THE FIXTURE IF YOU ARE NOT QUALIFIED TO DO SO!**

Fixture **MUST** be installed following all local, national, and country commercial electrical and construction codes and regulations. Before rigging/mounting the fixture to any metal truss/structure or placing the fixture on any surface, a professional equipment installer **MUST** be consulted to determine if the metal truss/structure or surface is properly certified to safely hold the combined weight of the fixture, clamps, cables, and accessories.

Overhead fixture installation must always be secured with a secondary safety attachment, such as an appropriately rated safety cable that meets all local, national, and country codes and regulations.

Fixture ambient operating temperature range is **-4°F to 104°F. (-20°C to 40°C)** Do not use this fixture outside this temperature range.

Fixture should be installed in areas outside walking paths, seating areas, or away from areas where unauthorized personnel might reach the fixture by hand.

**NEVER** stand directly below the fixture when rigging, removing, or servicing.

Allow approximately 15-minutes for the fixture to cool down before servicing.

# FIXTURE INSTALLATION

**NOTICE:** The suitable environmental temperature for this lighting fixture is between  $-20^{\circ}\text{C}$  to  $40^{\circ}\text{C}$ . Do not place this lighting fixture in an environment where the temperatures are under or above the temperatures stated above. This will allow the fixture to run at its best and help prolong the fixture life.

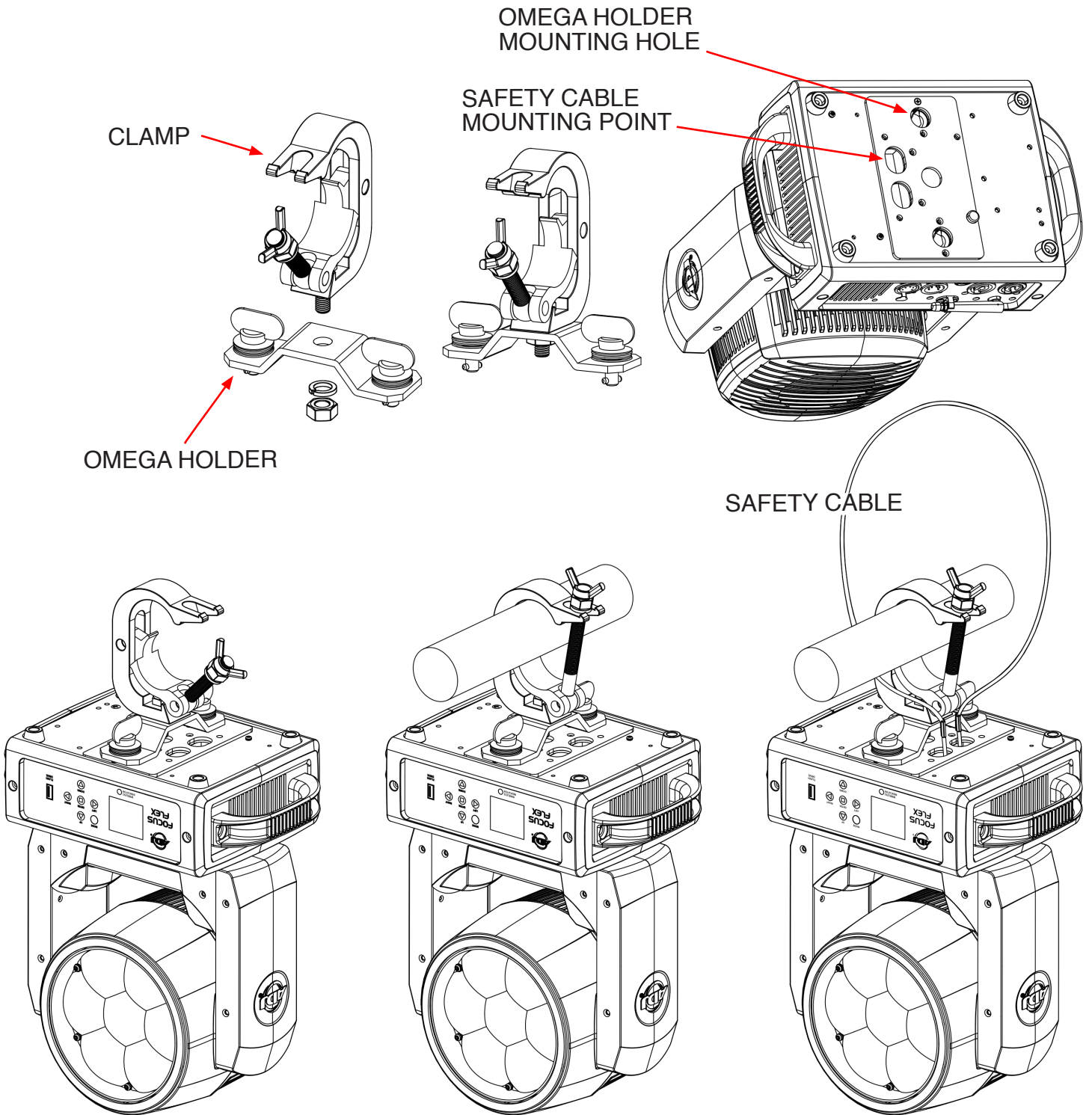

Screw one clamp via a M12 screw and nut into the Omega holder. Insert the quick-lock fasteners of the Omega holder into the respective holes of the adjustable mounting bracket. Tighten the quick-lock fasteners fully clockwise. Pull the safety-cable through the opening located on the bottom of the unit and over the trussing system or a safe fixation spot. Insert the end in the carabiner and tighten the safety screw.

# FIXTURE INSTALLATION

When installing the unit, the trussing or area of installation must be able to hold 10 times the weight without any deformation. When installing the unit must be secured with a secondary safety attachment, e.g. and appropriate safety cable. Never stand directly below the unit when mounting, removing, or servicing the unit.

Overhead mounting requires extensive experience, including calculating working load limits, installation material being used, and periodic safety inspection of all installation material and unit. If you lack these qualifications, do not attempt the installation yourself.

NOTE: These installations should be checked by a skilled person once a year.

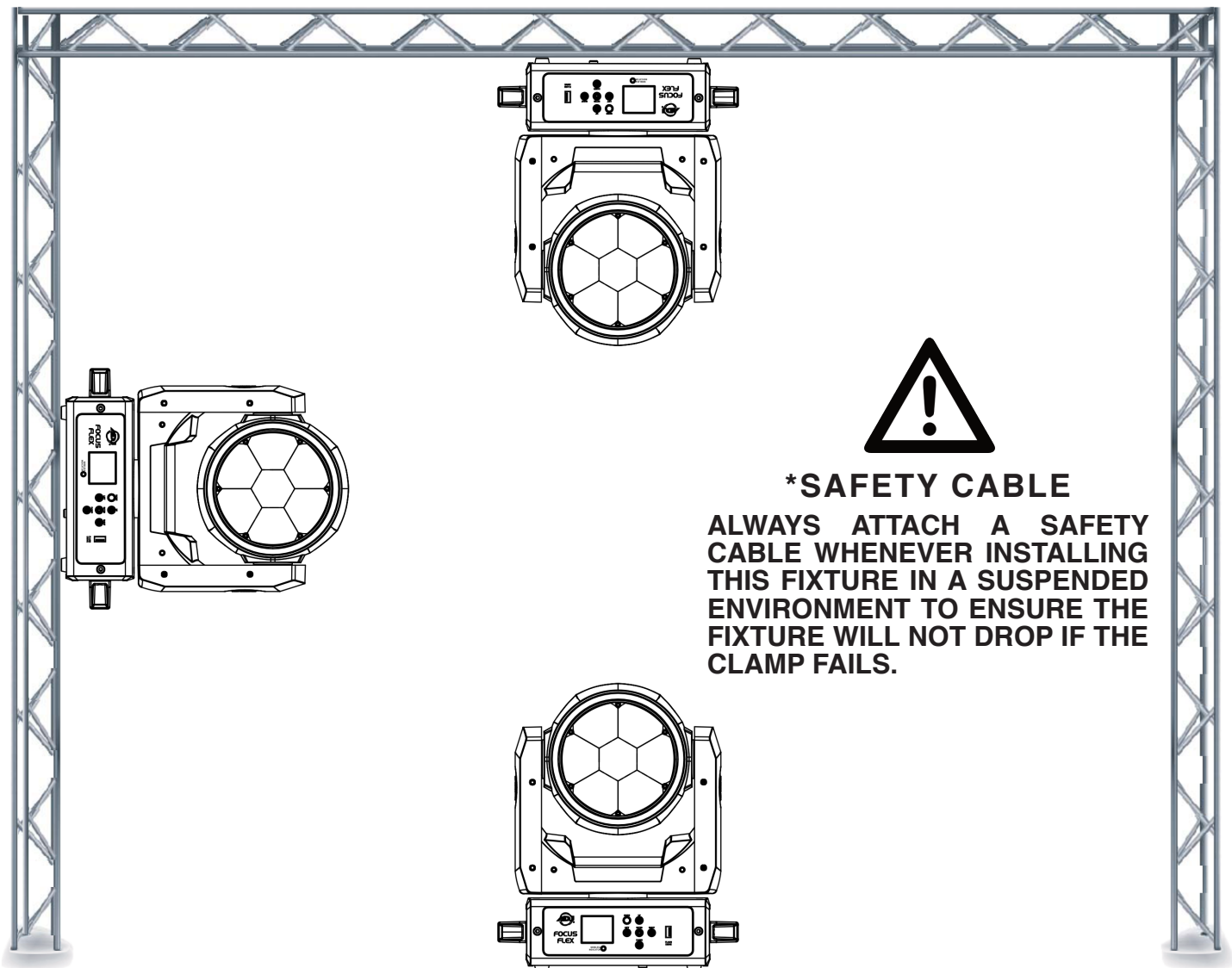

The Focus Flex is fully operational in three different mounting positions, hanging upside-down, mounted sideways on trussing, or set on a flat level surface. Be sure this fixture is kept at least 0.2m (7.9in.) away from any flammable materials (decoration etc.). Always use and install the supplied safety cable as a safety measure to prevent accidental damage and/or injury in the event the clamp fails (see next page). Never use the carrying handles for secondary attachment.

# DMX SETUP

**DMX-512:** DMX is short for Digital Multiplex. This is a universal protocol used as a form of communication between intelligent fixtures and controllers. A DMX controller sends DMX data instructions from the controller to the fixture. DMX data is sent as serial data that travels from fixture to fixture via the DATA “IN” and DATA “OUT” XLR terminals located on all DMX fixtures (most controllers only have a DATA “OUT” terminal).

**DMX Linking:** DMX is a language allowing all makes and models of different manufactures to be linked together and operate from a single controller, as long as all fixtures and the controller are DMX compliant. To ensure proper DMX data transmission, when using several DMX fixtures try to use the shortest cable path possible. The order in which fixtures are connected in a DMX line does not influence the DMX addressing. For example; a fixture assigned a DMX address of 1 may be placed anywhere in a DMX line, at the beginning, at the end, or anywhere in the middle. When a fixture is assigned a DMX address of 1, the DMX controller knows to send DATA assigned to address 1 to that unit, no matter where it is located in the DMX chain.

**Data Cable (DMX Cable) Requirements (For DMX Operation):** This unit can be controlled via DMX-512 protocol. Your unit and your DMX controller requires a 5-pin XLR connector for data input/output. We recommend Accu-Cable DMX cables. If you are making your own cables, be sure to use standard 110-120 Ohm shielded cable (This cable may be purchased at almost all pro lighting stores). Your cables should be made with a male and female XLR connector on either end of the cable. Also remember that DMX cable must be daisy chained and cannot be split.

**Notice:** Be sure to follow figures two and three when making your own cables. Do not use the ground lug on the XLR connector. Do not connect the cable’s shield conductor to the ground lug or allow the shield conductor to come in contact with the XLR’s outer casing. Grounding the shield could cause a short circuit and erratic behavior.

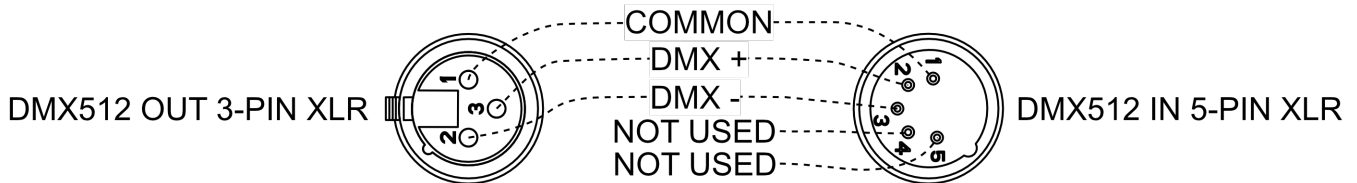

3-Pin XLR to 5-Pin XLR Conversion		
Ground/Shield	Pin 1	Pin 1
Data Compliment (- signal)	Pin 2	Pin 2
Data True (+ signal)	Pin 3	Pin 3
Not Used		Do Not Use
Not Used		Do Not Use

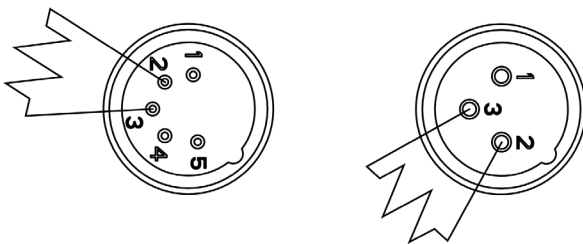

A DMX512 terminator reduces signal errors, avoiding most signal reflection interference. Connect PIN 2 (DMX-) and PIN 3 (DMX+) of the last fixture in series with a 120 Ohm, 1/4 W Resistor to terminate the DMX512.

**Special Note: Line Termination.** When longer runs of cable are used, you may need to use a terminator on the last unit to avoid erratic behavior. A terminator is a 110-120 ohm 1/4 watt resistor which is connected between pins 2 and 3 of a male XLR connector (DATA + and DATA -). This unit is inserted in the female XLR connector of the last unit in your daisy chain to terminate the line. Using a cable terminator (ADJ part number Z-DMX/T) will decrease the possibilities of erratic behavior.

## DMX ADDRESSING

All fixtures should be given a DMX starting address when using a DMX controller, so the correct fixture responds to the correct control signal. This digital starting address is the channel number from which the fixture starts to “listen” to the digital control signal sent out from the DMX controller. The assignment of this starting DMX address is achieved by setting the correct DMX address on the digital control display on the fixture.

You can set the same starting address for all fixtures or a group of fixtures, or set different addresses for each individual fixture. Setting all fixtures to the same DMX address will cause all fixtures to react in the same way, in other words, changing the settings of one channel will affect all the fixtures simultaneously.

If you set each fixture to a different DMX address, each unit will start to “listen” to the channel number you have set, based on the quantity of DMX channels of each fixture. That means changing the settings of one channel will only affect the selected fixture. In the case of the Focus Flex, when in 16 Channel mode, you should set the starting DMX address of the first unit to 1, the second unit to 17 (1 + 16), the third unit to 33 (17 + 16), the fourth unit to 49 (33 + 16), etc...

Channel Mode	Unit 1 Address	Unit 2 Address	Unit 3 Address	Unit 4 Address
<b>Basic: 16 Channels</b>	<b>1</b>	<b>17</b>	<b>33</b>	<b>49</b>
<b>Standard: 25 Channels</b>	<b>1</b>	<b>26</b>	<b>51</b>	<b>76</b>
<b>Extended 3: 34 Channels</b>	<b>1</b>	<b>35</b>	<b>69</b>	<b>103</b>
<b>Extended 5: 42 Channels</b>	<b>1</b>	<b>43</b>	<b>85</b>	<b>127</b>
<b>Extended 7: 50 Channels</b>	<b>1</b>	<b>51</b>	<b>101</b>	<b>151</b>
<b>Standard RGBW : 26 Channels</b>	<b>1</b>	<b>27</b>	<b>53</b>	<b>79</b>
<b>Standard CMY: 25 Channels</b>	<b>1</b>	<b>26</b>	<b>51</b>	<b>76</b>
<b>Extended CMY: 28 Channels</b>	<b>1</b>	<b>29</b>	<b>57</b>	<b>85</b>



## REMOTE DEVICE MANAGEMENT (RDM)

**NOTE: In order for RDM to work properly, RDM enabled equipment must be used throughout the entire system, including DMX data splitters and wireless systems.**

Remote Device Management (RDM) is a protocol that sits on top of the DMX512 data standard for lighting, and allows the DMX systems of the fixtures to be modified and monitored remotely. This protocol is ideal for instances in which a unit is installed in a location that is not easily accessible.

With RDM, the DMX512 system becomes bi-directional, allowing a compatible RDM enabled controller to send out a signal to devices on the wire, as well as allowing the fixture to respond (known as a GET command). The controller can then use its SET command to modify settings that would typically have to be changed or viewed directly via the unit's display screen, including the DMX Address, DMX Channel Mode, and Temperature Sensors.

### FIXTURE RDM INFORMATION:

Device ID	Device Model ID	RDM Code	Personality ID
35 0000-FFFF	35	0x1900	Basic 16 Standard 25 Extended 34 Extended 42 Extended 50 Standard RGBW 26 Standard CMY 25 Extended CMY 28

Please be aware that **not all RDM devices support all RDM features**, and therefore it is important to check beforehand to ensure that the equipment that you are considering includes all of the features that you require.

The following parameters are accessible in RDM on this device:

[0x0011] Proxied Device Count	[0x0032] Clear Status ID	[0x0603] Realtime Clock
[0x0200] Sensor Definition	[0x0401] Lamp Hours	[0x1010] Power State
[0x0201] Sensor Value	[0x0402] Lamp Strikes	[0x1031] Preset Playback
[0x0080] Device Model Description	[0x0403] Lamp State	[0x0122] Default Slot Value
[0x0081] Manufacturer Label	[0x0404] Lamp Mode	[0x00B0] Language
[0x0082] Device Label	[0x0405] Device Power Cycles	[0x00A0] Language Capabilities
[0x00E0] DMX Personality	[0x0600] Pan Invert	[0x00C2] Boot Software Version Label
[0x00E1] DMX Personality Description	[0x0601] Tilt Invert	[0x00C1] Boot Software Version ID
[0x0400] Device Hours	[0x0602] Pan Tilt Swap	[0x0070] Product Detail ID List
[0x0015] Comms Status	[0x0500] Display Invert	[0x0030] Status Messages
[0x0031] Status ID Description	[0x0501] Display Level	

## SYSTEM MENU

The fixture includes an easy to navigate system menu. The control panel located on the front of the fixture, provides access to the main system menu and is where all necessary system adjustments are made to the fixture. During normal operation, pressing **MODE** button once will access the fixture's main menu. Once in the main menu you can navigate through the different functions and access the sub-menus with the **UP**, **DOWN**, **RIGHT**, and **LEFT** buttons. Once you reach a field that requires adjusting, press the **ENTER** button to activate that field and use the **UP** and **DOWN** buttons to adjust the field. Pressing the **ENTER** button once more will confirm your setting. You may exit the main menu at any time without making any adjustments by pressing the **MODE** button.

**NOTE:** To access the LCD Menu Control Display via the internal battery, press and hold the **MODE** button for 10 seconds. The LCD Menu Control Display will shut **OFF** automatically about 1 minute from the last button press.

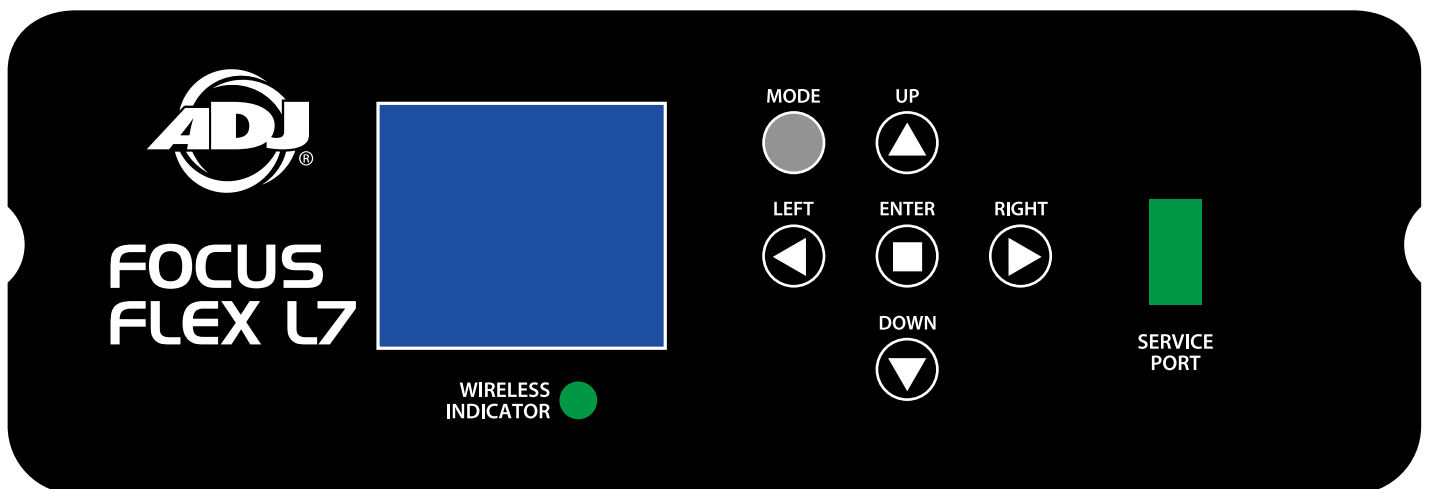

### KEY LOCK

This function allows the user to configure whether or not the display screen and control panel keys will lock after a certain period of inactivity. It can be accessed by navigating to Personality > Display > Key Lock in the system menu. The setting options are described below:

- OFF: The display screen and control panel keys remain active at all times.
- ON: The display screen and control panel keys automatically lock after a certain period of inactivity, which can be set under Personality > Display > Screen Saver Delay. To unlock, press and hold the **MODE** button for 3 seconds.
- ON1: The display screen and control panel keys automatically lock after a certain period of inactivity, which can be set under Personality > Display > Screen Saver Delay. To unlock, press **UP**, **DOWN**, **UP**, **DOWN**, **ENTER** in that order.

### SERVICE PORT / SOFTWARE UPDATES

Please contact ADJ customer support or latest software and updating instructions.

# SYSTEM MENU

Menu	Sub Menu	OPTIONS / VALUES (Default Settings in BOLD)	Description	
	DMX Address	<b>001</b> - XXX		
DMX Settings	DMX Channel Mode	Basic 16		
		<b>Standard 25</b>		
		Extended 34		
		Extended 42		
		Extended 50		
		Standard RGBW 26		
		Standard CMY 25		
		Extended CMY 28		
		User Mode		
	No DMX Status	<b>Hold Last</b>		
	Blackout			
	Manual			
Personality	Prim/Sec Mode	Primary / <b>Secondary</b>	When set to Primary and Entered, the unit shall function in Primary mode. When set to Secondary, the unit shall function in Secondary mode. All units shall be set to Secondary by default. When Primary is Entered and active, the unit shall function as the Primary unit and control secondary units that are connected in line to it. When Secondary is entered and active, the unit shall function as a secondary unit and shall only receive signal from a Primary unit.	
	Select Signal	DMX or Aria	DMX has priority. When Aria is connected, a green LED indicator shall be on solid. When Aria is not connected, a red LED indicator shall be on solid.	
		Aria and DMX Out	When Aria is connected, a green LED indicator shall be on solid. The DMX XLR output shall send DMX signal out.	
	Wifly Settings	Wifly Enable	<b>On</b> / Off	
		Set Wifly Channel	00 - 14	
	Status Settings	Pan Degree	<b>630</b> / 540	
		Tilt Degree	265 / <b>230</b>	
		Pan Invert	<b>ON</b> / OFF	
		Tilt Invert	<b>ON</b> / OFF	
		P./T. Feedback	<b>ON</b> / OFF	
		P./T. Speed	<b>Speed 1</b>	
			Speed 2	
	Hibernation	OFF, 01M~99M, <b>15M</b>		
	Fan Settings	Head Fan	<b>Auto</b>	
			High	
			Low	
			Mute	
Base Fan		<b>Auto</b>		
		High		
		Low		
		Mute		

# SYSTEM MENU

Menu	Sub Menu	OPTIONS / VALUES (Default Settings in <b>BOLD</b> )	Description
Personality	Zoom Speed	<b>Standard</b>	
		Fast	
	Zoom Mode	<b>Mode 1</b>	
		Mode 2	
	LED Power Mode	<b>LP Mode 1</b>	Standard max LED output mode
		LP Mode 2	Regulated LED output with 8500K target CCT
	Dim Modes	<b>Standard</b>	
		Stage	
		TV	
		Architectural	
		Theatre	
		Stage 2	
		Dim Speed	0.1S~10S
	LED Refresh Rate	900~1500, 2500, 4000, 5000, 6000, 10KHZ, 15KHZ, 20KHZ, 25KHZ, <b>1200HZ</b>	
	Dim Curve	Linear	
		<b>Square</b>	
		Inv.Squa	
		S.Curve	
	Reset Motors	Reset All Motors	YES / <b>NO</b>
		Pan/Tilt Reset	YES / <b>NO</b>
		Effect Reset	YES / <b>NO</b>
	Display	Intensity	<b>1-10</b>
		Display Invert	YES / <b>NO</b>
		Screen Saver Delay	OFF-10M, <b>05M</b>
		Key Lock	<b>OFF/ON/ON1</b>
	Set User Mode	Pan	<b>1</b>
		Pan Fine	<b>2</b>
		Tilt	<b>3</b>
		Tilt Fine	<b>4</b>
		Red 1	<b>5</b>
		Green 1	<b>6</b>
		Blue 1	<b>7</b>
Lime 1		<b>8</b>	
...		...	
Red 7		<b>29</b>	
Green 7		<b>30</b>	
Blue 7		<b>31</b>	
Lime 7		<b>32</b>	
...		...	
Program		<b>46</b>	
Program Speed		<b>47</b>	
Program Fade		<b>48</b>	
P/T Speed	<b>49</b>		
Special	<b>50</b>		

# SYSTEM MENU

Menu	Sub Menu			Description	
Personality	Service	Pass-code	Effect Adjust (Calibration) 050	Pan 000-55	
				Tilt 000-255	
				Red 000-255	
				Green 000-255	
				Blue 000-255	
				LIME 000-255	
				...	
		Color Calibration	<b>Enable</b> / Disable	When enabled, unit uses calibrated data. When disabled, unit will output to fullest.	
		USB Port Power	OFF/ <b>ON</b>		
Update Software	OFF/ <b>ON</b>				
Factory Restore	OFF/ <b>ON</b>	Passcode = 011			
Manual Control	Pan	000-255			
	Pan Fine	000-255			
	Tilt	000-255			
	Tilt Fine	000-255			
	....	...			
Internal Programs	Program 1	Speed	000-255		
		Fade	000-255		
	Program 2	Speed	000-255		
		Fade	000-255		
	Program 3	Speed	000-255		
		Fade	000-255		
	Program 4	Speed	000-255		
		Fade	000-255		
	Program 5	Speed	<b>000-255</b>		
		Fade	000-255		
	Program 6	Speed	000-255		
		Fade	000-255		
	...	...	...		
	Program 20	Speed	000-255		
Fade		000-255			

# SYSTEM MENU

Menu	Sub Menu			Description
Information	Fixture Lifetime	Power On Time	xxxxxx Hours	
		P-On Time-R	xxxxxx Hours	
		P-On Time-Reset		
	Total LED Time	LED On Time	xxxxxx Hours	
		LED On Time-R	xxxxxx Hours	
		LED Hours Reset	Passcode 050	
	Fixture Temps	LEDs	Current	T: xxxx°F/xxxx°C
			Max. Resettable	T: xxxx°F/xxxx°C
		Base Temp	Current	T: xxxx°F/xxxx°C
			Max. Resettable	T: xxxx°F/xxxx°C
		Reset LED Temp	YES / <b>NO</b>	Passcode: <b>050</b>
		Reset Base Temp	YES / <b>NO</b>	Passcode: <b>050</b>
	Fan Info. (RPM)	LED Fan	xxxxRPM LED	
		BaseFan	xxxxRPM	
	DMX Values	Pan		
		Pan Fine		
		...		
	Error Logs	xxxxx	List Errors one by one	
		xxxxx		
		Reset Error Log	YES / <b>NO</b>	Passcode: 050
	Software Version	1U:XXX 2U:XXX 3U:XXX		
	Aria ID	xx:xx:xx:xx:xx:xx		

# ARIA SETUP



**BEFORE SETTING THE ARIA CHANNEL ON ANY ARIA COMPATIBLE FIXTURE, MAKE SURE THE SOURCE ARIA TRANSCIEVER DEVICE IS OFF.**

With this feature you are able to control the unit with DMX without the use of XLR cables. Your DMX controller must be connected to a Aria Transceiver to use this function. Effective range is up to 2500 feet/760 meters (open line of sight).

1. Ensure the source Aria Transceiver device is powered OFF.
2. Power ON the fixture and using the control panel scroll to the PERSONALITY menu and press ENTER. Use the UP and DOWN buttons to highlight the ARIA SETTINGS submenu and press ENTER.
3. Using the UP and DOWN buttons, highlight FREQUENCY and then press ENTER. Use the UP and DOWN buttons to scroll through the available Aria frequency settings, then press ENTER to select the one that you would like to use.
4. Next select one of the two Aria channel settings (select 2.4 GHz Ch if you are using the 2.4 GHz frequency, or Sub Gig Ch if you are using either of the Sub Gig frequencies), then press ENTER. Use the UP and DOWN buttons to find your desired Aria channel and press ENTER to confirm.  
**NOTE:** Erratic fixture movement may occur if other Aria products are in use in the same area and are using the same Aria channel. When Aria is enabled, the fixture may immediately start to respond to the signal from another Aria Transceiver. Make sure to know what Aria channels are being used in the area where the fixture is being used.
5. Set your desired DMX address in the DMX ADDRESS submenu of the DMX SETTINGS main system menu. Set your desired DMX channel mode in the DMX CHANNEL MODE submenu of the DMX SETTINGS main system menu.
6. Repeat this process for all Aria compatible fixtures in the network, making sure all fixtures are assigned the same Aria channel.
7. After all fixtures in the Aria network have been set to the same Aria channel and powered ON, power ON the source AriaTransceiver device.
8. Test all fixtures connected to the Aria network to confirm proper functionality.

# ARIA SETUP

## INSTALLATION GUIDELINES

For best results, position the fixture so that the display screen is oriented in the direction of the transmitter device or remote.

Aria signal can penetrate walls, glass, metal, and most objects. However, there are many factors that can effect and/or interrupt the signal, including people. Therefore, it is highly recommended to position the wireless antenna a minimum of 9.8ft (3m) above audiences to ensure optimum and reliable operation.

**9.8 ft (3m)  
Above Ground**

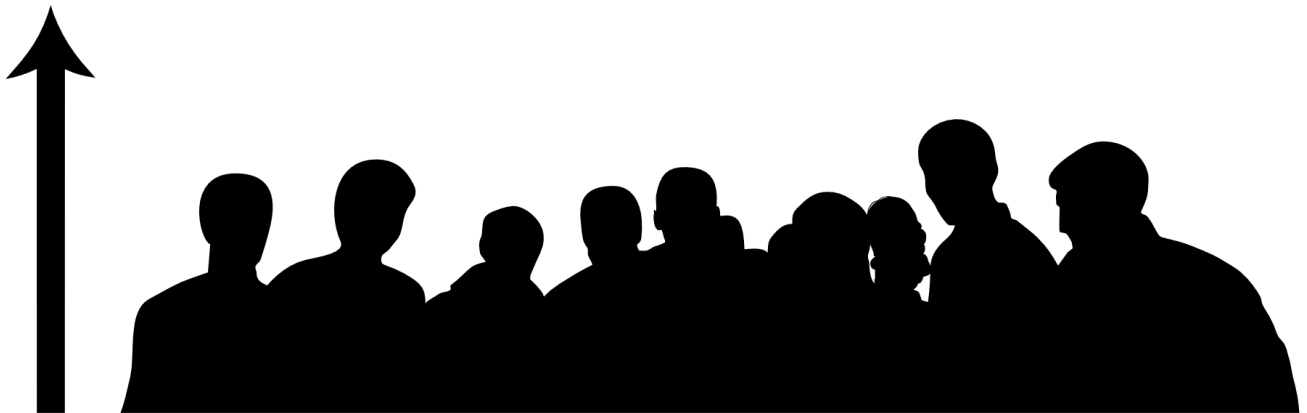



# DIMMER CURVE

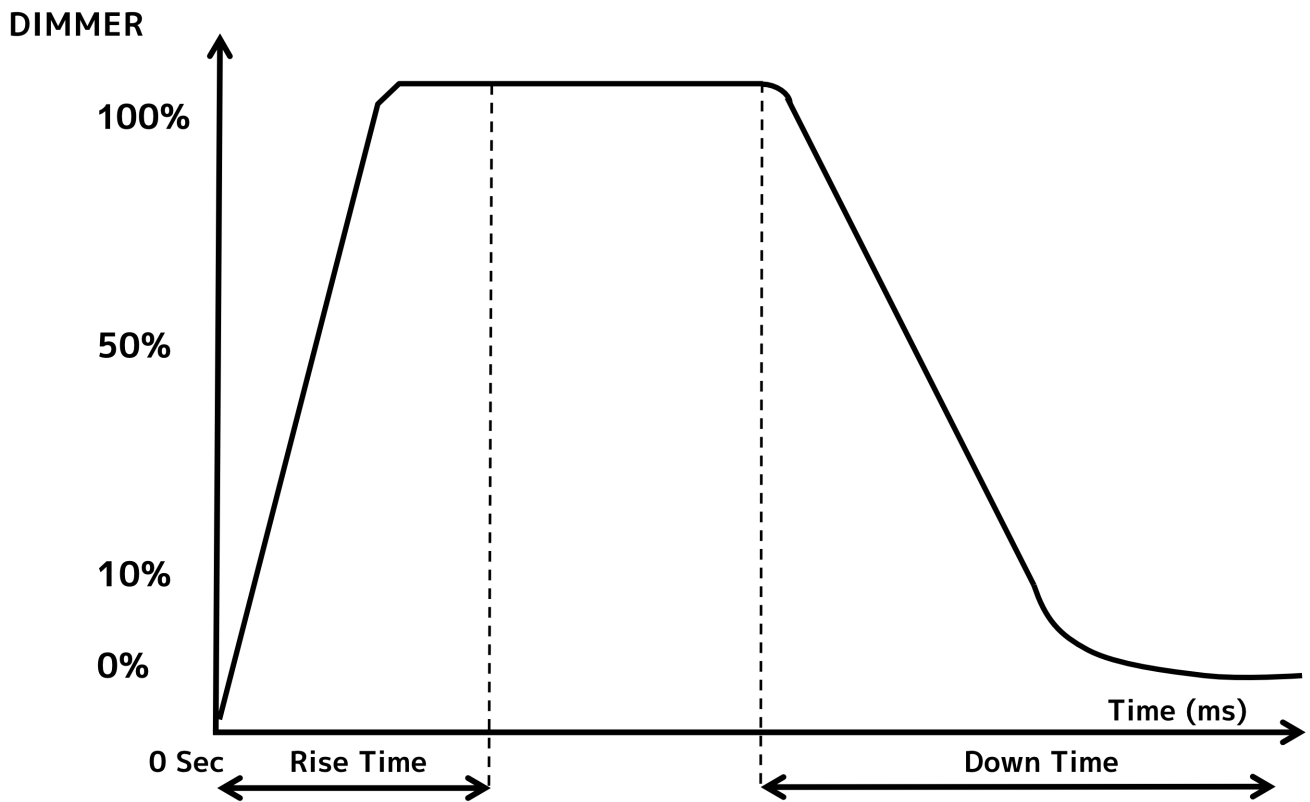

Dimming Curve Ramp Effect	0 sec Fade Time		1 sec Fade Time	
	Rise Time (ms)	Down Time (ms)	Rise Time (ms)	Down Time (ms)
Standard (default)	0	0	0	0
Stage	780	1100	1540	1660
TV	1180	1520	1860	1940
Architectural	1380	1730	2040	2120
Theatre	1580	1940	2230	2280

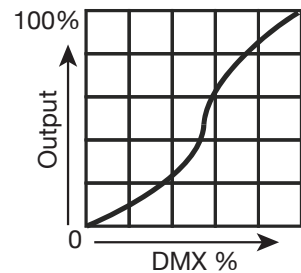
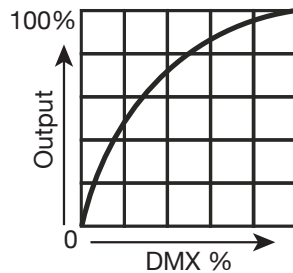
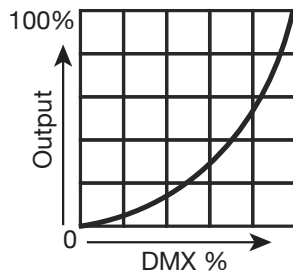
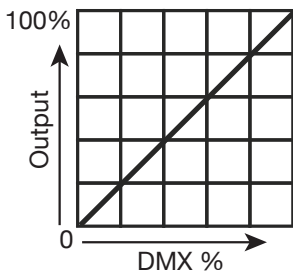

# DMX TRAITS: CHANNEL FUNCTIONS & VALUES

Basic	Std	Ext 3	Ext 5	Ext 7	Std RGBW	Std. CMY	Ext. CMY	Values	Functions
1	1	1	1	1	1	1	1	000-255	PAN 8bit 540/630 Degrees
	2	2	2	2	2	2	2	000-255	PAN FINE 16bit
2	3	3	3	3	3	3	3	000-255	TILT 8bit 270 Degrees
	4	4	4	4	4	4	4	000-255	TILT FINE 16bit
3	5				5			000-255	RED 0% - 100%
4	6				6			000-255	GREEN 0% - 100%
5	7				7			000-255	BLUE 0% - 100%
6	8				8			000-255	LIME 0% - 100%
		5	5	5				000-255	RED 1 0% - 100%
		6	6	6				000-255	GREEN 1 0% - 100%
		7	7	7				000-255	BLUE 1 0% - 100%
		8	8	8				000-255	LIME 1 0% - 100%
		...	...	...				000-255	...
		13	21	29				000-255	RED 7 0% - 100%
		14	22	30				000-255	GREEN 7 0% - 100%
		15	23	31				000-255	BLUE 7 0% - 100%
		16	24	32				000-255	LIME 7 0% - 100%
						5	5	000-255	CYAN (0-100% Cyan)
							6	000-255	CYAN FINE
						6	7	000-255	MAGENTA (0-100% Magenta)
							8	000-255	MAGENTA FINE
						7	9	000-255	YELLOW (0-100% Yellow)
							10	000-255	YELLOW FINE
	9	17	25	33	9	8	11	000-255	COLOR TEMPERATURE LINEAR 2,700-10,000K
7	10	18	26	34	10	9	12		COLOR TEMPERATURE PRESETS
								0	No Function
								001-060	2700K
								061-179	3000K
								180-201	3200K
								202-207	4000K
								208-229	4500K
								230-234	5000K
								235-239	5600K
								240-244	6500K
								245-249	8000K
								250-255	10000K
									<b>VIRTUAL FOREGROUND COLOR WHEEL</b>
								0	Open
								001-060	Virtual Swatch Colors (See Colors Tab)
								061-179	Open
								180-201	Color Scroll Clockwise, Fast -> slow
								202-207	Stop
								208-229	Color Scroll Counter-clockwise, Slow -> fast
								230-234	Open
								235-239	Random Slots Fast
								240-244	Random Slots Medium
								245-249	Random Slots Slow
								250-255	Open
									<b>VIRTUAL BACKGROUND COLOR WHEEL</b>
								0	Open
								001-060	Virtual Swatch Colors (See Colors Tab)
								061-179	Open
								180-201	Color Scroll Clockwise, Fast -> slow
								202-207	Stop
								208-229	Color Scroll Counter-clockwise, Slow -> fast
								230-234	Open
								235-239	Random Slots Fast
								240-244	Random Slots Medium
								245-249	Random Slots Slow
								250-255	Open

continued on next page

# DMX TRAITS: CHANNEL FUNCTIONS & VALUES

Basic	Std	Ext 3	Ext 5	Ext 7	Std RGBW	Std. CMY	Ext. CMY	Values	Functions
		21	29	37	13	12	15		<b>COLOR TEMPERATURE RED to GREEN</b>
								0	No Function
								001-255	Shift CT Red to Green
8	13	22	30	38	14	13	16	000-255	<b>64 COLOR MACROS (See Color Macros Chart)</b>
									<b>SHUTTER</b>
								000-031	Shutter Closed (LEDs OFF)
								032-063	Shutter OPEN (LEDs ON)
								064-095	Strobe effect slow to fast
9	14	23	31	39	15	14	17	096-127	Shutter OPEN (LEDs ON)
								128-159	Pulse effect in sequences
								160-191	Shutter OPEN (LEDs ON)
								192-223	Random strobe effect slow to fast
								224-255	Shutter OPEN (LEDs ON)
10	15	24	32	40	16	15	18	000-255	<b>DIMMER 0 to 100%</b>
	16	25	33	41	17	16	19	000-255	<b>DIMMER FINE 16bit</b>
11	17	26	34	42	18	17	20	000-255	<b>ZOOM Zoom adjustment from wide to narrow</b>
	18	27	35	43	19	18	21	000-255	<b>ZOOM FINE 16bit</b>
									<b>DIM MODES</b>
								000-020	Default to Unit Setting
								021-040	Standard
								041-060	Stage
								061-080	TV
								081-100	Architectural
								101-120	Theatre
								121-140	Stage 2
									<b>DIMMING SPEED</b>
								141	0.1 s
								142	0.2 s
								143	0.3 s
								144	0.4 s
								145	0.5 s
	19	28	36	44	20	19	22	146	0.6 s
								147	0.7 s
								148	0.8 s
								149	0.9 s
								150	1 s
								151	1.5 s
								152	2 s
								153	3 s
								154	4 s
								155	5 s
								156	6 s
								157	7 s
								158	8 s
								159	9 s
								160	10 s
								161-255	Default to Unit Setting
									<b>DIM CURVES</b>
								000-020	Square
								021-040	Linear
								041-060	Inv. Squa
								061-080	S. Curve
								081-255	No Function

continued on next page

# DMX TRAITS: CHANNEL FUNCTIONS & VALUES

Basic	Std	Ext 3	Ext 5	Ext 7	Std RGBW	Std. CMY	Ext. CMY	Values	Functions
									<b>INTERNAL PROGRAMS</b>
								000-009	No Function
								010-019	Program 1
								020-029	Program 2
								030-039	Program 3
								040-049	Program 4
								050-059	Program 5
								060-069	Program 6
								070-079	Program 7
								080-089	Program 8
								090-099	Program 9
12	21	30	38	46	22	21	24	100-109	Program 10
								110-119	Program 11
								120-129	Program 12
								130-139	Program 13
								140-149	Program 14
								150-159	Program 15
								160-169	Program 16
								170-179	Program 17
								180-189	Program 18
								190-199	Program 19
								200-209	Program 20
								210-255	No Function
13	22	31	39	47	23	22	25	000-255	<b>PROGRAM SPEED</b> Slow -> Fast
14	23	32	40	48	24	23	26	000-255	<b>PROGRAM FADE</b> Min. to Max.
15	24	33	41	49	25	24	27	000-255	<b>PAN / TILT SPEED</b> Max. to Min.
									<b>SPECIAL FUNCTION</b>
								000-010	No function (Default LED Refresh Rate 1200 Hz)
								011-011	900 Hz LED Refresh Rate
								012-012	910 Hz LED Refresh Rate
								013-013	920 Hz LED Refresh Rate
								014-014	930 Hz LED Refresh Rate
								015-015	940 Hz LED Refresh Rate
								016-016	950 Hz LED Refresh Rate
								017-017	960 Hz LED Refresh Rate
								018-018	970 Hz LED Refresh Rate
								019-019	980 Hz LED Refresh Rate
								020-020	990 Hz LED Refresh Rate
								021-021	1000 Hz LED Refresh Rate
								022-022	1010 Hz LED Refresh Rate
								023-023	1020 Hz LED Refresh Rate
16	25	34	42	50	26	25	28	024-024	1030 Hz LED Refresh Rate
								025-025	1040 Hz LED Refresh Rate
								026-026	1050 Hz LED Refresh Rate
								027-027	1060 Hz LED Refresh Rate
								028-028	1070 Hz LED Refresh Rate
								029-029	1080 Hz LED Refresh Rate
								030-030	1090 Hz LED Refresh Rate
								031-031	1100 Hz LED Refresh Rate
								032-032	1110 Hz LED Refresh Rate
								033-033	1120 Hz LED Refresh Rate
								034-034	1130 Hz LED Refresh Rate
								035-035	1140 Hz LED Refresh Rate
								036-036	1150 Hz LED Refresh Rate
								037-037	1160 Hz LED Refresh Rate
								038-038	1170 Hz LED Refresh Rate
								039-039	1180 Hz LED Refresh Rate

continued on next page

# DMX TRAITS: CHANNEL FUNCTIONS & VALUES

Basic	Std	Ext 3	Ext 5	Ext 7	Std RGBW	Std. CMY	Ext. CMY	Values	Functions
									<b>SPECIAL FUNCTION</b> (continued)
								040-040	1190 Hz LED Refresh Rate
								041-041	1210 Hz LED Refresh Rate
								042-042	1220 Hz LED Refresh Rate
								043-043	1230 Hz LED Refresh Rate
								044-044	1240 Hz LED Refresh Rate
								045-045	1250 Hz LED Refresh Rate
								046-046	1260 Hz LED Refresh Rate
								047-047	1270 Hz LED Refresh Rate
								048-048	1280 Hz LED Refresh Rate
								049-049	1290 Hz LED Refresh Rate
								050-050	1300 Hz LED Refresh Rate
								051-051	1310 Hz LED Refresh Rate
								052-052	1320 Hz LED Refresh Rate
								053-053	1330 Hz LED Refresh Rate
								054-054	1340 Hz LED Refresh Rate
								055-055	1350 Hz LED Refresh Rate
								056-056	1360 Hz LED Refresh Rate
								057-057	1370 Hz LED Refresh Rate
								058-058	1380 Hz LED Refresh Rate
								059-059	1390 Hz LED Refresh Rate
								060-060	1400 Hz LED Refresh Rate
								061-061	1410 Hz LED Refresh Rate
								062-062	1420 Hz LED Refresh Rate
								063-063	1430 Hz LED Refresh Rate
								064-064	1440 Hz LED Refresh Rate
								065-065	1450 Hz LED Refresh Rate
16	25	34	42	50	26	25	28	066-066	1460 Hz LED Refresh Rate
								067-067	1470 Hz LED Refresh Rate
								068-068	1480 Hz LED Refresh Rate
								069-069	1490 Hz LED Refresh Rate
								070-070	1500 Hz LED Refresh Rate
								071-071	2500 Hz LED Refresh Rate
								072-072	4000 Hz LED Refresh Rate
								073-073	5000 Hz LED Refresh Rate
								074-074	6000 Hz LED Refresh Rate
								075-075	10K Hz LED Refresh Rate
								076-076	15K Hz LED Refresh Rate
								077-077	20K Hz LED Refresh Rate
								078-078	25K Hz LED Refresh Rate
								079-079	No Function
								080-089	Enable Blackout while Pan/Tilt moving
								090-099	Disable Blackout while Pan/Tilt moving
								100-105	Fan Mode Low (Hold 3s)
								106-111	Fan Mode High (Hold 3s)
								112-117	Fan Mode Auto (Hold 3s)
								118-122	Enable Pan Invert (Hold 3s)
								123-127	Disable Pan Invert (Hold 3s)
								128-132	Enable Tilt Invert (Hold 3s)
								133-139	Disable Tilt Invert (Hold 3s)
								140-149	Reset All
								150-159	Reset Pan/Tilt
								160-169	Reset Effect
								170-174	Enable Zoom Speed Fast
								175-179	Disable Zoom Speed Fast
								180-182	Enable White Calibration (Hold 3s)
								183-185	Enable White Fixed Values (Hold 3s)

# DMX TRAITS: CHANNEL FUNCTIONS & VALUES

Basic	Std	Ext 3	Ext 5	Ext 7	Std RGBW	Std. CMY	Ext. CMY	Values	Functions
16	25	34	42	50	26	25	28		<b>SPECIAL FUNCTION</b> (continued)
								186-189	Fan Mode Mute (hold 3s)
								190-193	Enable Zoom Mode 2 (hold 3s)
								194-197	Disable Zoom Mode 2 (hold 3s)
								198-255	No Function

# PIXEL MAP

Extended 50 Pixel Configuration

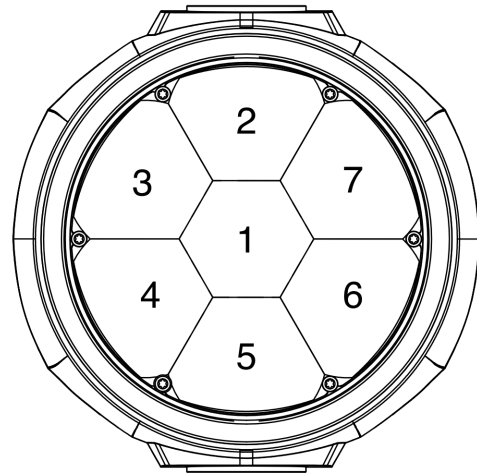

Extended 42 Pixel Configuration

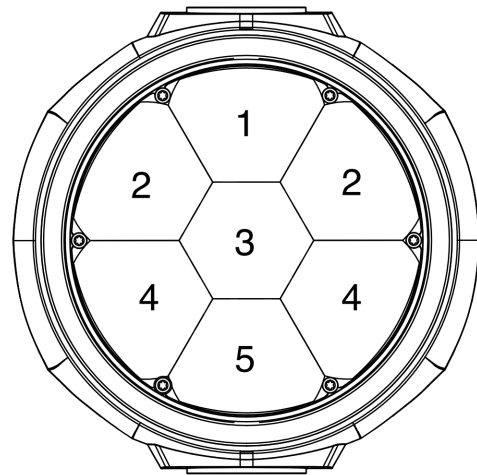

Extended 34 Pixel Configuration

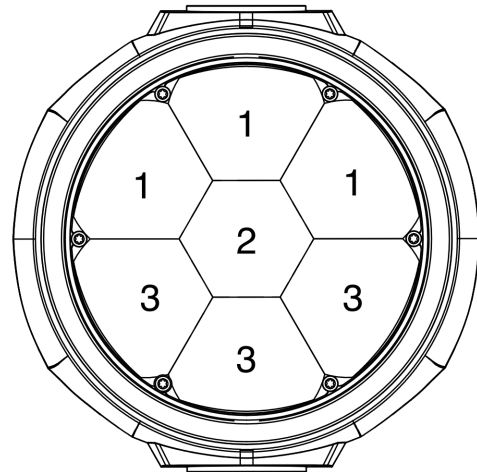

# ERROR CODES

Print Error Message	Description
Error code	PAN, TILT, Zoom, LED Temp, Base Temp, Head Fan, Base Fan

## POWER LINKING

This feature allows multiple units to be linked together by way of the power input and output sockets. The maximum number of devices that can be connected in this manner is as follows:

- **2 units @110v**
- **6 units @ 220v**

After this quantity has been reached, a new power outlet must be used to accommodate additional devices.

**Linked devices must be of the same make and model type. DO NOT mix devices!**

## CLEANING

Due to fog residue, smoke, and dust cleaning the internal and external optical lenses must be carried out periodically to optimize light output.

1. Use normal glass cleaner and a soft cloth to wipe down the outside casing.
2. Clean the external optics with glass cleaner and a soft cloth every 20 days.
3. Always be sure to dry all parts completely before plugging the unit back in.

Cleaning frequency depends on the environment in which the fixture operates (i.e. smoke, fog residue, dust, dew).



# SPECIFICATIONS

## Source:

- 7 x 40-Watt RGLB LEDs (50,000 hr.)
- CRI: 83.4
- CT: 2700K ~ 10,000K
- 14,329 lux / 4° beam @ 16' (5m)
- 367 lux / 35° beam @ 16' (5m)
- Lumens: 3500 (Zoomed Out, Full On)

## Features:

- Moving Head Pixel Wash with Pixel Effects
- Electronic Strobe / Dimmer
- Pan/Tilt: 540/630 x 265/230
- Beam Angle: 4 ~ 35°
- Field Angle: 6 ~ 55°
- Color Calibrated Pixels so units match from batch to batch
- Virtual CMY DMX Control Modes
- Virtual Foreground and Background Color Wheel Control
- Selectable LED Refresh Rates (900 Hz~25K Hz)
- Selectable Dim Modes: Standard, Stage, TV, Arch., Theatre, Stage 2 and user settable Dim Speed (0.1S~10S)
- 4 Dim Curves: Square, Linear, Inv. Square and S. Curve
- 0-100% smooth dimming
- Various strobe speeds
- USB firmware update port
- Fan Cooled
- Antenna for WiFLY EXR Wireless DMX

## Colors:

- Virtual CMY DMX Control Modes
- Virtual Foreground and Background Color Wheel Control
- Built-In Color Macros
- 2,700K ~ 10,000K Linear White Color Temperature Control
- Color Temperature Presets: 2,700, 3,000, 3,200, 4,000, 4,500, 5,000, 5,600, 6,500, 8,000 and 10,000K

## Control:

- 8 DMX Modes - 16/25/34/42/50/26 (RGBW)/25 (CMY)/28 (CMY) Channels
- Color LCD display with 6-button function menu
- Control Mode: DMX512 or internal programs
- Built-In Effect Pixel Programs with Speed and Fade Control
- Various strobe speeds
- USB firmware update port
- With Wired Digital Communication Network
- RDM (Remote Device Management)
- WiFLY EXR Wireless DMX built-in (2500 ft. / 700M line of sight). Also compatible with Aria X2 Transceivers for 2.4Ghz Wireless DMX control.

## Pan/Tilt:

- Pan: 540/630 degrees
- Tilt: 250 degrees

## Connections:

- DMX Connections: 5-pin XLR In/Out
- Power Connections: Indoor Locking Power In/Out

## Electrical:

- Multi-voltage operation: 90-240V, 50/60Hz
- Max power consumption: 337W @120V

## Dimensions & Weight:

- Dimensions (LxWxH): 7.0"x9.8"x13.7" (178.8x250.0x349.2mm)
- Weight: 15.5lbs (7kg)

## What's Included:

- Omega Brackets
- 1.83M locking power cable
- Safety Cable

## Approvals / Rating:

- cETLus Approved
- CE Certified
- IP20



# DIMENSIONS

Drawings not to scale.

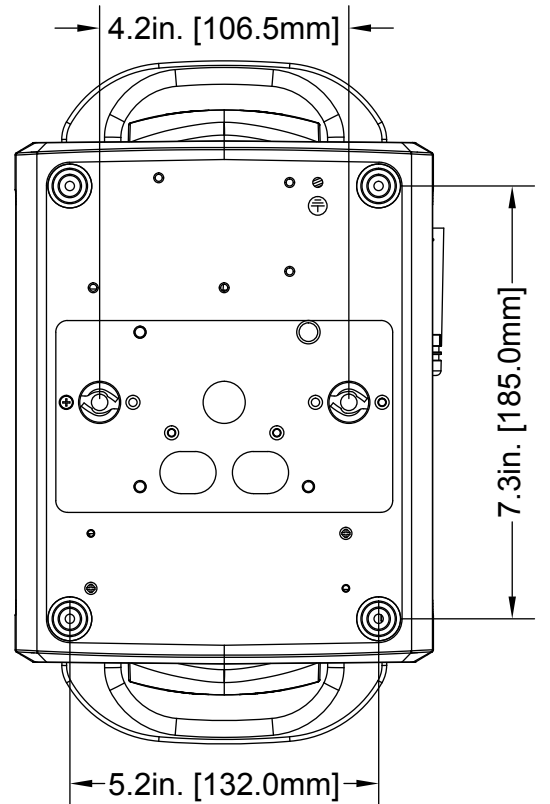
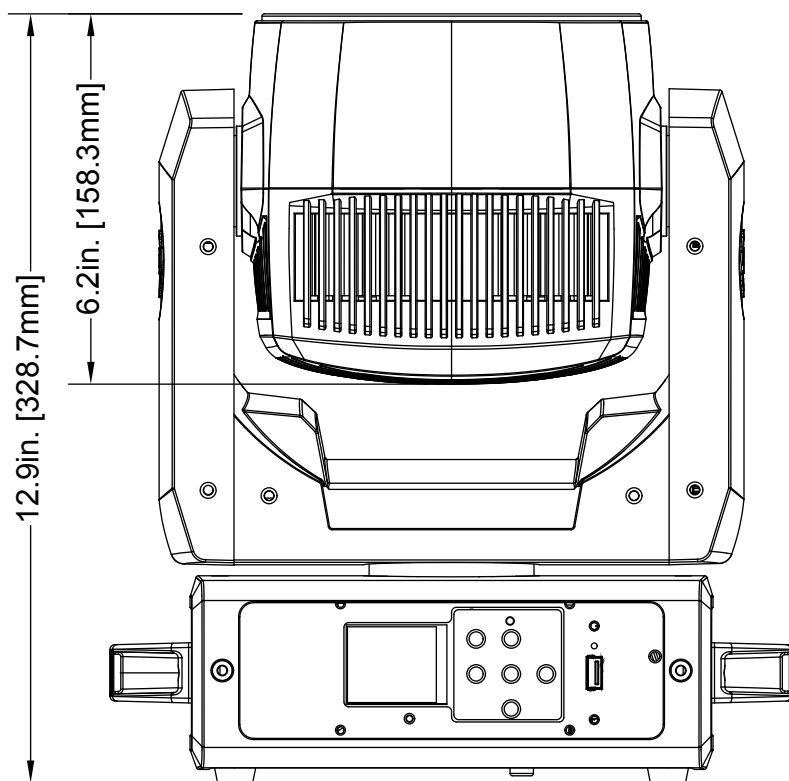
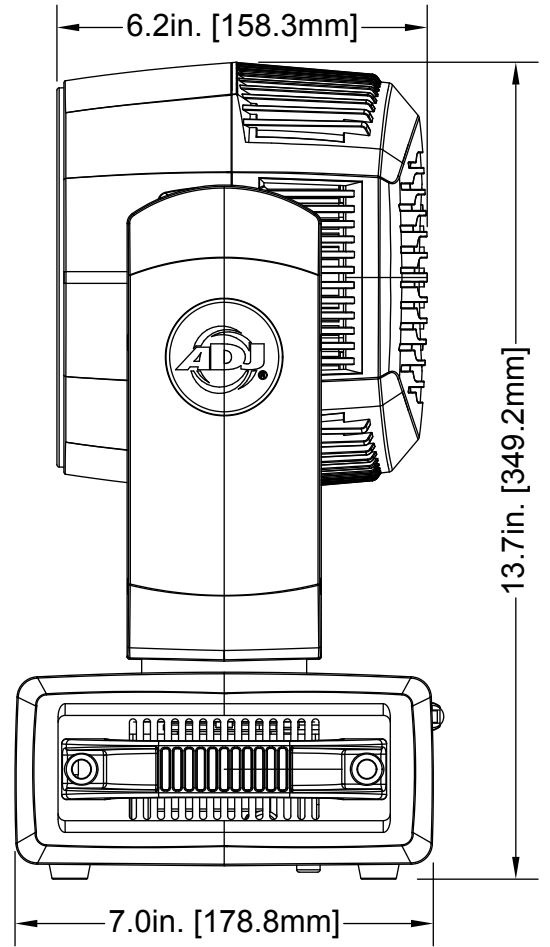
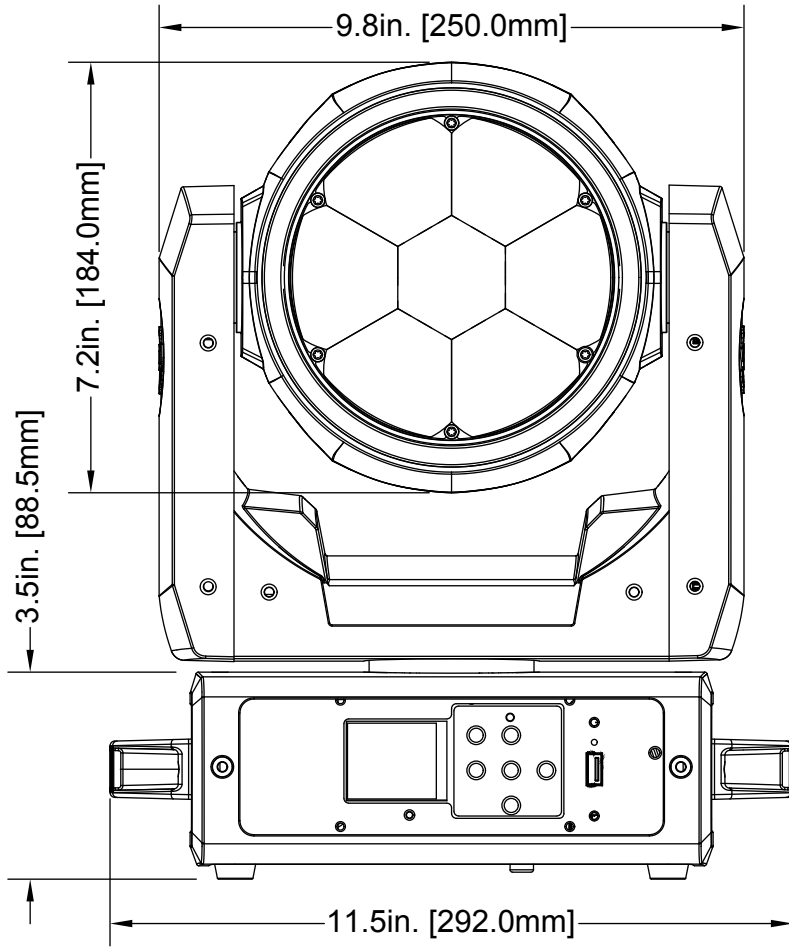

*This page intentionally left blank.*

