



MIRAGE Q IP



User Manual

©2024 ADJ Products, LLC all rights reserved. Information, specifications, diagrams, images, and instructions herein are subject to change without notice. ADJ Products, LLC logo and identifying product names and numbers herein are trademarks of ADJ Products, LLC. Copyright protection claimed includes all forms and matters of copyrightable materials and information now allowed by statutory or judicial law or hereinafter granted. Product names used in this document may be trademarks or registered trademarks of their respective companies and are hereby acknowledged. All non-ADJ Products, LLC brands and product names are trademarks or registered trademarks of their respective companies.

ADJ Products, LLC and all affiliated companies hereby disclaim any and all liabilities for property, equipment, building, and electrical damages, injuries to any persons, and direct or indirect economic loss associated with the use or reliance of any information contained within this document, and/or as a result of the improper, unsafe, insufficient and negligent assembly, installation, rigging, and operation of this product.

DOCUMENT VERSION



Due to additional product features and/or enhancements, an updated version of this document may be available online.

Please check www.adj.com for the latest revision/update of this manual before beginning installation and/or programming.

Date	Document Version	Software Version	DMX Channels	Notes
09/08/2022	1.0	V1.04	4 / 6 / 7 / 8 / 9A / 9B / 10 / 11 / 12 / 15 / 18 channels	Initial Release
05/19/2023	1.1	V2.01	No Change	Updated IR Remote, System Menu, DMX Traits, Specifications; changed Wireless to wireless
01/17/2024	1.2	N/C	No Change	
03/14/2024	1.2	N/C	No Change	ETL Approved

Europe Energy Saving Notice

Energy Saving Matters (EuP 2009/125/EC)

Saving electric energy is a key to help protecting the environment. Please turn off all electrical products when they are not in use. To avoid power consumption in idle mode, disconnect all electrical equipment from power when not in use. Thank you!

TABLE OF CONTENTS

General Information	4
Key Features Warranty Returns	5
Limited Warranty (USA Only)	6
Safety Guidelines	7
Overview	8
DMX Addressing	9
Wireless Setup	10
UC IR Remote	12
Installation	13
Control Panel	17
System Menu	18
DMX Traits	21
Color Macros	35
IR Default RGBA Values	36
Color Temperature	37
Dimmer Curves	38
Cleaning & Maintenance	39
Torque Settings	40
Battery Life	41
Dimensional Drawings	42
Specifications	43

GENERAL INFORMATION

Introduction: Congratulations on your purchase of the ADJ Mirage Q IP! This device is battery-operated, IP65-rated, RGBA LED chrome upright, and has been designed to perform reliably for years when the guidelines in this booklet are followed. Please read and understand the instructions in this manual carefully and thoroughly before attempting to operate the device. These instructions contain important information regarding safety during use and maintenance.

Please keep this manual with the device for future reference.

Customer Support: Contact ADJ Service for any product related service and support needs. Also visit forums.adj.com with questions, comments or suggestions.

Parts: To purchase parts online visit:

<http://parts.adj.com> (US)

<http://www.adjparts.eu> (EU)

ADJ SERVICE USA - Monday - Friday 8:00am to 4:30pm PST

Voice: 800-322-6337 | Fax: 323-582-2941 | support@adj.com

ADJ SERVICE EUROPE - Monday - Friday 08:30 to 17:00 CET

Voice: +31 45 546 85 60 | Fax: +31 45 546 85 96 | support@adj.eu

ADJ PRODUCTS LLC USA

6122 S. Eastern Ave. Los Angeles, CA. 90040

323-582-2650 | Fax 323-532-2941 | www.adj.com | info@adj.com

ADJ SUPPLY Europe B.V

Junostraat 2 6468 EW Kerkrade, The Netherlands

+31 (0)45 546 85 00 | Fax +31 45 546 85 99

www.americandj.eu | info@americandj.eu

ADJ PRODUCTS GROUP Mexico

AV Santa Ana 30 Parque Industrial Lerma, Lerma, Mexico 52000

+52 (728) 282-7070

WARNING! To prevent or reduce the risk of electrical shock or fire, do not expose the charging flight case to rain or moisture.

CAUTION! There are no user serviceable parts inside these units. Do not attempt any repairs yourself, as doing so will void your manufacturer's warranty. In the unlikely event your unit may require service, please contact ADJ Products, LLC.

Do not discard the shipping carton in the trash. Please recycle when ever possible.

KEY FEATURES

FIXTURE FEATURES

- IP65 Outdoor Rated
- 15 Degree Beam Angle
- 4-touch button OLED display on rear panel
- Built-in wireless DMX: Up to 2,500 feet (760M) when used with ADJ's wireless Battery Transceiver
- 64 built-in Color Macros
- Flicker Free Operation
- Electronic Dimming: 0 - 100% with 6 dim modes and 4 dim curves
- Rechargeable Lithium-Ion Battery
- Battery Charge Time: 7 Hours
- Battery Life: 40 hours (single color)
- Motion-Activated Alarm Feature
- Kensington Key Slot

IP RATING

An IP rated lighting fixture is commonly installed in outdoor environments and has been designed with an enclosure that effectively protects the ingress (entry) of external foreign objects such as dust and water. The Ingress Protection (IP) rating system is commonly expressed as "IP" followed by two numbers (i.e. IP65), where the numbers define the degree of protection. The first digit (Foreign Bodies Protection) indicates the extent of protection against particles entering the fixture and the second digit (Water Protection) indicates the extent of protection against water entering the fixture. **An IP65 rated lighting fixture, such as this one, has been designed and tested to protect against the ingress of dust (6) and low-pressure water jets from any direction (5).**

PLEASE NOTE: The charging base is NOT rated for protection against moisture or dust intrusion of any kind, and should be used in dry indoor environments only!

WARRANTY RETURNS

All returned service items, whether under warranty or not, must be freight pre-paid and accompanied by a return authorization (R.A.) number. The R.A. number must be clearly written on the outside of the return package. A brief description of the problem as well as the R.A. number must also be written down on a piece of paper included in the shipping carton. If the unit is under warranty, you must provide a copy of your proof of purchase invoice. You may obtain an R.A. number by contacting our customer support team. All packages returned to the service department not displaying an R.A. number on the outside of the package will be returned to the shipper.

LIMITED WARRANTY (USA ONLY)

- A. ADJ Products, LLC hereby warrants, to the original purchaser, ADJ Products, LLC products to be free of manufacturing defects in material and workmanship for a prescribed period from the date of purchase (see specific warranty period on reverse). This warranty shall be valid only if the product is purchased within the United States of America, including possessions and territories. It is the owner's responsibility to establish the date and place of purchase by acceptable evidence, at the time service is sought.
- B. For warranty service, you must obtain a Return Authorization number (RA#) before sending the product back—please contact ADJ Products, LLC Service Department at 800-322-6337. Send the product only to the ADJ Products, LLC factory. All shipping charges must be prepaid. If the requested repairs or service (including parts replacement) are within the terms of this warranty, ADJ Products, LLC will pay return shipping charges only to a designated point within the United States. If the entire instrument is sent, it must be shipped in its original package and packaging material. No accessories should be shipped with the product. If any accessories are shipped with the product, ADJ Products, LLC shall incur no liability whatsoever for loss of or damage to any such accessories, nor for the safe return thereof.
- C. This warranty is void if the product serial number and/or labels are altered or removed; if the product is modified in any manner which ADJ Products, LLC concludes, after inspection, affects the reliability of the product; if the product has been repaired or serviced by anyone other than the ADJ Products, LLC factory unless prior written authorization was issued to purchaser by ADJ Products, LLC; if the product is damaged because it was not properly maintained as set forth in the product instructions, guidelines and/or user manual.
- D. This is not a service contract, and this warranty does not include maintenance, cleaning, or periodic check-up. During the period specified above, ADJ Products, LLC will replace defective parts at its expense with new or refurbished parts, and will absorb all expenses for warranty service and repair labor by reason of defects in material or workmanship. The sole responsibility of ADJ Products, LLC under this warranty shall be limited to the repair of the product, or replacement thereof, including parts, at the sole discretion of ADJ Products, LLC. All products covered by this warranty were manufactured after August 15, 2012, and bear identifying marks to that effect.
- E. ADJ Products, LLC reserves the right to make changes in design and/or improvements upon its products without any obligation to include these changes in any products theretofore manufactured.
- F. No warranty, whether expressed or implied, is given or made with respect to any accessory supplied with products described above. Except to the extent prohibited by applicable law, all implied warranties made by ADJ Products, LLC in connection with this product, including warranties of merchantability or fitness, are limited in duration to the warranty period set forth above. And all warranties, whether expressed or implied, including warranties of merchantability or fitness, are limited in duration to the warranty period set forth above. The consumer's and/or dealer's sole remedy shall be such repair or replacement as is expressly provided above; and under no circumstances shall ADJ Product, LLC be liable for any loss and/or damage, direct and/or consequential arising out of the use of, and/or inability to use this product.
- G. This warranty is the only written warranty applicable to ADJ Products, LLC products, and supersedes all prior warranties and written descriptions of warranty terms and conditions heretofore published.

MANUFACTURER'S LIMITED WARRANTY PERIODS:

- Non-LED Lighting Products = 1-Year (365 Days) (Including Special Effect Lighting, Intelligent Lighting, UV lighting, Strobes, Fog Machines, Bubble Machines, Mirror Balls, Par Cans, Trussing, Lighting Stands, Power/Data Distribution, etc. excluding LED and lamps)
- Laser Products = 1-Year (365 Days) (excluding laser diodes which have a 6-Month Limited Warranty)
- LED Products = 2-Year (730 Days) (excluding batteries which have a 180 Day Limited Warranty)
- NOTE: 2-Year (730 Days) Limited Warranty ONLY applies to product purchased within the United States. StarTec Series = 1-Year (365 Days) (excluding batteries which have a 180 Day Limited Warranty)
- ADJ DMX Controllers = 2 Year (730 Days)
- American Audio Products = 1 Year (365 Days)

SAFETY GUIDELINES

For Your Own Personal Safety, Please Read and Understand This Manual Completely Before You Attempt To Install Or Operate This Unit!

- Be sure to save the packing carton for use in the event that the device needs to be returned to the manufacturer for service.
- Charging base is designed for use in dry indoor environments only! Do NOT expose to rain, dust, or moisture!
- Be sure that the voltage of the power source matches the required voltage for the device.
- Do not open up the device for any reason. There are no user serviceable parts inside.
- Disconnect the device's main power when left unused for long periods of time.
- Never connect this device to a dimmer pack.
- Do not attempt to operate this device if it has been damaged in any way.
- Never operate this device with the cover removed.
- Do not attempt to operate this device if the power cord has been frayed or broken.
- Do not attempt to remove or break off the ground prong from the electrical cord. This prong is used to reduce the risk of electrical shock and fire in case of an internal short.
- Disconnect from main power before making any type of connection.
- Never block the ventilation holes. Always be sure to mount this device in an area that will allow proper ventilation. Allow about 6" (15cm) between this device and a wall.
- Always mount this device in a safe and stable matter.
- Please route your power cord out of the way of foot traffic. Power cords should be routed so they are not likely to be walked on, or pinched by items placed upon or against them

Operating temperature range for this fixture is 32 to 113 degrees F (0 to 45 degrees C). Do not operate this device when ambient temperature falls outside this range!

Keep flammable materials away from this fixture!

The device should be serviced by qualified service personnel when:

- A. The power-supply cord or the plug has been damaged.
- B. Objects have fallen on, or liquid has been spilled into, the device.
- C. The appliance does not appear to operate normally or exhibits a marked change in performance.

SAFETY GUIDELINES

1. Remove and immediately recycle or dispose of used batteries according to local regulations and keep away from children. Do NOT dispose of batteries in household trash or incinerate.
2. Even used batteries may cause severe injury or death.
3. Call a local poison control center for treatment information.
4. This product contains a type CR2025 3V button cell.
5. The button cell is Non-rechargeable batteries are not to be recharged.
6. Do not force discharge, recharge, disassemble, heat above 60° or incinerate. Doing so may result in injury due to venting, leakage or explosion resulting in chemical burns.
7. Ensure the batteries are installed correctly according to polarity (+ and -).
8. Do not mix old and new batteries, different brands or types of batteries, such as alkaline, carbon-zinc, or rechargeable batteries.
9. Remove and immediately recycle or dispose of batteries from equipment not used for an extended period of time according to local regulations.
10. Always completely secure the battery compartment. If the battery compartment does not close securely, stop using the product, remove the batteries, and keep them away from children.

OVERVIEW

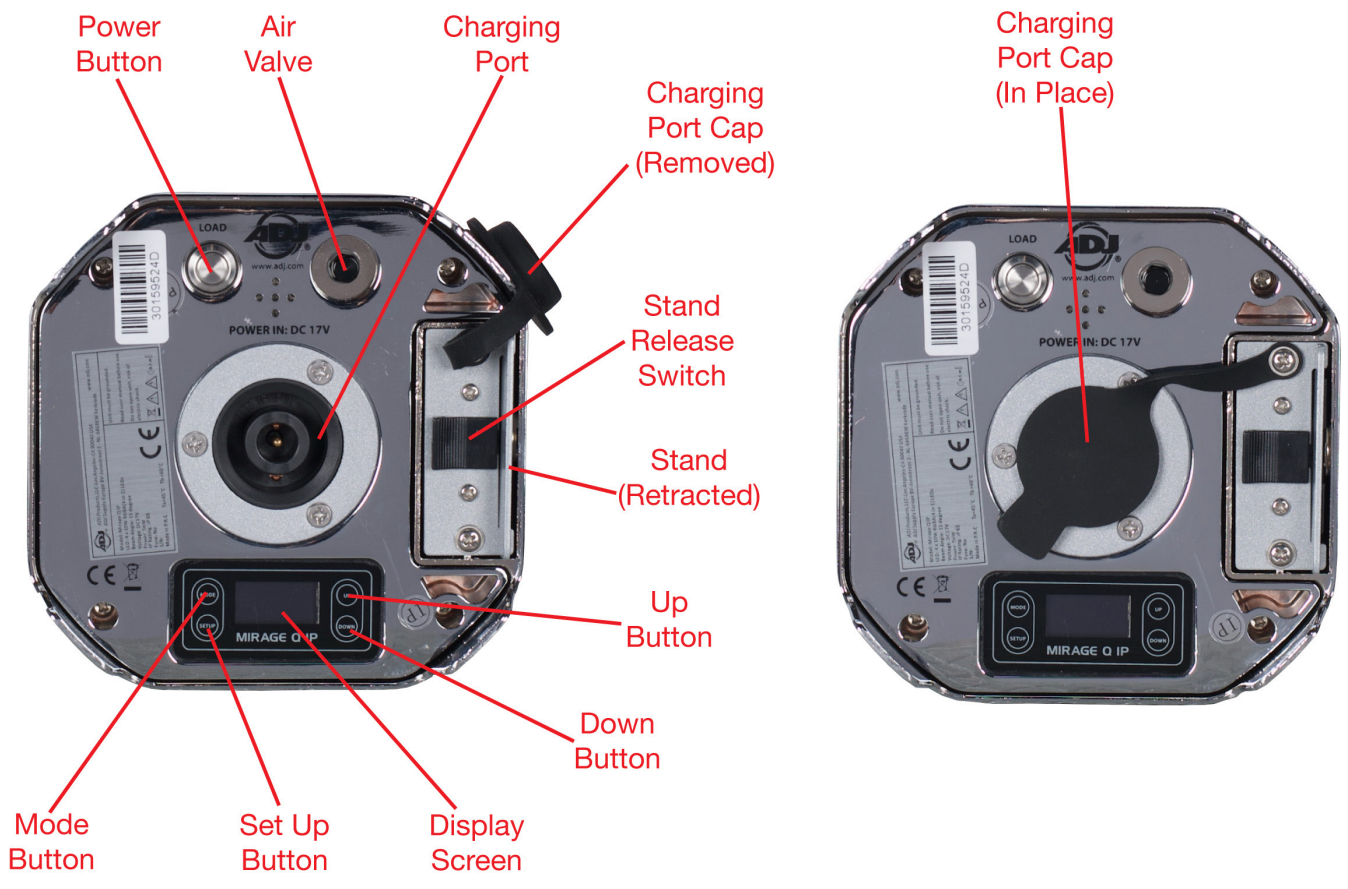

DMX ADDRESSING

All fixtures should be given a DMX starting address when operating with a DMX controller, in order to ensure that the correct fixture responds to the correct control signal. This digital starting address is the channel number from which the fixture starts to “listen” to the digital control signal sent out from the DMX controller. This starting DMX address is assigned by setting the correct DMX address on the digital control display on the fixture.

You can set the same starting address for all fixtures or a group of fixtures, or set different addresses for each individual fixture. Setting all fixtures to the same DMX address will cause all fixtures to react in the same way. In this case, please note that changing the settings of one channel will affect all the fixtures simultaneously.

If you set each fixture to a different DMX address, each unit will start to “listen” to the channel number you have set, based on the quantity of DMX channels of each fixture. That means changing the settings of one channel will only affect the selected fixture.

As an example, when operating this fixture model in 4 channel mode, you should set the starting DMX address of the first unit to 1, the second unit to 5 (4 + 1), the third unit to 9 (4 + 4 + 1), and so on. (See the chart below for more details.)

Channel Mode	Unit 1 Addr	Unit 2 Addr	Unit 3 Addr	Unit 4 Addr
4-Ch	1	5	9	13
6-Ch	1	7	13	19
7-Ch	1	8	15	22
8-Ch	1	9	17	25
9-Ch	1	10	19	28
10-Ch	1	11	21	31
11-Ch	1	12	23	34
12-Ch	1	13	25	37
15-Ch	1	16	31	46
18-Ch	1	19	37	55

WIRELESS SETUP

These devices do not feature physical DMX connector ports. Therefore, in order to utilize DMX control, the user must first set up the devices to run wireless DMX control. Follow the directions below to configure wireless DMX control:

1. First, select the DMX Channel Mode for that you would like the device to operate in. Press MODE until the the “DMX Settings” menu is displayed on the screen. Use the UP and DOWN buttons to scroll to “DMX Channel Mode,” then press the SETUP button.
2. Use UP and DOWN to scroll through the DMX Channel Mode options, then press SETUP to confirm your selection.
3. Next, enable the device’s wireless capability. Press MODE until the “Personality” menu is displayed on the screen, then use UP and DOWN to scroll to “Wireless Settings” and press SETUP.
4. Use UP and DOWN to scroll to “Enable Wireless,” then press SETUP to select this option.
5. Use UP and DOWN once again to toggle this setting to “Yes,” then confirm by pressing SETUP.
6. Next, select the Wireless channel. Press MODE until the “Personality” menu is displayed on the screen again, then use UP and DOWN to scroll to “Wireless Settings” and press SETUP.
7. Use UP and DOWN to scroll to “Set Wireless Channel,” then press SETUP again.
8. Now use UP and DOWN to scroll to your desired Wireless channel. Selectable values range from 00 to 15.
9. Finally, set the DMX address. Press the MODE button until the “DMX Settings” menu is displayed on the screen, then use UP and DOWN to scroll to “DMX Address,” then press SETUP.
10. Use the UP and DOWN buttons to scroll to your desired DMX address, then press SETUP to confirm your selection. Available values range from 001 to 512. Refer to the **DMX Addressing** section of this manual for detailed guidance. Repeat these steps for each individual unit that you wish to use.

WIRELESS SETUP

There are many factors that can affect and/or interrupt a wireless signal, including walls, glass, metal, objects, and people. Therefore, the following guidelines are recommended in order to maximize the chances of having a clear path for the wireless signal to reach the device:

- Install the device a minimum of 9.8 ft (3m) above audiences and/or ground level.
- Arrange the wireless antenna in an upright, vertical position.
- Position devices in direct line of sight of the transmitting controller.

Careful planning and testing of the selected installation location is critical to ensure optimum and reliable wireless operation.



IR REMOTE

The unit can only be controlled when it has been set to **Primary mode**. The unit will **NOT** respond to commands when it has been set to **Secondary mode**. When using the remote to control multiple units that are operating in primary/secondary mode, follow these steps to set up the units:

1. Power on the unit, and press MODE to scroll to the “Personality” menu.
2. Press SETUP, then use the UP and DOWN buttons to scroll to “Primary” or “Secondary” depending on the how you would like this unit to operate. Press SETUP to make your selection, and then use the UP and DOWN buttons to switch the option to ON.
3. Press SETUP to confirm and return to the “Personality” menu.
4. Use UP and DOWN to scroll to “Wireless Settings” and select “Set Wireless Channel.” Press SETUP and use UP and DOWN to set the unit to your desired Wireless channel. Repeat these steps for each unit. Please note that all units should be set to the same Wireless channel.

NOTES:

- Only one unit should be configured as the primary, while all the other units should be configured as secondaries.
- All units in the system should be set to the same wireless channel. If all units are set to the same wireless channel, and the units do not sync up and/or respond to commands, try using a different wireless channel.
- All units should be set to the same DMX channel mode.
- If fixtures fail to sync, verify that all settings mentioned above are the same, then power all devices off, then switch them on again to re-establish the link.

UC IR24 CONTROLS

- **On:** Fixture turns on and reverts to the last running state
- **Off:** Fixture goes into stand by mode in a blackout state.
- **Strobe:** Activates strobe mode. The strobe rate can be adjusted using the + / - buttons.
- **Sound:** This button has no defined function for this unit.
- **Color:** Activates color mode. Select a static color (0-15) using the number keys. The intensity for the set color can then be adjusted with the +/- buttons.
- **Program:** Activates program mode. Select an internal program (0-15) using the number keys. The selected program run speed can be adjusted with the +/- buttons. *Note: 13 of the 15 buttons will activate a program for this unit.*
- **+ and - buttons:** Adjusts strobe rate, mic sensitivity, intensity, or program run speed. The +/- buttons can be repeatedly pressed to increase or decrease by individual level increments, or pressed and held to quickly make large adjustments at once.
- **Number Keys (0-15):** These buttons are used to select preset static colors and internal programs. Colors stored in the number keys can be edited from the units menu if desired.



INSTALLATION

IP RATING

The Mirage Q IP is **IP65** rated. It is completely dust tight, and is protected against low-pressure directed jets of water from any direction. **Note that the charging base is NOT protected against moisture or dust intrusion of any kind, and should be used only in a dry, indoor setting!**

FLAMMABLE MATERIAL WARNING!

Keep device a minimum of 5.0 feet (1.5m) away from flammable material and/or pyrotechnics.

ELECTRICAL CONNECTIONS

A qualified electrician should be used for all electrical connections and/or installations.

DO NOT INSTALL THE DEVICE IF YOU ARE NOT QUALIFIED TO DO SO!

The unit **MUST** be installed following all local, national, and country commercial electrical and construction codes and regulations.

Before installing or mounting any device, a professional equipment installer **MUST** be consulted to determine whether the mounting structure or surface is properly certified to safely support the combined weight of the fixture, clamps, cables, and accessories.

Operating temperature range is **32 to 113 degrees F (0 to 45 degrees C)**. Do not operate the device if ambient temperatures fall outside of this range.

This fixture should be installed in areas outside walking paths, seating areas, and areas where unauthorized personnel might be able to reach the device by hand.

NEVER stand directly below the fixture when rigging, removing, or servicing.

Allow approximately 15 minutes for the fixture to cool down before servicing.

INSTALLATION

CLAMP INSTALLATION

The Mirage Q IP features a mounting clamp attachment point on the side of the device (see the illustration below). When mounting the fixture to a truss or any other suspended or overhead installation, be sure to secure appropriately rated clamps (not included) to the clamp attachment point.

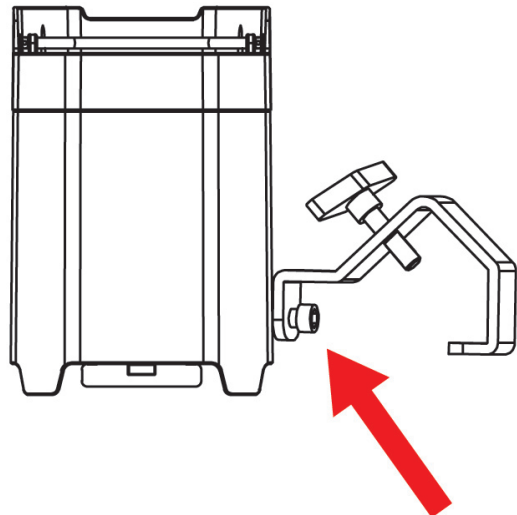

**MOUNTING CLAMP
ATTACHMENT POINT**

RIGGING

Overhead rigging requires extensive experience, including but not limited to: calculating working load limits, understanding the installation material being used, and periodic safety inspection of all installation material and the fixture itself. If you lack these qualifications, do not attempt to perform the installation yourself. Improper installation can result in bodily injury.

CHARGING PORT CAP

In order to maintain IP65 integrity, the charge port of each device must be sealed off using the attached rubber cap when the charging port is not in use.

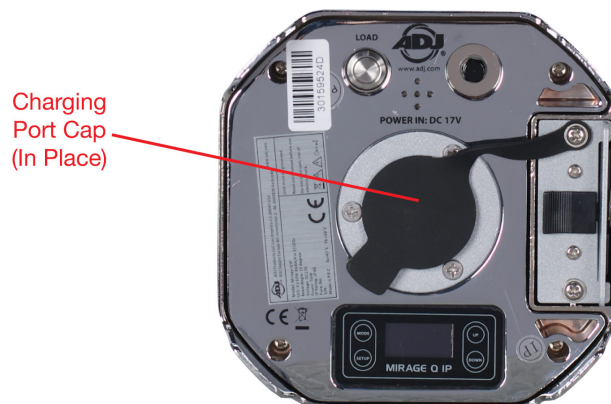

INSTALLATION

KICKSTAND FOR FLOOR PLACEMENT

The Mirage Q IP can also be placed on the floor to provide an uplighting display, and features a retractable kickstand that allows the device to be angled in the direction of the desired display. **Make sure that the rubber cap is secured over the charge port to maintain the device's IP65 rating.**

To deploy the kickstand, simply toggle the switch on the underside of the device, near the power charging port (1). The kickstand can then be deployed from the underside (2) at various notched increments, allowing a maximum angle of 35 degrees from the vertical axis (3).

Note: If set and activated, the alarm will be triggered by any movement of the device, including knocking over the device. The alarm will sound and the device will strobe red for the amount of time that was set in the "Alarm Time" setting, but will automatically stop when the device is returned to its place. Please be aware of this feature in the event that you decide to re-locate or re-position the device after the initial setup!

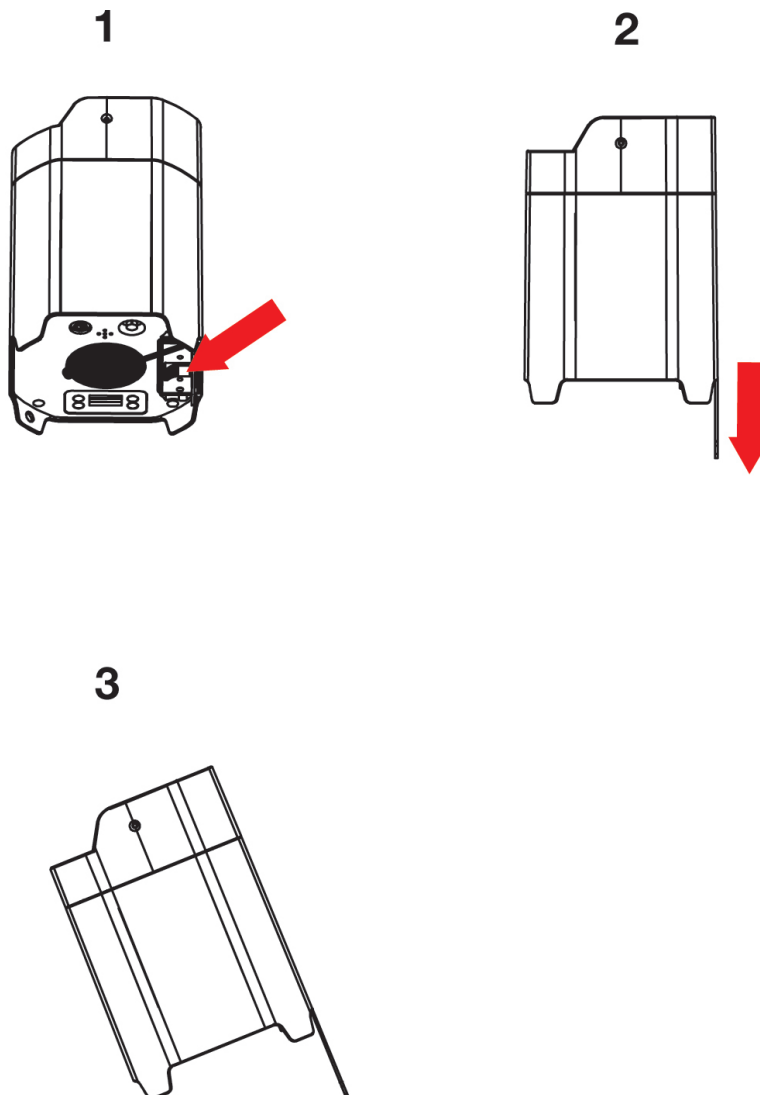

INSTALLATION

KENSINGTON KEY SLOT

The device features a slot for a Kensington-type security device that can be used to prevent theft. The key slot is located near the bottom of one of the device's feet, as shown in the illustration below. Be sure to attach the security device to a sturdy, fixed anchor point.

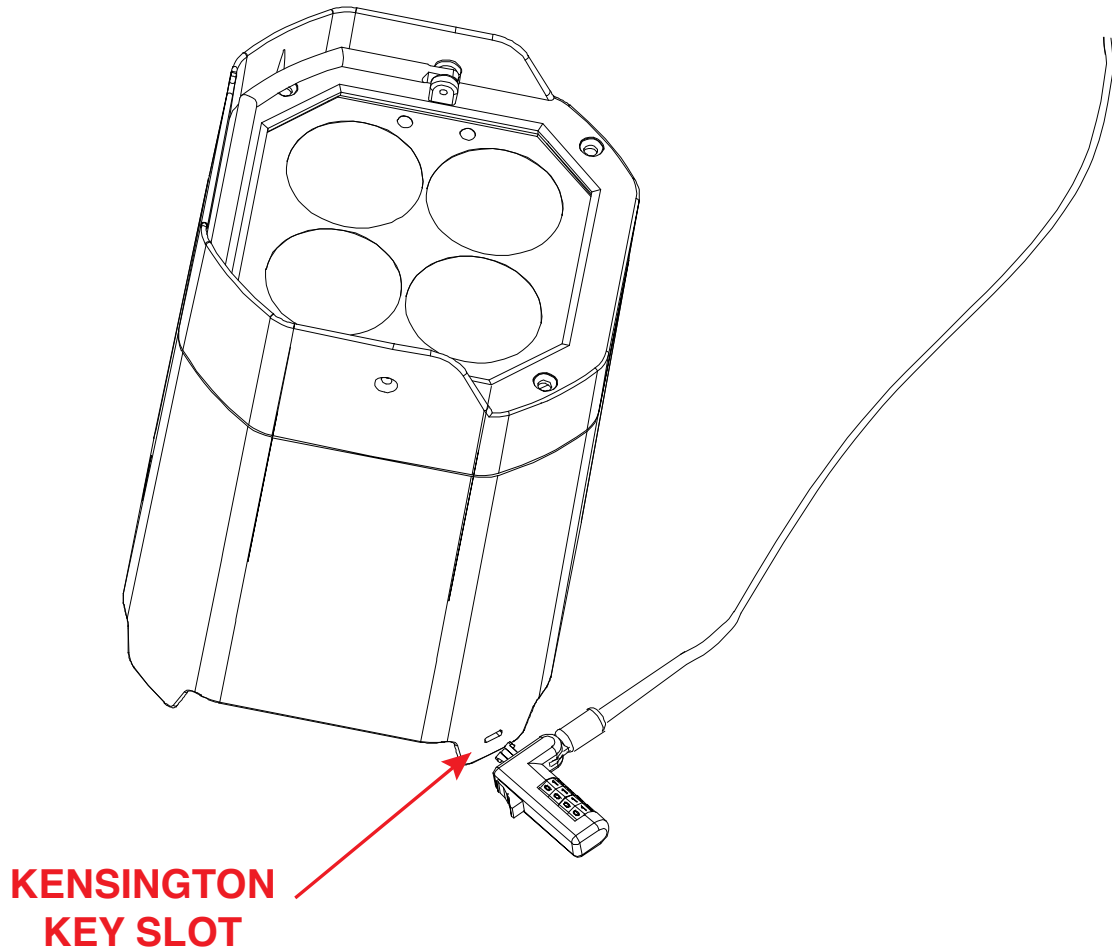

CONTROL PANEL

This fixture includes an easy to navigate control panel display, from which all necessary settings and adjustments can be made. Press the **MODE** button to scroll through the main menu options, then press **SET UP** to select the currently displayed option. Then use the **UP** and **DOWN** buttons to scroll through the sub-menu options until reaching the desired setting. Press the **MODE** button at any time to return to the main menu without making any adjustments.

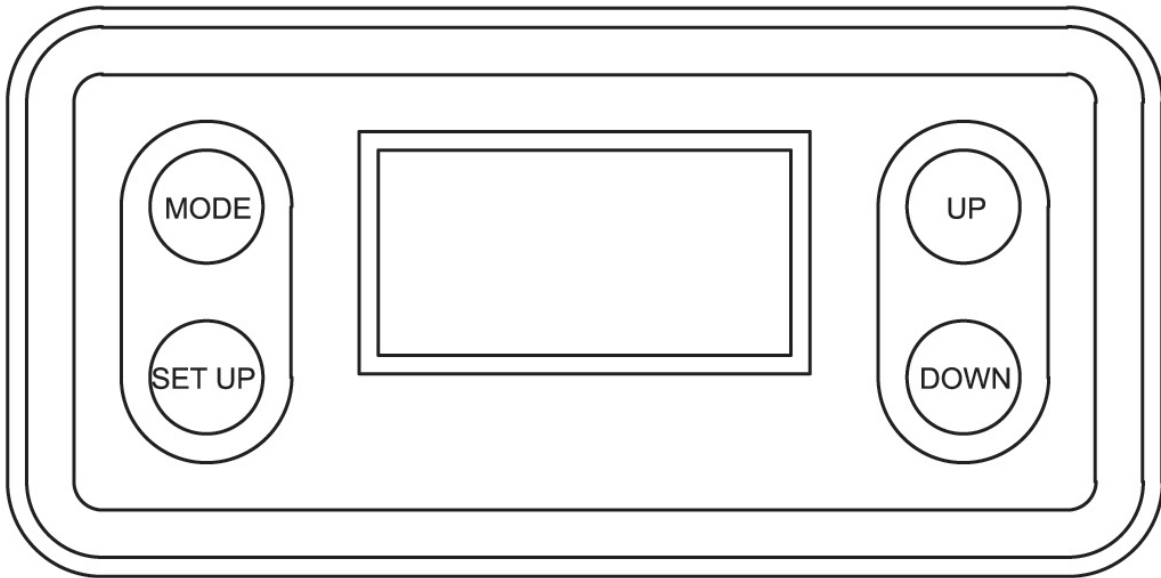

SYSTEM MENU

DMX SETTINGS	DMX Address	001 - 512	
	DMX Channel Mode	4-Ch	
		6-Ch	
		7-Ch	
		8-Ch	
		9A-Ch	
		9B-Ch	
		10-Ch	
		11-Ch	
		12-Ch	
		15-Ch	
	18-Ch		
	No DMX Status	Hold Last	Holds last DMX values received before signal loss
		Blackout	Takes all channels to DMX value of 0 when signal is lost
Manual Settings		All channels go to last manual settings when signal is lost	

CONTINUED ON NEXT PAGE

SYSTEM MENU

PERSONALITY	Primary	On / Off		
	Secondary	On / Off		
	Dim Modes	Standard		
		Stage		
		TV		
		Architectural		
		Theatre		
		Stage 2		
		Dim Delay	0 - 99	
	Wireless Settings	Set Wireless Channel	00 - 15	
		Enable Wireless	Yes / No	
		Disable Wireless	Yes / No	
		Wireless On With Power	Yes / No	Set whether wireless automatically turns on when unit is powered on
	Display	Screen Saver Delay	Off, 1-10s	
		Touch Screen Lock	Off	
			30 s	
			1 min	
	Rotate Display 180	Yes / No		
	Language	Passcode = 050	English	
			Spanish	
	IR Button Colors	Button 0	Red 000 - 255	
			Green 000 - 255	
			Blue 000 - 255	
			Amber 000 - 255	
		
		Button 15	Red 000 - 255	
			Green 000 - 255	
			Blue 000 - 255	
Amber 000 - 255				

CONTINUED ON NEXT PAGE

SYSTEM MENU

PERSONALITY (continued)	Alarm (Passcode = 011)	On / Off		Set whether alarm will sound when unit is moved, alarm will sound and unit strobes red for selected alarm time
		Alarm Time	10s / 20s / 30s / 40s / 60s	
	Service (Passcode = 011)	Factory Restore	Yes / No	
MANUAL CONTROL	Red	000 - 255		
	Green	000 - 255		
	Blue	000 - 255		
	Amber	000 - 255		
	Color Macros	000 - 255		See Color Macros section for details
	Strobe	000 - 255		
	Master Dimmer	000 - 255		
INFORMATION	LED Temperature	xxx F / xxx C		
	Software Version	x.xx		
BATTERY	Charging Time	xx Hours		Time to full charge
	Current Life	xxx%		Remaining life
	Operation Mode	Standard 6		Approx 6 hrs
		Saver 10		Approx 10 hrs
Saver 14		Approx 40 hrs (when operating on a single LED)		

DMX TRAITS

4-Channel Mode

CHANNEL	DMX VALUES	DESCRIPTION
1	000 - 255	Red , 0-100%
2	000 - 255	Green , 0-100%
3	000 - 255	Blue , 0-100%
4	000 - 255	Amber , 0-100%

6-Channel Mode

CHANNEL	DMX VALUES	DESCRIPTION
1	000 - 255	Red , 0-100%
2	000 - 255	Green , 0-100%
3	000 - 255	Blue , 0-100%
4	000 - 255	Amber , 0-100%
5		Strobe
	000 - 031	LEDs Off
	032 - 063	LEDs On
	064 - 095	Strobe effect, slow to fast
	096 - 127	LEDs On
	128 - 159	Pulse effect in sequence
	160 - 191	LEDs On
	192 - 223	Random strobe effect, slow to fast
224 - 255	LEDs On	
6	000 - 255	Dimmer Intensity , 0-100%

DMX TRAITS

7-Channel Mode

CHANNEL	DMX VALUES	DESCRIPTION
1	000 - 255	Red , 0-100%
2	000 - 255	Green , 0-100%
3	000 - 255	Blue , 0-100%
4	000 - 255	Amber , 0-100%
5		Strobe
	000 - 031	LEDs Off
	032 - 063	LEDs On
	064 - 095	Strobe effect, slow to fast
	096 - 127	LEDs On
	128 - 159	Pulse, effect in sequence
	160 - 191	LEDs On
	192 - 223	Random strobe effect, slow to fast
	224 - 255	LEDs On
6	000 - 255	Dimmer Intensity , 0-100%
7		Dim Mode
	000 - 020	Standard
	021 - 040	Stage
	041 - 060	TV
	061 - 080	Architectural
	081 - 100	Theatre
	101 - 120	Stage 2
	121 - 140	Dim Speed, fast to slow (0.1s - 10.0s)
	141 - 255	Default

DMX TRAITS

8-Channel Mode

CHANNEL	DMX VALUES	DESCRIPTION
1	000 - 255	Red , 0-100%
2	000 - 255	Red Fine
3	000 - 255	Green , 0-100%
4	000 - 255	Green Fine
5	000 - 255	Blue , 0-100%
6	000 - 255	Blue Fine
7	000 - 255	Amber , 0-100%
8	000 - 255	Amber Fine

9A-Channel Mode

CHANNEL	DMX VALUES	DESCRIPTION
1	000 - 255	Red , 0-100%
2	000 - 255	Green , 0-100%
3	000 - 255	Blue , 0-100%
4	000 - 255	Amber , 0-100%
5		Strobe
	000 - 031	LEDs Off
	032 - 063	LEDs On
	064 - 095	Strobe effect, slow to fast
	096 - 127	LEDs On
	128 - 159	Pulse, effect in sequence
	160 - 191	LEDs On
	192 - 223	Random strobe effect, slow to fast
	224 - 255	LEDs On
6	000 - 255	Dimmer Intensity , 0-100%
7		Auto Programs
	000 - 010	Off
	011 - 026	Auto Program 1
	027 - 043	Auto Program 2
	044 - 060	Auto Program 3
	061 - 076	Auto Program 4

CONTINUED ON NEXT PAGE

DMX TRAITS

9A-Channel Mode (cont'd)

CHANNEL	DMX VALUES	DESCRIPTION
7		Auto Programs (cont'd)
	077 - 093	Auto Program 5
	094 - 110	Auto Program 6
	111 - 126	Auto Program 7
	127 - 143	Auto Program 8
	144 - 160	Auto Program 9
	161 - 176	Auto Program 10
	177 - 193	Auto Program 11
	194 - 210	Auto Program 12
	211 - 226	Auto Program 13
	227 - 255	No Function
8	000 - 255	Auto Program Speed , slow to fast
9	000 - 255	Auto Program Fade , least to most

9B-Channel Mode

CHANNEL	DMX VALUES	DESCRIPTION
1	000 - 255	Red , 0-100%
2	000 - 255	Green , 0-100%
3	000 - 255	Blue , 0-100%
4	000 - 255	Amber , 0-100%
5	000 - 255	Color Macros , see Color Macros section
6	000 - 255	Color Temperature , 2400K-9900K, see Color Temperature section
7		Strobe
	000 - 031	LEDs Off
	032 - 063	LEDs On
	064 - 095	Strobe effect, slow to fast
	096 - 127	LEDs On
	128 - 159	Pulse, effect in sequences
	160 - 191	LEDs On
	192 - 223	Random strobe effect, slow to fast
	224 - 255	LEDs On
8	000 - 255	Dimmer Intensity , 0-100%
9	000 - 255	Dimmer Fine

DMX TRAITS

10-Channel Mode

CHANNEL	DMX VALUES	DESCRIPTION
1	000 - 255	Red , 0-100%
2	000 - 255	Green , 0-100%
3	000 - 255	Blue , 0-100%
4	000 - 255	Amber , 0-100%
5	000 - 255	Color Temperature , 2400K-9900K, see Color Temperature section
6		Strobe
	000 - 031	LEDs Off
	032 - 063	LEDs On
	064 - 095	Strobe effect, slow to fast
	096 - 127	LEDs On
	128 - 159	Pulse, effect in sequences
	160 - 191	LEDs On
	192 - 223	Random strobe effect, slow to fast
	224 - 255	LEDs On
7	000 - 255	Dimmer Intensity , 0-100%
8	000 - 255	Dimmer Fine
9		Dim Curves
	000 - 020	Linear
	021 - 040	Square
	041 - 060	Inv. Squa
	061 - 080	S. Curve
	081 - 255	No Function
10		Refresh Rates
	000 - 015	Default
	016 - 030	900 Hz
	031 - 045	1000 Hz
	046 - 060	1100 Hz
	061 - 075	1200 Hz
	076 - 090	1300 Hz
	091 - 105	1400 Hz
	106 - 120	1500 Hz
	121 - 135	2500 Hz
	136 - 150	4000 Hz
	151 - 165	5000 Hz

CONTINUED ON NEXT PAGE

DMX TRAITS

10-Channel Mode (cont'd)

CHANNEL	DMX VALUES	DESCRIPTION
10		Refresh Rates (cont'd)
	166 - 180	10,000 Hz
	181 - 195	15,000 Hz
	196 - 210	20,000 Hz
	211 - 225	25,000 Hz
	226 - 255	No Function

11-Channel Mode

CHANNEL	DMX VALUES	DESCRIPTION
1	000 - 255	Red , 0-100%
2	000 - 255	Green , 0-100%
3	000 - 255	Blue , 0-100%
4	000 - 255	Amber , 0-100%
5	000 - 255	Color Macros , see Colors Macros section
6	000 - 255	Color Temperature , 2400K-9900K, see Color Temperature section
7		Strobe
	000 - 031	LEDs Off
	032 - 063	LEDs On
	064 - 095	Strobe effect, slow to fast
	096 - 127	LEDs On
	128 - 159	Pulse, effect in sequences
	160 - 191	LEDs On
	192 - 223	Random strobe effect, slow to fast
224 - 255	LEDs On	
8	000 - 255	Dimmer Intensity , 0-100%
9	000 - 255	Dimmer Fine
10		Dim Curves
	000 - 020	Linear
	021 - 040	Square
	041 - 060	Inv. Square
	061 - 080	S. Curve
	081 - 255	No Function

CONTINUED ON NEXT PAGE

DMX TRAITS

11-Channel Mode (cont'd)

CHANNEL	DMX VALUES	DESCRIPTION
11		<i>Refresh Rate</i>
	000 - 015	Default
	016 - 030	900 Hz
	031 - 045	1000 Hz
	046 - 060	1100 Hz
	061 - 075	1200 Hz
	076 - 090	1300 Hz
	091 - 105	1400 Hz
	106 - 120	1500 Hz
	121 - 135	2500 Hz
	136 - 150	4000 Hz
	151 - 165	5000 Hz
	166 - 180	10,000 Hz
	181 - 195	15,000 Hz
	196 - 210	20,000 Hz
	211 - 225	25,000 Hz
226 - 255	No Function	

DMX TRAITS

12-Channel Mode

CHANNEL	DMX VALUES	DESCRIPTION
1	000 - 255	Red , 0-100%
2	000 - 255	Green , 0-100%
3	000 - 255	Blue , 0-100%
4	000 - 255	Amber , 0-100%
5	000 - 255	Color Macros , see Colors Macros section
6	000 - 255	Color Temperature , 2400K-9900K, see Color Temperature section
7		Strobe
	000 - 031	LEDs Off
	032 - 063	LEDs On
	064 - 095	Strobe effect, slow to fast
	096 - 127	LEDs On
	128 - 159	Pulse, effect in sequences
	160 - 191	LEDs On
	192 - 223	Random strobe effect, slow to fast
224 - 255	LEDs On	
8	000 - 255	Dimmer Intensity , 0-100%
9	000 - 255	Dimmer Fine
10		Dim Mode
	000 - 020	Standard
	021 - 040	Stage
	041 - 060	TV
	061 - 080	Architectural
	081 - 100	Theatre
	101 - 120	Stage 2
	121 - 140	Dim Speed, fast to slow (0.1s - 10.0s)
141 - 255	Default	
11		Dim Curves
	000 - 020	Linear
	021 - 040	Square
	041 - 060	Inv. Squa
	061 - 080	S. Curve
081 - 255	No Function	

CONTINUED ON NEXT PAGE

DMX TRAITS

12-Channel Mode (cont'd)

CHANNEL	DMX VALUES	DESCRIPTION
12		<i>Refresh Rate</i>
	000 - 015	Default
	016 - 030	900 Hz
	031 - 045	1000 Hz
	046 - 060	1100 Hz
	061 - 075	1200 Hz
	076 - 090	1300 Hz
	091 - 105	1400 Hz
	106 - 120	1500 Hz
	121 - 135	2500 Hz
	136 - 150	4000 Hz
	151 - 165	5000 Hz
	166 - 180	10,000 Hz
	181 - 195	15,000 Hz
	196 - 210	20,000 Hz
	211 - 225	25,000 Hz
226 - 255	No Function	

DMX TRAITS

15-Channel Mode

CHANNEL	DMX VALUES	DESCRIPTION
1	000 - 255	Red , 0-100%
2	000 - 255	Green , 0-100%
3	000 - 255	Blue , 0-100%
4	000 - 255	Amber , 0-100%
5	000 - 255	Color Macros , see Colors Macros section
6	000 - 255	Color Temperature , 2400K-9900K, see Color Temperature section
7		Strobe
	000 - 031	LEDs Off
	032 - 063	LEDs On
	064 - 095	Strobe effect, slow to fast
	096 - 127	LEDs On
	128 - 159	Pulse, effect in sequences
	160 - 191	LEDs On
	192 - 223	Random strobe effect, slow to fast
	224 - 255	LEDs On
8	000 - 255	Dimmer Intensity , 0-100%
9	000 - 255	Dimmer Fine
10		Auto Programs
	000 - 010	Off
	011 - 026	Auto Program 1
	027 - 043	Auto Program 2
	044 - 060	Auto Program 3
	061 - 076	Auto Program 4
	077 - 093	Auto Program 5
	094 - 110	Auto Program 6
	111 - 126	Auto Program 7
	127 - 143	Auto Program 8
	144 - 160	Auto Program 9
	161 - 176	Auto Program 10
177 - 193	Auto Program 11	

CONTINUED ON NEXT PAGE

DMX TRAITS

15-Channel Mode (cont'd)

CHANNEL	DMX VALUES	DESCRIPTION
10		Auto Programs (cont'd)
	194 - 210	Auto Program 12
	211 - 226	Auto Program 13
	227 - 255	No Function
11	000 - 255	Auto Programs Speed , slow to fast
12	000 - 255	Auto Programs Fade , least to most
13		Dim Mode
	000 - 020	Standard
	021 - 040	Stage
	041 - 060	TV
	061 - 080	Architectural
	081 - 100	Theatre
	101 - 120	Stage 2
	121 - 140	Dim Speed, fast to slow (0.1s - 10.0s)
141 - 255	Default	
14		Dim Curves
	000 - 020	Linear
	021 - 040	Square
	041 - 060	Inv. Squa
	061 - 080	S. Curve
	081 - 255	No Function
15		Refresh Rate
	000 - 015	Default
	016 - 030	900 Hz
	031 - 045	1000 Hz
	046 - 060	1100 Hz
	061 - 075	1200 Hz
	076 - 090	1300 Hz
	091 - 105	1400 Hz
	106 - 120	1500 Hz
	121 - 135	2500 Hz

CONTINUED ON NEXT PAGE

DMX TRAITS

15-Channel Mode (cont'd)

CHANNEL	DMX VALUES	DESCRIPTION
15		Refresh Rate (cont'd)
	136 - 150	4000 Hz
	151 - 165	5000 Hz
	166 - 180	10,000 Hz
	181 - 195	15,000 Hz
	196 - 210	20,000 Hz
	211 - 225	25,000 Hz
	226 - 255	No Function

18-Channel Mode

CHANNEL	DMX VALUES	DESCRIPTION
1	000 - 255	Red , 0-100%
2	000 - 255	Red Fine
3	000 - 255	Green , 0-100%
4	000 - 255	Green Fine
5	000 - 255	Blue , 0-100%
6	000 - 255	Blue Fine
7	000 - 255	Amber , 0-100%
8	000 - 255	Amber Fine
9	000 - 255	Color Macros , see Color Macros section
10	000 - 255	Color Temperature , 2400K-9900K, see Color Temperature section
11		Strobe
	000 - 031	LEDs Off
	032 - 063	LEDs On
	064 - 095	Strobe effect, slow to fast
	096 - 127	LEDs On
	128 - 159	Pulse, effect in sequence
	160 - 191	LEDs On
	192 - 223	Random strobe effect, slow to fast
224 - 255	LEDs On	
12	000 - 255	Dimmer Intensity , 0-100%

CONTINUED ON NEXT PAGE

DMX TRAITS

18-Channel Mode (cont'd)

CHANNEL	DMX VALUES	DESCRIPTION
13		Auto Programs
	000 - 010	Off
	011 - 026	Auto Program 1
	027 - 043	Auto Program 2
	044 - 060	Auto Program 3
	061 - 076	Auto Program 4
	077 - 093	Auto Program 5
	094 - 110	Auto Program 6
	111 - 126	Auto Program 7
	127 - 143	Auto Program 8
	144 - 160	Auto Program 9
	161 - 176	Auto Program 10
	177 - 193	Auto Program 11
	194 - 210	Auto Program 12
	211 - 226	Auto Program 13
227 - 255	No Function	
14	000 - 255	Auto Programs Speed , slow to fast
15	000 - 255	Auto Programs Fade , least to most
16		Dim Mode
	000 - 020	Standard
	021 - 040	Stage
	041 - 060	TV
	061 - 080	Architectural
	081 - 100	Theatre
	101 - 120	Stage 2
	121 - 140	Dim Speed, fast to slow (0.1s - 10.0s)
	141 - 255	Default

CONTINUED ON NEXT PAGE

DMX TRAITS

18-Channel Mode (cont'd)

CHANNEL	DMX VALUES	DESCRIPTION
17		<i>Dim Curves</i>
	000 - 020	Linear
	021 - 040	Square
	041 - 060	Inv. Squa
	061 - 080	S. Curve
	081 - 255	No Function
18		<i>Refresh Rate</i>
	000 - 015	Default
	016 - 030	900 Hz
	031 - 045	1000 Hz
	046 - 060	1100 Hz
	061 - 075	1200 Hz
	076 - 090	1300 Hz
	091 - 105	1400 Hz
	106 - 120	1500 Hz
	121 - 135	2500 Hz
	136 - 150	4000 Hz
	151 - 165	5000 Hz
	166 - 180	10,000 Hz
	181 - 195	15,000 Hz
	196 - 210	20,000 Hz
	211 - 225	25,000 Hz
226 - 255	No Function	

COLOR MACROS

Macro No.	DMX Value	Red	Green	Blue	W/A
OFF	000	0	0	0	0
1	001-004	80	255	234	80
2	005-008	80	255	164	80
3	009-012	77	255	112	77
4	013-016	117	255	83	83
5	017-020	160	255	77	77
6	021-024	223	255	83	83
7	025-028	255	243	77	77
8	029-032	255	200	74	74
9	033-036	255	166	77	77
10	037-040	255	125	74	74
11	041-044	255	97	77	74
12	045-048	255	71	77	71
13	049-052	255	83	134	83
14	053-056	255	93	182	93
15	057-060	255	96	236	96
16	061-064	238	93	255	93
17	065-068	196	87	255	87
18	069-072	150	90	255	90
19	073-076	100	77	255	77
20	077-080	77	100	255	77
21	081-084	67	148	255	67
22	085-088	77	195	255	77
23	089-092	77	234	255	77
24	093-096	158	255	144	144
25	097-100	255	251	153	153
26	101-104	255	175	147	147
27	105-108	255	138	186	138
28	109-112	255	147	251	147
29	113-116	151	138	255	138
30	117-120	99	0	255	100
31	121-124	138	169	255	138
32	125-128	255	255	255	255

Macro No.	DMX Value	Red	Green	Blue	W/A
33	129-132	255	206	143	0
34	133-136	254	177	153	0
35	137-140	254	192	138	0
36	141-144	254	165	98	0
37	145-148	254	121	0	0
38	149-152	176	17	0	0
39	153-156	96	0	11	0
40	157-160	234	139	171	0
41	161-164	224	5	97	0
42	165-168	175	77	173	0
43	169-172	119	130	199	0
44	173-176	147	164	212	0
45	177-180	88	2	163	0
46	181-184	0	38	86	0
47	185-188	0	142	208	0
48	189-192	52	148	209	0
49	193-196	1	134	201	0
50	197-200	0	145	212	0
51	201-204	0	121	192	0
52	205-208	0	129	184	0
53	209-212	0	83	115	0
54	213-216	0	97	166	0
55	217-220	1	100	167	0
56	221-224	0	40	86	0
57	225-228	209	219	182	0
58	229-232	42	165	85	0
59	233-236	0	46	35	0
60	237-240	8	107	222	0
61	241-244	255	0	0	0
62	245-248	0	255	0	0
63	249-252	0	0	255	0
64	253-255	0	0	0	255

IR DEFAULT RGBA VALUES

BUTTON	RED	GREEN	BLUE	AMBER
0	255	255	255	255
1	255	0	0	0
2	0	255	0	0
3	0	0	255	0
4	255	46	0	0
5	0	255	28	0
6	17	0	75	0
7	255	83	0	63
8	0	255	52	0
9	32	0	75	22
10	0	0	0	255
11	0	114	160	0
12	100	0	97	0
13	255	255	0	255
14	0	75	136	0
15	146	0	80	0

COLOR TEMPERATURE

Color Temp	DMX Value
No Function	000 - 015
2400K	016 - 031
2600K	032 - 047
2900K	048 - 063
3200K	064 - 079
3600K	080 - 095
3900K	096 - 111
4300K	112 - 127
4500K	128 - 143
4900K	144 - 159
5300K	160 - 175
5900K	176 - 191
6700K	192 - 207
7500K	208 - 223
8700K	224 - 239
9900K	240 - 255

DIMMER CURVES

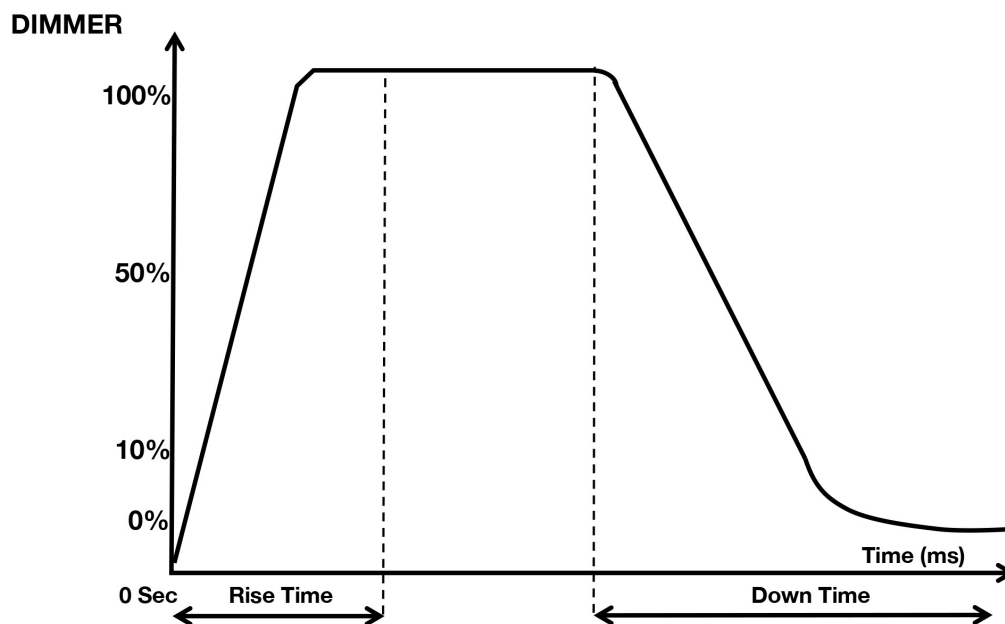

Dimming Curve Ramp Effect	0 sec Fade Time		1 sec Fade Time	
	Rise Time (ms)	Down Time (ms)	Rise Time (ms)	Down Time (ms)
Standard (default)	0	0	0	0
Stage	780	1100	1540	1660
TV	1180	1520	1860	1940
Architectural	1380	1730	2040	2120
Theatre	1580	1940	2230	2280
Stage 2	0	1100	0	1660

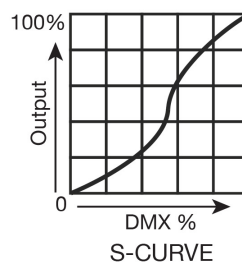
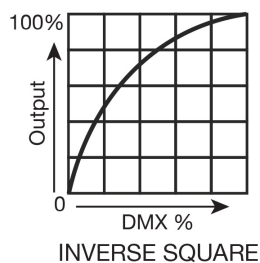
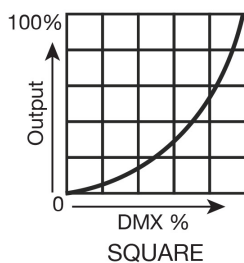
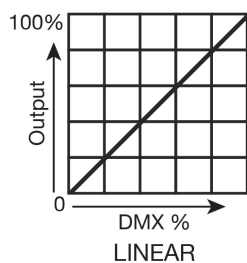

CLEANING & MAINTENANCE

WARNING! DISCONNECT UNIT FROM POWER BEFORE PERFORMING ANY CLEANING OR MAINTENANCE PROCEDURES!

ALWAYS ALLOW THE FIXTURE TO COOL FOR AT LEAST 15 MINUTES BEFORE PERFORMING ANY CLEANING OR MAINTENANCE!

CLEANING

Frequent cleaning is recommended to ensure proper function, optimized light output, and an extended life. The frequency of cleaning depends on the environment in which the fixture operates: damp, smoky, or particularly dirty environments can cause greater accumulation of dirt on the fixture's optics. Clean periodically with a soft cloth to avoid dirt/debris accumulation.

NEVER use alcohol, solvents, or ammonia-based cleaners.

MAINTENANCE

Regular inspections are recommended to ensure proper function and extended life. There are no user serviceable parts inside this fixture. Please refer all other service issues to an authorized ADJ service technician. Should you need any spare parts, please order genuine parts from an authorized ADJ dealer.

Please refer to the following points during routine inspections:

- A detailed electrical check by an approved electrical engineer every three months, to make sure the circuit contacts are in good condition and prevent overheating.
- Be sure all screws and fasteners are securely tightened at all times. Loose screws may fall out during normal operation, resulting in damage or injury as larger parts could fall.
- Check for any deformations on the housing, color lenses, rigging hardware and rigging points (ceiling, suspension, trussing). Deformations in the housing could allow for dust to enter into the fixture. Damaged rigging points or unsecured rigging could cause the fixture to fall and seriously injure a person(s).
- Electric power supply cables must not show any damage, material fatigue, or sediments.

TORQUE SETTINGS

IN ORDER TO MAINTAIN THE IP65 RATING ON THE LIGHTING FIXTURES, ALL SCREWS MUST BE TIGHTENED TO THE FOLLOWING TORQUE SPECIFICATION USING A TORQUE DRIVER.

These screws must be torqued to *11.3 lb-in (13.0 kg-cm)*.

TORQUE DRIVERS (Recommended): UTICA TS-30 (shown)

ALTERNATE DRIVERS:

- Proto J6107A
- Wiha 28887



CAUTION! DO NOT OVER TORQUE SCREWS AS THIS CAN CAUSE LEAKAGE ISSUES! TO CONFIRM THE IP65 INTEGRITY AFTER A LAMP REPLACEMENT, TEST THE FIXTURE USING THE ELATION IP TESTER. CONTACT ELATION SERVICE FOR MORE DETAILS.



CAUTION! THE USE OF PROTECTIVE GLOVES AND SAFETY GOGGLES IS STRONGLY RECOMMENDED WHILE PERFORMING THE IP PRESSURE TEST! AVOID PLACING YOUR FACE, EYES, HANDS, ETC IN CLOSE PROXIMITY TO THE FIXTURE'S LENS WHILE PERFORMING THE TEST!



IP PRESSURE TESTING PARAMETERS		
Low Pressure Limit	High Pressure Limited	Steady/Hold Time
1.65 psi (11.4 KPa)	1.70 psi (11.7 KPa)	3 sec

BATTERY LIFE

Following any software update, the battery life information setting must be reset before it will display accurate information. This can be done by following the steps below:

1. Navigate to Battery > Operation Mode in the system menu and make sure that the device is set to either Standard 6 or Saver 10.
2. Navigate to Battery > Current Life in the system menu.
3. Press and hold the UP button until the device flashes amber once. The device should now display an accurate battery life reading.

DIMENSIONAL DRAWINGS

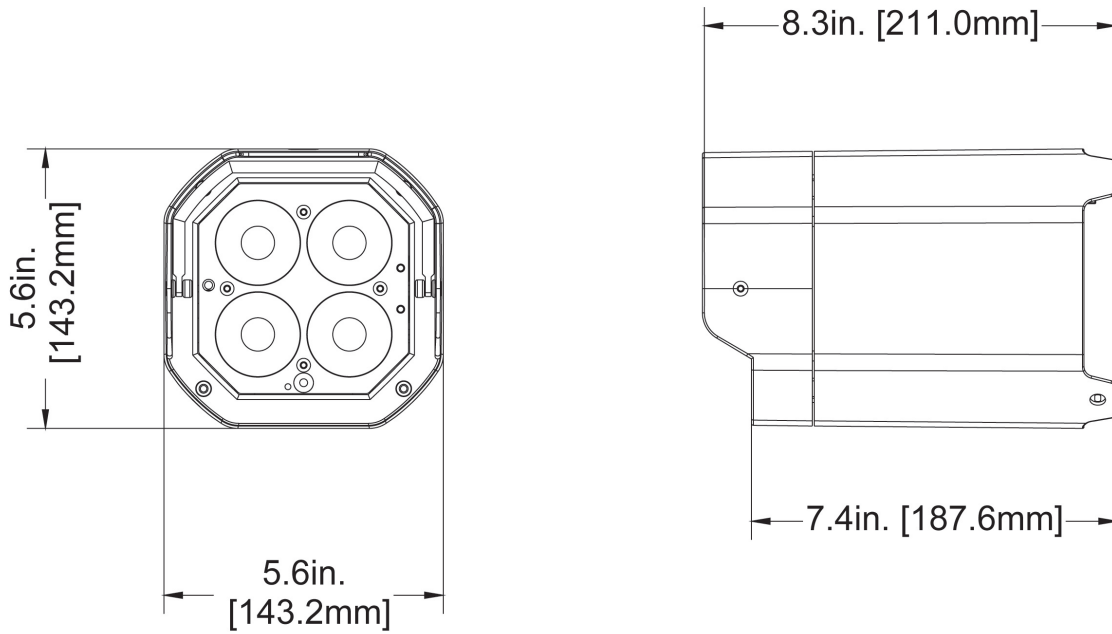

Dimensions may not be drawn to scale.

SPECIFICATIONS

Optical:

- 4 x 10-Watt RGBA LEDs (4-in-1 - Red, Green, Blue & Amber)
- Life expectancy: rated at 50,000 hrs.
- LUX: 9903 @ 2M; 2303 @ 4M
- Beam angle: 15-degree
- Color Temperature: 2400K - 9900K

Connection:

- DMX: Wireless DMX
- With Wired Digital Communication Network
- Contact Charging system. *Charging base and power supply included

Control:

- Control protocol: Wireless DMX
- 11 DMX Channel modes: 4, 6, 7, 8, 9A, 9B, 10, 11, 12, 15 or 18 channels
- Remote control: Wireless DMX, UC-IR (Included)
- 3 Operational modes: RGBA Dimmer Mode; Static Color mode; and DMX Controlled

Features:

- IP65 Outdoor Rated
- Built-in kickstand to angle fixture when sitting on the floor
- 4-touch button OLED display on rear panel
- Built-in wireless DMX: Up to 2,500 feet (760M) when used with ADJ's Battery Transceiver
- 64 built-in Color Macros
- Variable RGBA color mixing offers a smooth, seemingly unlimited color palette - Great for Wall Washing!
- LED pulse and strobe effect (0.2Hz-11Hz)
- Flicker Free Operation
- Electronic Dimming: 0 - 100% with 6 dim modes and 4 dim curves
- Run all night – No duty cycle
- Built-in alarm system with On/Off
- Battery charge indicator on each fixture
- Energy Save Mode

Battery:

- Battery Type: fixed lithium battery
- Battery Energy: 162.8WH(Watt Hours)
- Battery Weight: 0.84 kg.
- Battery Voltage: 14.8V
- Battery Capacity: 11000mAh (Typical Capacity)
- Total Lithium Ion Cells: 20 pieces
- Battery Wrap Material: PVC sleeving + highland barley paper
- Battery Charge Time: 7 Hours
- Battery Life: 40 hours (single color)

Electrical:

- Power Draw Total (All LED's @ Full On): 43W
- Voltage operation: DC17V

Dimensions / Weight:

- Dimensions (LxWxH): 5.6" x 5.6" x 8.3" / 143 x 143 x 211mm
- Weight: 6.17 lbs. / 2.8kg.

Certifications:

- ETL Approved (4002034)
- CE Approved

