



HYDRO SPOT I

User Manual

©2024 ADJ Products, LLC all rights reserved. Information, specifications, diagrams, images, and instructions herein are subject to change without notice. ADJ Products, LLC logo and identifying product names and numbers herein are trademarks of ADJ Products, LLC. Copyright protection claimed includes all forms and matters of copyrightable materials and information now allowed by statutory or judicial law or hereinafter granted. Product names used in this document may be trademarks or registered trademarks of their respective companies and are hereby acknowledged. All non-ADJ Products, LLC brands and product names are trademarks or registered trademarks of their respective companies.

ADJ Products, LLC and all affiliated companies hereby disclaim any and all liabilities for property, equipment, building, and electrical damages, injuries to any persons, and direct or indirect economic loss associated with the use or reliance of any information contained within this document, and/or as a result of the improper, unsafe, insufficient and negligent assembly, installation, rigging, and operation of this product.

ADJ PRODUCTS LLC World Headquarters

6122 S. Eastern Ave. | Los Angeles, CA 90040 USA
 Tel: 800-322-6337 | Fax: 323-582-2941 | www.adj.com | lsupport@adj.com

ADJ Supply Europe B.V.

Junostraat 2 | 6468 EW Kerkrade | Netherlands
 Tel: +31 45 546 85 00 | Fax: +31 45 546 85 99 | www.americandj.eu | service@americandj.eu

Europe Energy Saving Notice

Energy Saving Matters (EuP 2009/125/EC)

Saving electric energy is a key to help protecting the environment. Please turn off all electrical products when they are not in use. To avoid power consumption in idle mode, disconnect all electrical equipment from power when not in use. Thank you!

DOCUMENT VERSION



Due to additional product features and/or enhancements, an updated version of this document may be available online.

Please check www.adj.com for the latest revision/update of this manual before beginning installation and/or programming.

Date	Document Version	Software Version	DMX Channels	Notes
06/30/2022	1.0	1.01	17 / 20 / 22 ch.	Initial Release
07/21/2022	1.1	N/C	No change	Corrected RDM, System Menu, DMX Traits, and Specifications
08/12/2022	1.2	N/C	No change	Updated Control Panel and Specifications.
10/19/2022	1.3	N/C	No change	Updated Dimension Drawings
02/27/2024	1.4	N/C	No change	Updated Ambient Temperature
04/17/2024	1.5	N/C	No change	Updated Specifications
05/17/2024	1.6	N/C	No Change	Added Ambient Temperature
09/16/2024	1.7	N/C	No Change	Updated Gobos

TABLE OF CONTENTS

Introduction	4
Limited Warranty (USA Only)	5
Warranty Registration Features	6
Safety Precautions	7
Overview	9
Installation	10
Remote Device Management (RDM)	13
Color Wheels	14
Gobos	15
Control Panel	18
System Menu	19
DMX Set Up	22
DMX Traits	24
Dim Speeds	31
Dim Modes	32
Primary-Secondary Set Up Multi Unit Power Linking	33
Maintenance Guidelines	34
Torque Settings for Screws	35
Error Codes	37
Dimensional Drawings	38
Specifications	39

GENERAL INFORMATION

INTRODUCTION

Please read and understand the instructions in this manual carefully and thoroughly before attempting to operate this device. These instructions contain important safety and use information.

This product is intended for use by professionally trained personnel only, and is not suitable for private use.

Unpacking

Every device has been thoroughly tested and has been shipped in perfect operating condition. Carefully check the shipping carton for damage that may have occurred during shipping. If the carton is damaged, carefully inspect the device for damage, and be sure all accessories necessary to install and operate the device have arrived intact. In the event damage has been found or parts are missing, please contact our customer support team for further instructions. Please do not return this device to your dealer without first contacting customer support. Please do not discard the shipping carton in the trash. Please recycle whenever possible.

BOX CONTENTS

Omega Brackets
1.83M locking power cable

CUSTOMER SUPPORT

Contact ADJ Service for any product related service and support needs.
Also visit forums.adj.com with questions, comments or suggestions.

ADJ SERVICE USA - Monday - Friday 8:00am to 4:30pm PST
323-582-2650 | Fax: 323-832-2941 | support@adj.com

ADJ SERVICE EUROPE - Monday - Friday 08:30 to 17:00 CET
+31 45 546 85 60 | Fax: +31 45 546 85 96 | support@adj.eu

REPLACEMENT PARTS please visit parts.adj.com

IMPORTANT NOTICE!

**THERE ARE NO USER SERVICEABLE PARTS INSIDE THIS UNIT.
DO NOT ATTEMPT ANY REPAIRS YOURSELF; DOING SO WILL VOID YOUR MANUFACTURER'S WARRANTY. DAMAGES RESULTING FROM MODIFICATIONS TO THIS FIXTURE AND/OR THE DISREGARD OF SAFETY INSTRUCTIONS AND GUIDELINES IN THIS MANUAL VOID THE MANUFACTURER'S WARRANTY AND ARE NOT SUBJECT TO WARRANTY CLAIMS AND/OR REPAIRS.**

LIMITED WARRANTY (USA ONLY)

- A. ADJ Products, LLC hereby warrants, to the original purchaser, ADJ Products, LLC products to be free of manufacturing defects in material and workmanship for a prescribed period from the date of purchase (see specific warranty period on reverse). This warranty shall be valid only if the product is purchased within the United States of America, including possessions and territories. It is the owner's responsibility to establish the date and place of purchase by acceptable evidence, at the time service is sought.
- B. For warranty service, you must obtain a Return Authorization number (RA#) before sending back the product-please contact ADJ Products, LLC Service Department at 800-322-6337. Send the product only to the ADJ Products, LLC factory. All shipping charges must be pre-paid. If the requested repairs or service (including parts replacement) are within the terms of this warranty, ADJ Products, LLC will pay return shipping charges only to a designated point within the United States. If the entire instrument is sent, it must be shipped in its original package. No accessories should be shipped with the product. If any accessories are shipped with the product, ADJ Products, LLC shall have no liability whatsoever for loss of or damage to any such accessories, or for the safe return thereof.
- C. This warranty is void if the serial number has been altered or removed; if the product is modified in any manner which ADJ Products, LLC concludes, after inspection, affects the reliability of the product, if the product has been repaired or service by anyone other than ADJ Products, LLC factory unless prior written authorization was issued to purchaser by ADJ Products, LLC; if the product is damaged because not properly maintained as set forth in the instruction manual.
- D. This is not a service contract, and this warranty does not include maintenance, cleaning or periodic check up. During the period specified above, ADJ Products, LLC will replace defective parts at its expense with new or refurbished parts, and will absorb all expenses for warranty service and repair labor by reason of defects in material or workmanship. The sole responsibility of ADJ Products, LLC under this warranty shall be limited to the repair of the product, or replacement thereof, including parts, at the sole discretion of ADJ Products, LLC. All products covered by this warranty were manufactured after August 15, 2012, and bear identifying marks to that effect.
- E. ADJ Products, LLC reserves the right to make changes in design and/or improvements upon its products without any obligation to include these changes in any products theretofore manufactured.
- F. No warranty, whether expressed or implied, is given or made with respect to any accessory supplied with products described above. Except to the extent prohibited by applicable law, all implied warranties made by ADJ Products, LLC in connection with this product, including warranties of merchantability or fitness, are limited in duration to the warranty period set forth above. And no warranties, whether expressed or implied, including warranties of merchantability or fitness, shall apply to this product after said period has expired. The consumer's and/or Dealer's sole remedy shall be such repair or replacement as is expressly provided above; and under no circumstances shall ADJ Products, LLC be liable for any loss or damage, direct or consequential, arising out of the use of, or inability to use, this product.
- G. This warranty is the only written warranty applicable to ADJ Products, LLC Products and supersedes all prior warranties and written descriptions of warranty terms and conditions heretofore published.

LIMITED WARRANTY PERIODS

- **Non L.E.D. Lighting Products = 1-year (365 days) Limited Warranty** (Such as: Special Effect Lighting, Intelligent Lighting, UV lighting, Strobes, Fog Machines, Bubble Machines, Mirror Balls, Par Cans, Trussing, Lighting Stands etc. excluding LED and lamps)
- **Laser Products = 1 Year (365 Days) Limited Warranty** (excludes laser diodes which have 6 month limited warranty)
- **L.E.D. Products = 2-year (730 days) Limited Warranty** (excluding batteries which have a 180 day limited warranty)
Note: 2 Year Warranty only applies to purchases within the United States.
- **StarTec Series = 1 Year Limited Warranty** (excluding batteries which have a 180 day limited warranty)
- **ADJ DMX Controllers = 2 Year (730 Days) Limited Warranty**

WARRANTY REGISTRATION

The Hydro Spot 1 carries a 2 year limited warranty. Please fill out the enclosed warranty card to validate your purchase. All returned service items, whether under warranty or not, must be freight pre-paid and accompanied by a return authorization (R.A.) number. The R.A. number must be clearly written on the outside of the return package. A brief description of the problem as well as the R.A. number must also be written down on a piece of paper included in the shipping carton. If the unit is under warranty, you must provide a copy of your proof of purchase invoice. You may obtain an R.A. number by contacting our customer support team on our customer support number. All packages returned to the service department not displaying an R.A. number on the outside of the package will be returned to the shipper.

FEATURES

- Motorized Focus
- Motorized Zoom: 12° ~ 23°
- 2 Frost Filters (Heavy and Medium)
- 2 Prism FX: Rotating 5-facet Linear & rotating 6-facet Circular
- 0-100% smooth dimming
- Various strobe speeds
- 2 cooling fans

INCLUDED ITEMS

- Omega Bracket (x1)
- Locking Power Cable (x1)

IP RATING

An IP rated lighting fixture is commonly installed in outdoor environments and has been designed with an enclosure that effectively protects the ingress (entry) of external foreign objects such as dust and water. The Ingress Protection (IP) rating system is commonly expressed as “IP” followed by two numbers (i.e. IP65), where the numbers define the degree of protection. The first digit (Foreign Bodies Protection) indicates the extent of protection against particles entering the fixture and the second digit (Water Protection) indicates the extent of protection against water entering the fixture. **An IP65 rated lighting fixture, such as this one, has been designed and tested to protect against the ingress of dust (6) and low-pressure water jets from any direction (5). INTENDED FOR TEMPORARY OUTDOOR USE ONLY!**

SAFETY PRECAUTIONS



PROTECTION CLASS 1 - FIXTURE MUST BE PROPERLY GROUNDED.



THERE ARE NO USER SERVICEABLE PARTS INSIDE THIS UNIT. DO NOT ATTEMPT ANY REPAIRS YOURSELF, AS DOING SO WILL VOID YOUR MANUFACTURER'S WARRANTY. DAMAGES RESULTING FROM MODIFICATIONS TO THIS FIXTURE AND/OR THE DISREGARD OF SAFETY INSTRUCTIONS AND GUIDELINES IN THIS MANUAL VOID THE MANUFACTURER'S WARRANTY AND ARE NOT SUBJECT TO ANY WARRANTY CLAIMS AND/OR REPAIRS.



**NEVER LOOK DIRECTLY INTO THE LIGHT SOURCE!
RETINA INJURY RISK - MAY INDUCE BLINDNESS!
SENSITIVE PERSONS MAY SUFFER AN EPILEPTIC SHOCK!**

- **Minimum/Maximum ambient operating temperature is -4° to 113° F (-20 to 45° C)!**
- DO NOT TOUCH the fixture housing during operation. Disconnect the power and allow approximately 15 minutes for the fixture to cool down before servicing.
- DO NOT shake the fixture, and avoid brute force when installing and/or operating the fixture.
- DO NOT operate the fixture if the power cord has become frayed, crimped and/or damaged. If the power cord is damaged, replace immediately with a new one of the same power rating.
- DO NOT attempt to remove or break off the ground prong from the electrical cord. This prong is used to reduce the risk of electrical shock and fire in case of an internal short.
- DO NOT attempt to operate this unit if it has been damaged in any way.
- DO NOT spill water or other liquids into or on to your unit.
- Disconnect from main power before making any type of connection.
- DO NOT block any air ventilation slots. All fan and air inlets must remain clean and never blocked. Allow approx. 6" (15cm) between fixture and other devices or a wall for proper cooling.
- Always be sure to mount this unit in an area that will allow proper ventilation.
- DO NOT remove the cover under for any reason.
- When installing fixture in a suspended environment, always use mounting hardware that is no less than M10 x 25mm, and always install fixture with an appropriately rated safety cable.
- Never plug this unit in to a dimmer pack.
- During long periods of non-use, disconnect the unit's main power.
- Always mount this unit in safe and stable matter.
- Power-supply cords should be routed so that they are not likely to be walked on or pinched by items placed upon or against them, paying particular attention to the point where they exit from the unit.
- Cleaning - The fixture should be cleaned only as recommended by the manufacturer.
- Heat - The appliance should be situated away from heat sources such as radiators, heat registers, stoves, or other appliances (including amplifiers) that produce heat.
- The fixture should be serviced by qualified service personnel when:
 - A. The power-supply cord or the plug have been damaged.
 - B. Objects have fallen onto, or liquid has been spilled into, the fixture.
 - C. The fixture does not appear to operate normally or exhibits a marked change in performance.
 - D. The fixture has fallen and/or has been subjected to extreme handling.

SAFETY PRECAUTIONS



**HIGH
INTENSITY
ULTRAVIOLET
LIGHT**

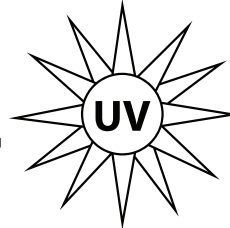

**AVOID DIRECT EYE & SKIN EXPOSURE.
WEAR PROPER EYE & SKIN PROTECTION.
SEE MANUAL FOR SAFETY INSTRUCTIONS.**

RISK GROUP 3 - RISK OF EXPOSURE TO ULTRAVIOLET (UV) RADIATION!

FIXTURE EMITS HIGH INTENSITY ULTRAVIOLET (UV) LIGHT FROM THE UV LED.

WEAR PROPER EYE AND SKIN PROTECTION.

AVOID PROLONGED PERIODS OF EXPOSURE TO THE UV LED.

AVOID WEARING WHITE COLOR CLOTHING AND/OR USING (UV) PAINTS ON SKIN.

AVOID DIRECT EYE AND/OR SKIN EXPOSURE AT DISTANCES SHORTER THAN 11 feet (3.3m).

DO NOT OPERATE FIXTURE WITH DAMAGED OR MISSING EXTERNAL COVER.

DO NOT LOOK DIRECTLY INTO THE (UV) LIGHT AND/OR VIEW (UV) LIGHT DIRECTLY WITH OPTICAL INSTRUMENTS THAT MAY CONCENTRATE THE LIGHT/RADIATION OUTPUT.

INDIVIDUALS SUFFERING FROM A RANGE OF EYE CONDITIONS, SUNLIGHT EXPOSURE DISORDERS, OR INDIVIDUALS USING PHOTSENSITIVE MEDICATION MAY EXPERIENCE DISCOMFORT IF EXPOSED TO THE ULTRAVIOLET (UV) LIGHT EMITTED FROM THIS FIXTURE.

OVERVIEW

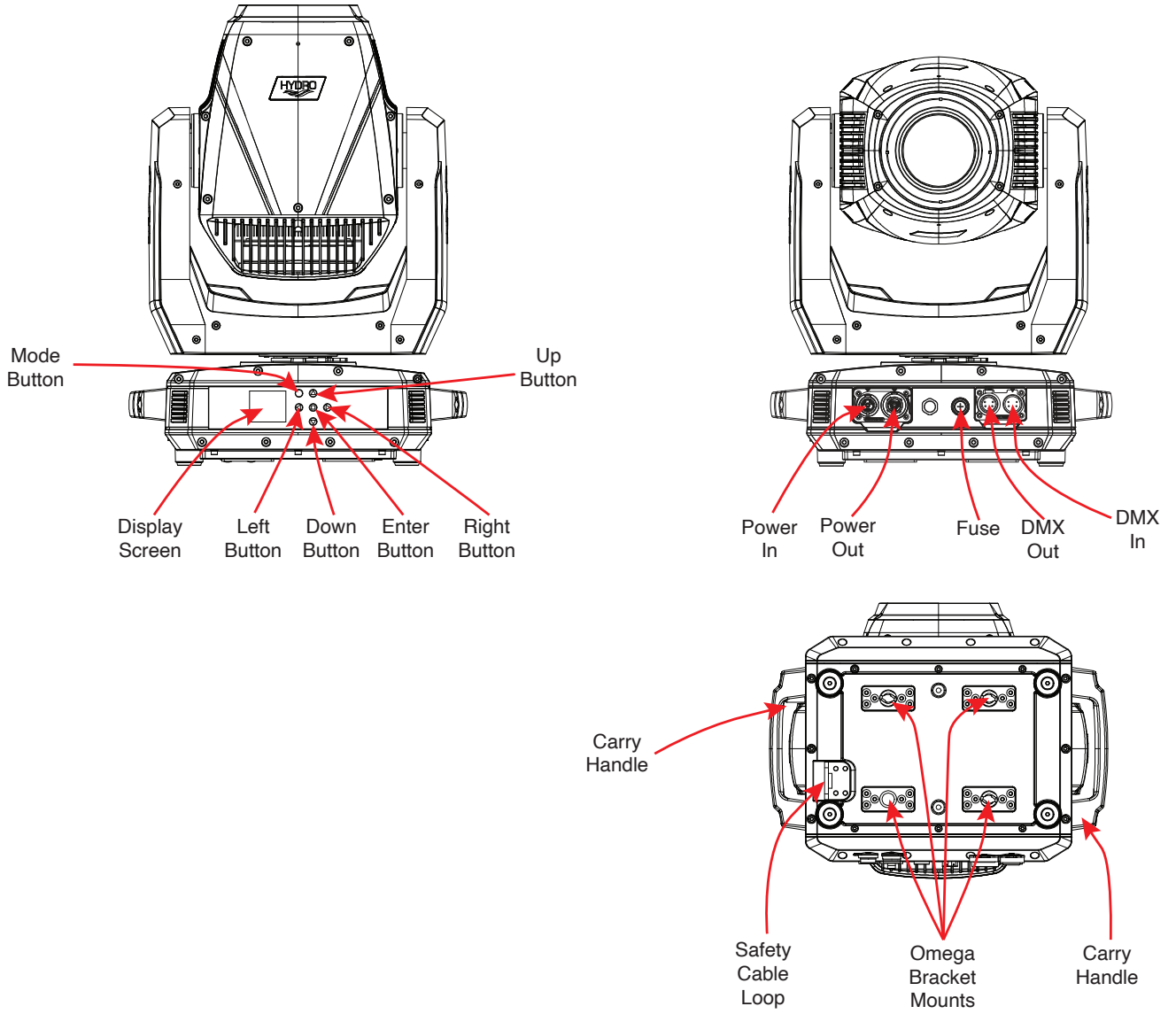

INSTALLATION



DO NOT INSTALL THE FIXTURE IF YOU ARE NOT QUALIFIED TO DO SO!

Fixture **MUST** be installed following all local, national, and country commercial electrical and construction codes and regulations.

When installing the unit, the trussing or area of installation must be able to support at least 10 times the weight of the unit and any attached accessories without any deformation. The unit must be secured with a secondary safety attachment, e.g. an appropriately-rated safety cable.

Before rigging/mounting a fixture to any metal truss/structure or placing the fixture(s) on any surface, a professional equipment installer **MUST** be consulted to determine if the metal truss/structure or surface is properly certified to safely hold the combined weight of the fixture(s), clamps, cables, and accessories.

Maximum ambient operating temperature is **113°F (45°C)**.

Fixture(s) should be installed away from walking paths, seating areas, or areas where unauthorized personnel might reach the fixture by hand.

NEVER stand directly below the fixture(s) when rigging, removing, or servicing.

Overhead fixture installation must always be secured with a secondary safety attachment, such as an appropriately rated safety cable that can hold at least 10 times the weight of the fixture.

Overhead mounting requires extensive experience, including calculating working load limits, knowledge of installation material being used, and periodic safety inspection of all installation material as well as the unit itself. If you lack these qualifications, do not attempt the installation yourself.

The installation should be checked by a skilled person once a year.

INSTALLATION

CLAMP MOUNTING

This fixture features mounting points on the underside for the attachment of two Omega brackets. Additionally, the unit also features a safety cable loop on the underside, near one of the carry handles (see the illustration below). When mounting the fixture to a truss or any other suspended or overhead installation, be sure to secure appropriately rated mounting clamps (not included) to each Omega bracket. **Please note that two Omega brackets and two mounting clamps are needed to safely support the fixture in a suspended installation.** Attach a separate **SAFETY CABLE** of the appropriate weight rating to the provided safety cable loop. **NEVER** use carry handles as an attachment points for the safety cable.

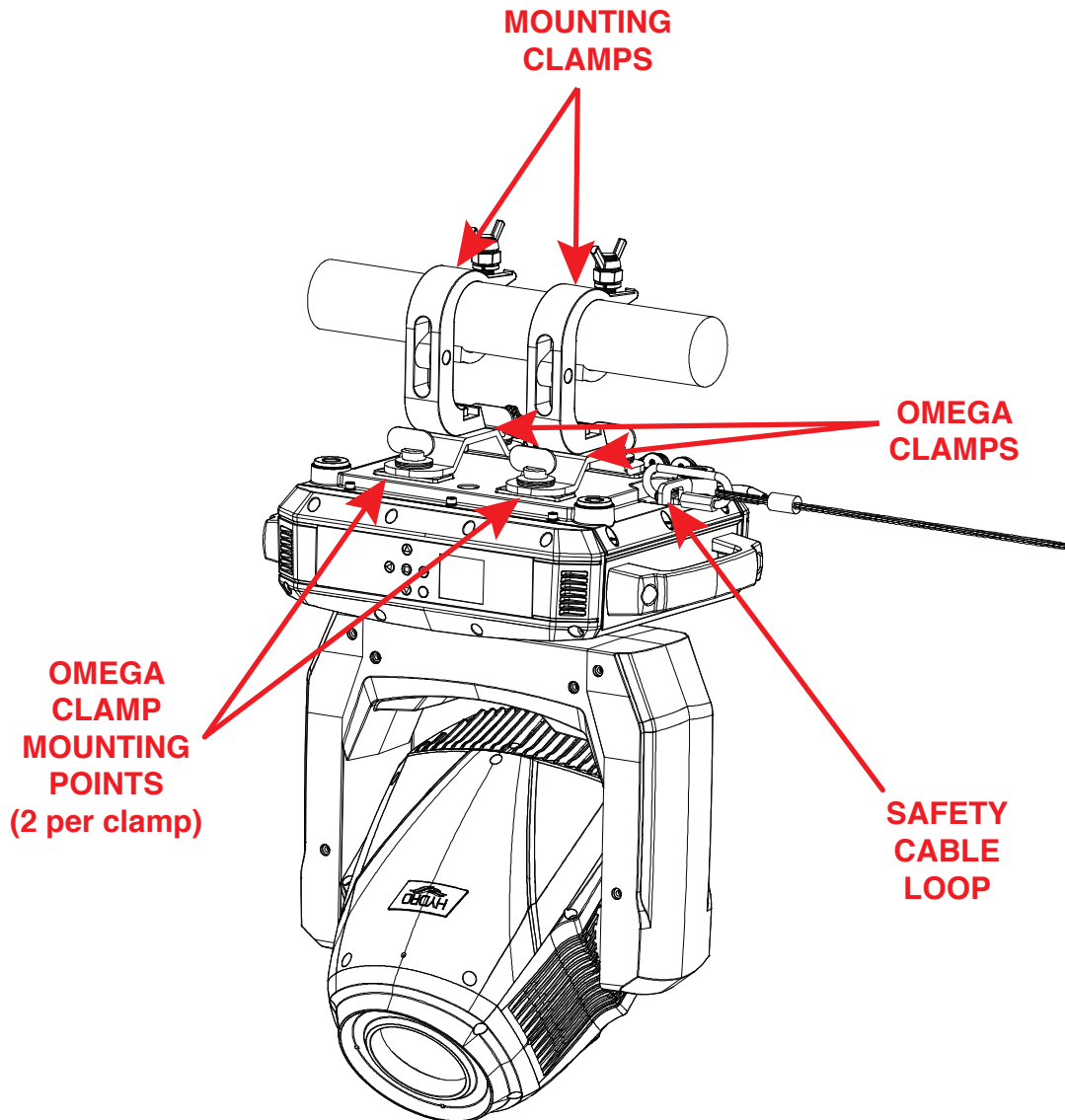

SAFETY CABLE:

ALWAYS ATTACH A SAFETY CABLE WHENEVER INSTALLING THIS FIXTURE IN A SUSPENDED ENVIRONMENT TO ENSURE THAT THE FIXTURE WILL NOT FALL IF THE CLAMP FAILS.



INSTALLATION

POTENTIAL INTERNAL FIXTURE DAMAGE FROM EXTERNAL SOURCES OF LIGHT BEAMS

External sources of light beams from direct sunlight, lighting and moving head fixtures, and lasers, which are focused directly towards the exterior housing and/or penetrate the front lens opening of ADJ lighting fixtures, can cause severe internal damage including burning of optics, dichroic color filters, glass and metal gobos, prisms, animation wheels, frost filters, iris, shutters, motors, belts, wiring, discharge lamps, and LEDs.

This issue is not specific only to ADJ lighting fixtures, but rather it is a common issue with lighting fixtures from all manufacturers. Although there is no true way to fully prevent this issue from happening, the guidelines below can reduce the risk of potential damage. Contact ADJ Service for more details.

DO NOT EXPOSE THE FIXTURE AND/OR FRONT LENS OPENING TO LIGHT BEAMS FROM DIRECT SUNLIGHT, OTHER LIGHTING OR MOVING HEAD FIXTURES, AND LASERS DURING UNPACKING, INSTALLATION, USE, AND EXTENDED IDLE TIMES OUTDOORS. DO NOT FOCUS A LIGHT BEAM FROM ONE LIGHTING FIXTURE DIRECTLY TOWARDS ANOTHER.

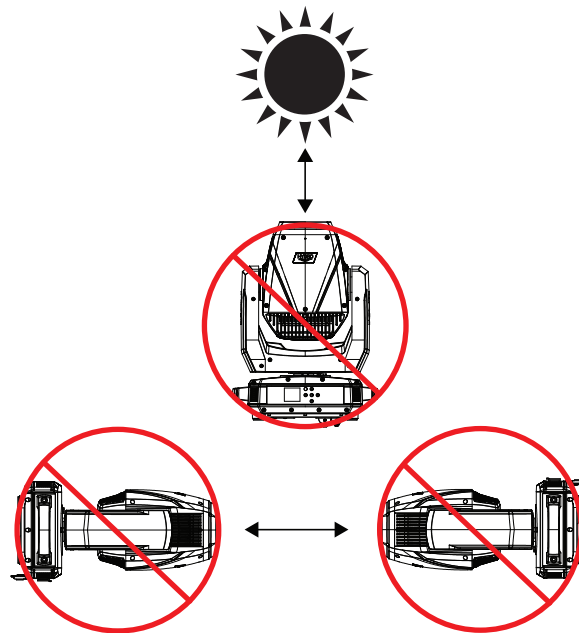

SUN PROTECTION MODE/ HIBERNATION MODE:

This state can be set via DMX, or the device will go into this state after 3 minutes without a DMX signal. This function can be switched on or off in the DMX traits (see the **DMX Traits** section for details). When the sun protection is activated, the pan-and-tilt function of the moving-head will position the lens away from direct sunlight, or other high intensity light source, to protect the internal belts, electronics etc. from burn damage.

When the unit is in the 'sun protection state', it uses its accelerometer sensors (X-Y-Z) (only present on discharge units and IP units) to position the front lens downwards, even when the unit(s) will be moved from its position. This will keep on changing the position of the head.

Please note that 'manual mode' overrides the 'sun-protection mode'. The hibernation function is an existing feature that puts the unit into a 'sleep state' to save power (this is a state where only the electronics remain on, and all other functions are turned off, functions such as motors lamps etc). This state is automatically activated when no DMX signal is present for the set time (1-99min or off).

REMOTE DEVICE MANAGEMENT (RDM)

NOTE: In order for RDM to work properly, RDM enabled equipment must be used throughout the entire system, including DMX data splitters and wireless systems.

Remote Device Management (RDM) is a protocol that sits on top of the DMX512 data standard for lighting, allowing the DMX systems of the fixtures to be modified and monitored remotely. This protocol is ideal for instances in which a unit is installed in a location that is not easily accessible.

With RDM, the DMX512 system becomes bi-directional, allowing a compatible RDM enabled controller to send out a signal to devices on the wire, as well as allowing the fixture to respond (known as a *GET* command). The controller can then use its *SET* command to modify settings that would typically have to be changed or viewed directly via the unit's display screen, including the DMX Address, DMX Channel Mode, and Temperature Sensors.

FIXTURE RDM INFORMATION:

RDM Code	Device ID	Device Model ID	Personality ID
0x1900	260000	1581	Basic (1) Standard (2) Extended (3)

Please be aware that not all RDM devices support all RDM features, and therefore it is important to check beforehand to ensure that the equipment that you are considering includes all of the features that you require.

The following parameters are accessible in RDM on this device:

[0x0015] Comms Status	[0x00E1] DMX Personality Description
[0x0020] Queued Messages	[0x0200] Sensor Definition
[0x0030] Status Message	[0x0201] Sensor Value
[0x0031] Status ID Description	[0x0400] Device Hours
[0x0032] Clear Status ID	[0x0405] Device Power Cycles
[0x0080] Device Model Description	[0x0500] Display Invert
[0x0081] Manufacturer Label	[0x0501] Display Level
[0x0082] Device Label	[0x0600] Pan Invert
[0x0090] Factory Defaults	[0x0601] Tilt Invert
[0x00C1] Boot Software Version ID	[0x1001] Reset Device
[0x00E0] DMX Personality	

COLOR WHEELS

COLOR WHEEL 1

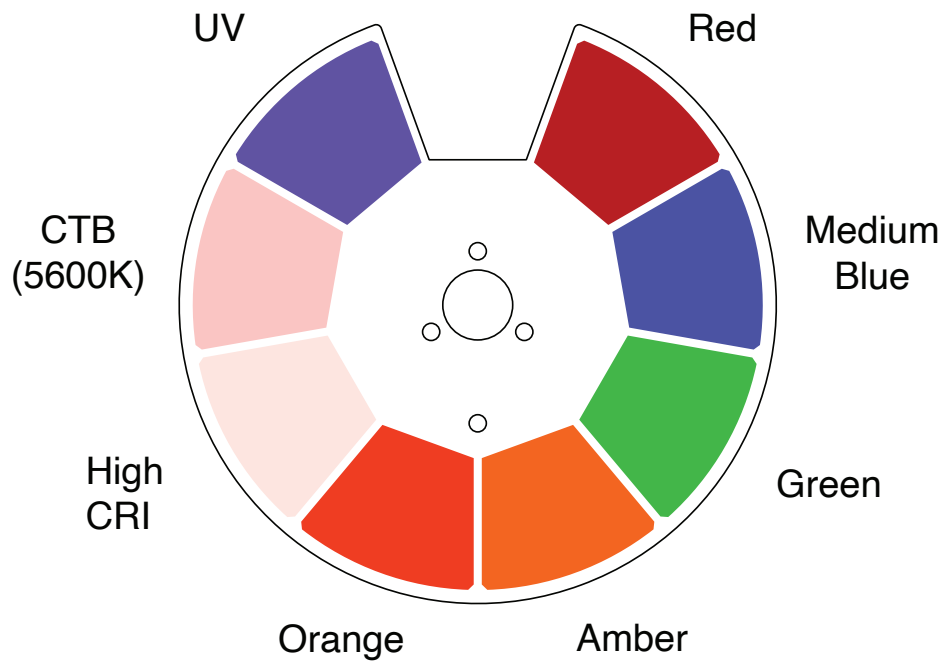

COLOR WHEEL 2

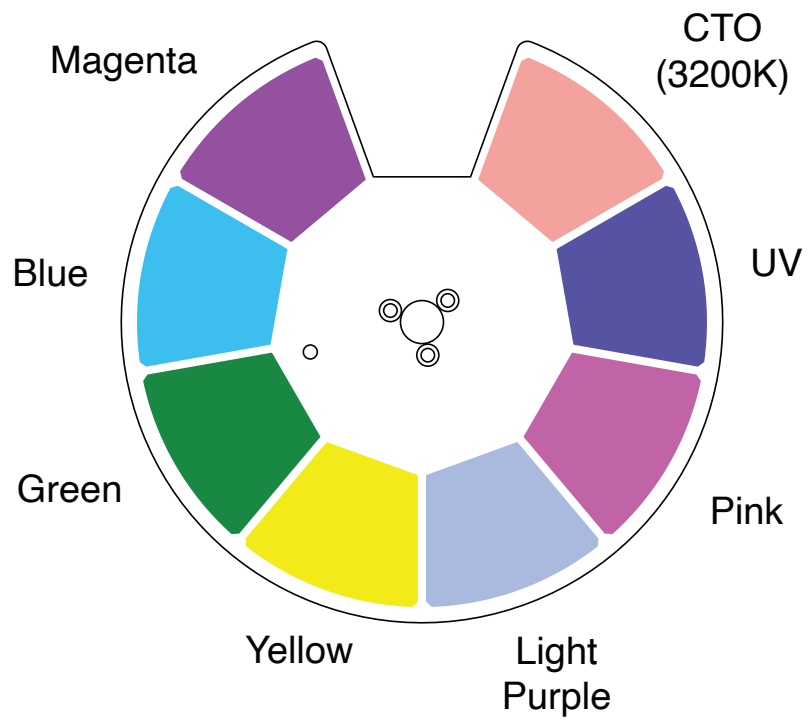

GOBOS

DESIGNS

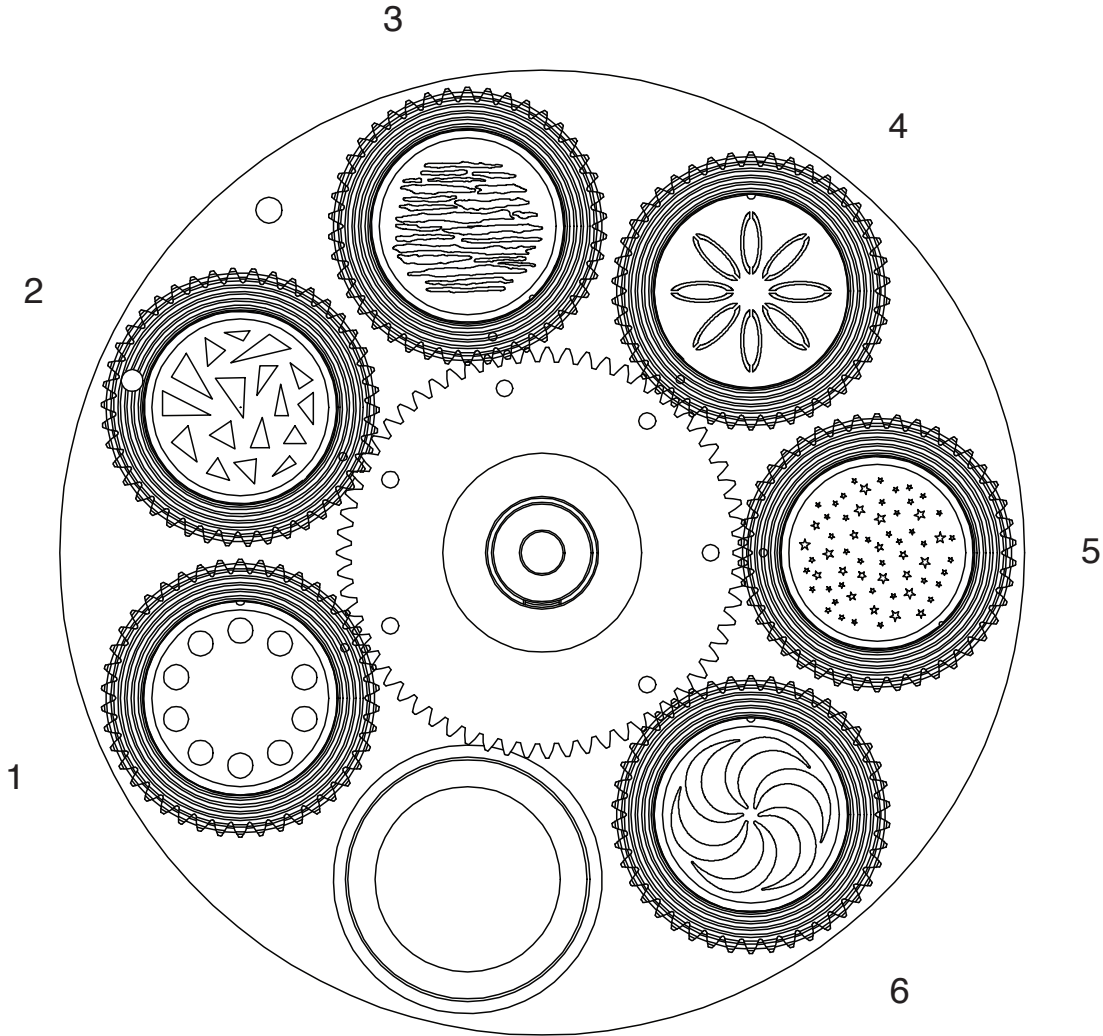

GOBO DIMENSIONS		
Thickness	Inner (Viewable) Diameter	Outer Diameter
0.002in (0.5mm)	0.75in (19.0mm)	0.906in ^{0 in} _{-0.008in} (23.0mm ^{0mm}) _{-0.2mm}

GOBOS

ROTATING GOBO HOLDER DIMENSIONS

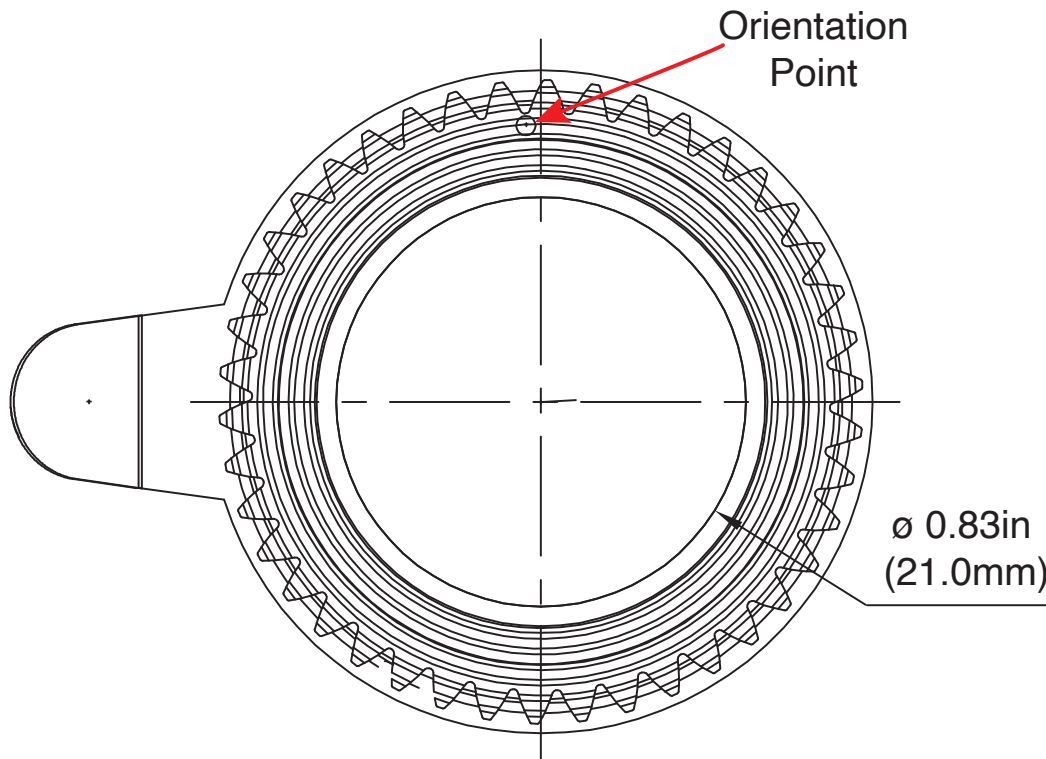
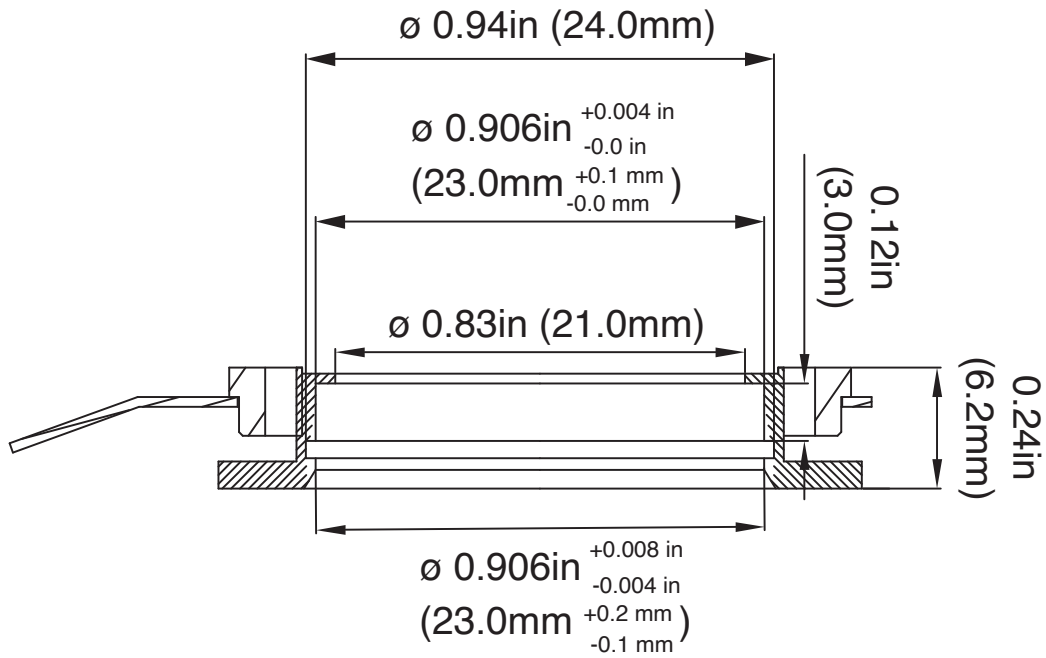

GOBOS

REPLACEMENT PROCEDURE

1. Place the device on a flat, stable surface, and allow the device to cool down for at least 1 hour before beginning this procedure.
2. Remove the head covers.
3. Locate the gobo module, which can be identified by finding the cooling fan located near the middle of the module, as shown in the illustration below. Disconnect any electrical connectors linking the module to the fixture head, and remove the screws holding the module in place. Slide the module out of the head.

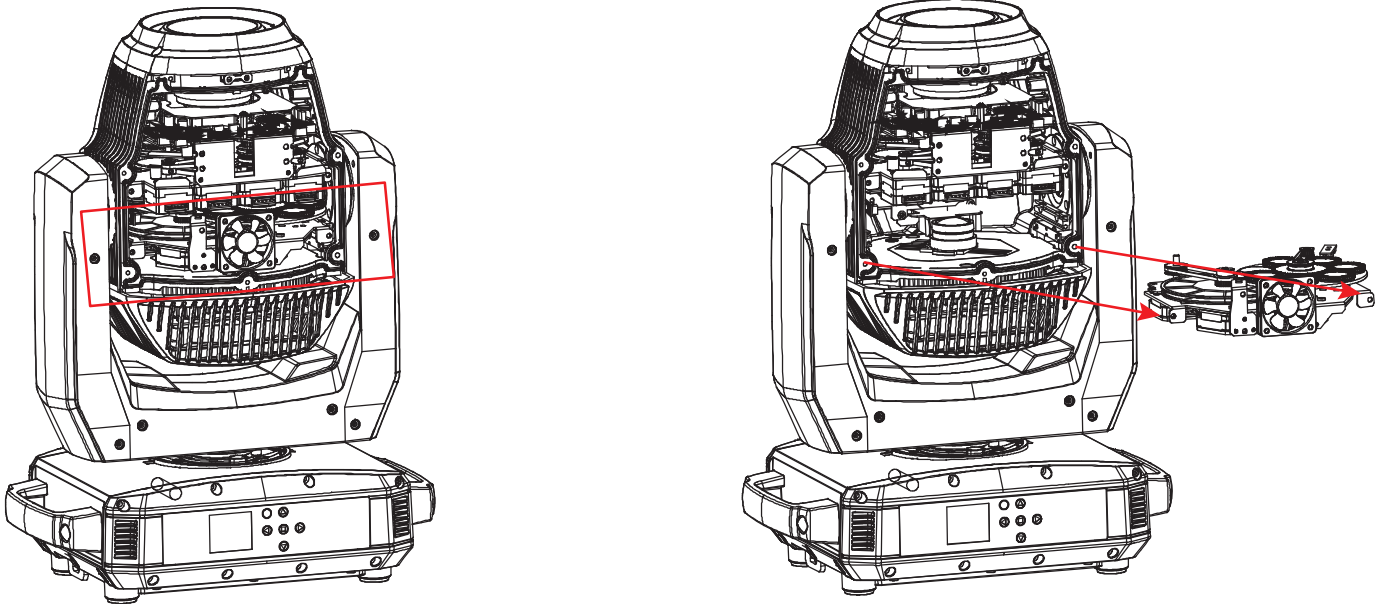

4. Pull the gobo holder away from the gobo wheel, then gently slide it outwards. Use a pair of needle nose pliers to carefully remove the retainer spring from the gobo holder. The gobo can now be removed from the gobo holder, and replaced with a new gobo. Reassemble by reversing these steps.

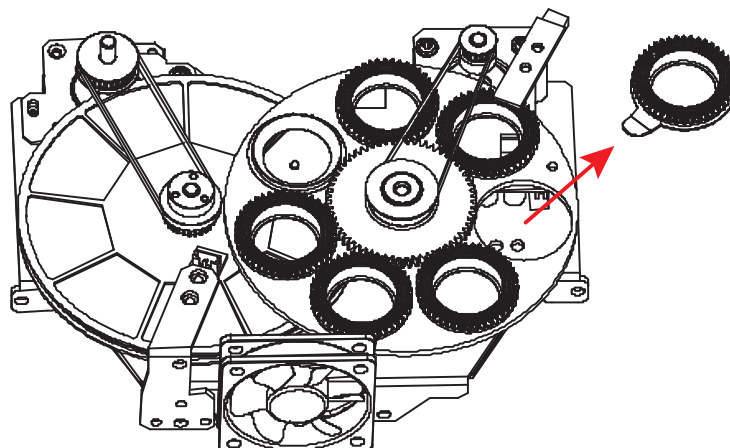

CONTROL PANEL

The Hydro Spot 1 features a display screen with a 6-button control pad, which can be used to easily adjust any device settings.

- The MODE button cycles through main menu options, or returns to the previous menu without making changes.
- The ENTER button is used to select the highlighted option, or to confirm a selection.
- The UP, DOWN, LEFT, and RIGHT buttons are used to navigate and adjust menu options and settings displayed on the screen.

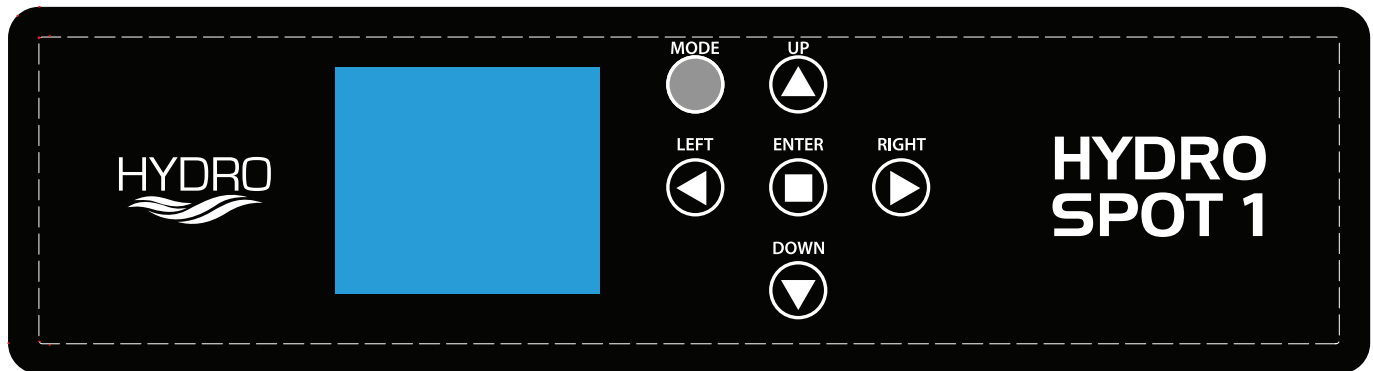

KEY LOCK

This function allows the user to configure whether or not the display screen and control panel keys will lock after a certain period of inactivity. It can be accessed by navigating to **Personality > Display > Key Lock** in the system menu. The setting options are described below:

- **OFF:** The display screen and control panel keys remain active at all times.
- **ON:** The display screen and control panel keys automatically lock after a certain period of inactivity, which can be set under **Personality > Display > Screen Saver Delay**. To unlock, press and hold the **MODE** button for 10 seconds.
- **ON1:** The display screen and control panel keys automatically lock after a certain period of inactivity, which can be set under **Personality > Display > Screen Saver Delay**. To unlock, press **UP, DOWN, UP, DOWN, ENTER** in that order.

BATTERY

This unit features a dedicated battery that can be used to power the screen display. This allows the user to configure the device's channel mode, DMX address, or any other screen-accessible features without needing to power on the device or even connect it to a power source. To activate the display on battery power, press and hold the MODE button for 3 seconds. **Please note that the battery is NOT user-accessible, and the user should NOT attempt to access or replace the battery, as doing so may void your manufacturer's warranty. If battery replacement is required, please contact ADJ service for assistance.**

SYSTEM MENU

DMX SETTINGS	DMX Address	001 - xxx			
	DMX Channel Mode	Basic 17			
		Standard 20			
		Extended 22			
	No DMX Status	Hold Last		Holds last settings when DMX signal is lost	
		Blackout		Takes all channels to 0 when DMX signal is lost	
		Manual		Reverts to manual mode when DMX signal is lost	
Internal Programs		Reverts to selected internal program when DMX signal is lost			
PERSONALITY	Prim/Sec Mode	Primary / Secondary			
	Select Signal	DMX or Wifly		DMX has priority; green LED indicates Wifly connected, and red LED indicates Wifly not connected	
		Wifly and DMX Out		DMX XLR output sends DMX signal out	
	Wifly Settings	Wifly Enable	On / Off		
		Set Wifly Channel	00 - 14		
	Status Settings	Pan Degree	540 / 630		
		Pan Invert	On / Off		
		Tilt Invert	On / Off		
		P/T Feedback	On / Off		Pan/Tilt Feedback
		P/T Speed	Speed 1		Pan/Tilt Speed
			Speed 2		
	Hibernation	Off, 01min - 99 min		Default = 15min	
	Fan Settings	Head Fan	Auto		
			High		
			Low		
		Base Fan	Auto		
High					
Low					
Zoom Speed	Standard				
	Fast				

CONTINUED ON NEXT PAGE

SYSTEM MENU

PERSONALITY (continued)	Dim Modes	Standard			
		Stage			
		TV			
		Architectural			
		Theatre			
		Stage 2			
		Dim Speed	0.1s - 10.0s		
	LED Refresh Rate	900 Hz-1500 Hz, 2500 Hz, 4000 Hz, 5000 Hz, 6000 Hz, 10 KHz, 15 KHz, 20 KHz, 25 KHz		Default = 1200 Hz	
	Dim Curve	Square			
		Linear			
		Inv Squa			
		S Curve			
	Reset Motors	Reset All Motors	Yes / No		
		Pan/Tilt Reset	Yes / No		
			
		Effect Reset	Yes / No		
	Display	Intensity	1 - 10		
		Display Invert	Yes / No		
		Screen Saver Delay	Off - 10 min		Default = 05 min
		Key Lock	Off		Keys do not lock
			On		Press and hold MODE button for 10 sec to unlock keys
			On1		Press Up, Down, Up, Down, Enter to unlock keys
	Service	Passcode = 050	Effect Adjust (Calibration)	Pan 000 - 255	
				Tilt 000 - 255	
				Color1 000 - 255	
				Color2 000 - 255	
				Gobo 000 - 255	
Shutter 000 - 255					
...					
Update Software			Off / On		
Factory Restore Passcode = 011	Off / On				
MANUAL CONTROL	Pan	000 - 255			
	Pan Fine	000 - 255			
	Tilt	000 - 255			
	Tilt Fine	000 - 255			
			

SYSTEM MENU

INTERNAL PROGRAMS	Program 1	Speed	000 - 255			
		Fade	000 - 255			
	Program 2	Speed	000 - 255			
		Fade	000 - 255			
			
	Program 7	Speed	000 - 255			
		Fade	000 - 255			
	INFORMATION	Fixture Life Time	Power On Time	xxxxxx Hours		Total lifetime hours that fixture has been powered on, cannot be reset
P-On Time-R			xxxxxx Hours		Hours powered on since last reset	
P-On Time-Reset			Passcode = 050		Reset hours powered on	
Total LED Time		LED On Time	xxxxxx Hours		Total lifetime hours that LED has been run, cannot be reset	
		LED On Time-R	xxxxxx Hours		Hours LED has been run since last reset	
		LED Hours Reset	Passcode = 050		Reset LED run hours	
Fixture Temps		LEDs	Current	xxx F / xxx C		Displays current LED temp
			Max Resettable	xxx F / xxx C		Max recorded LED temp since last reset
		Base Temp	Current	xxx F / xxx C		Displays current base temp
			Max Resettable	xxx F / xxx C		Max recorded base temp since last reset
		Reset LED Temp	Yes / No	Passcode = 050		
		Reset Base Temp	Yes / No	Passcode = 050		
Fixture Humidity		Head	xxx %			
		Base	xxx %			
Fan Info (RPM)		LED Fan	xxxx RPM LED			
		Base Fan	xxxx RPM			
DMX Values		Pan				
		Pan Fine				
		...				
Error Logs		xxxxx			List errors one by one	
		Reset Error Log	Yes / No	Passcode = 050		
Software Version	U:xxx					

DMX SETUP

DMX-512: DMX is short for Digital Multiplex. This is a universal protocol used as a form of communication between intelligent fixtures and controllers. A DMX controller sends DMX data instructions from the controller to the fixture. DMX data is sent as serial data that travels from fixture to fixture via the DATA “IN” and DATA “OUT” XLR terminals located on all DMX fixtures (most controllers only have a DATA “OUT” terminal).

DMX Linking: DMX is a language allowing all makes and models of different manufacturers to be linked together and operate from a single controller, as long as all fixtures and the controller are DMX compliant. To ensure proper DMX data transmission, try to use the shortest cable path possible when linking several DMX fixtures. The order in which fixtures are connected in a DMX line does not influence the DMX addressing. For example, a fixture assigned a DMX address of 1 may be placed anywhere in a DMX line: at the beginning, at the end, or anywhere in the middle. When a fixture is assigned a DMX address of 1, the DMX controller knows to send DATA assigned to address 1 to that unit, no matter where it is located in the DMX chain.

Data Cable (DMX Cable) Requirements (For DMX Operation): This unit can be controlled via DMX-512 protocol. The DMX address is set on the rear panel of the unit. Your unit and your DMX controller require a standard 5-pin XLR connector for data input and data output. We recommend Accu-Cable DMX cables. If you are making your own cables, be sure to use standard 110-120 Ohm shielded cable (This cable may be purchased at almost all pro lighting stores). Your cables should be made with a male XLR connector at one end and a female XLR connector at the other. Also remember that DMX cable must be daisy chained and cannot be split.

Notice: Be sure to follow the diagram below when making your own cables. Do not use the ground lug on the XLR connector. Do not connect the cable’s shield conductor to the ground lug or allow the shield conductor to come into contact with the XLR’s outer casing. Grounding the shield could cause a short circuit and erratic behavior.

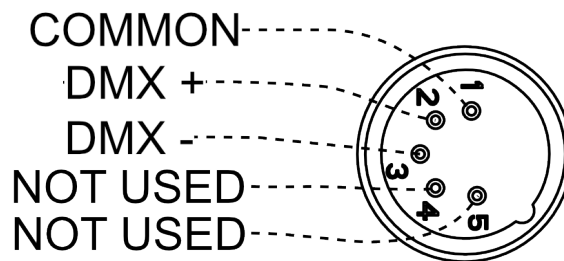

Special Note: Line Termination. When longer runs of cable are used, you may need to use a terminator on the last unit to avoid erratic behavior. A terminator is a 110-120 ohm 1/4 watt resistor which is connected between pins 2 and 3 of a male XLR connector (DATA + and DATA -). This unit is inserted in the female XLR connector of the last unit in your daisy chain to terminate the line. Using a cable terminator (ADJ part number Z-DMX/T) will reduce the risk of erratic behavior.

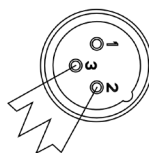
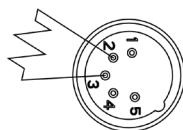

A DMX512 terminator reduces signal errors, avoiding most signal reflection interference. Connect PIN 2 (DMX-) and PIN 3 (DMX+) of the last fixture in series with a 120 Ohm, 1/4 W Resistor to terminate the DMX512.

DMX SETUP

DMX ADDRESSING.

All fixtures should be given a DMX starting address when using a DMX controller, so the correct fixture responds to the correct control signal. This digital starting address is the channel number from which the fixture starts to “listen” to the digital control signal sent out from the DMX controller. The assignment of this starting DMX address is achieved by setting the correct DMX address on the digital control display on the fixture.

You can set the same starting address for all fixtures or a group of fixtures, or set different addresses for each individual fixture. Setting all fixtures to the same DMX address will cause all fixtures to react in the same way. In other words, changing the settings of one channel will affect all the fixtures simultaneously.

If you set each fixture to a different DMX address, each unit will start to “listen” to the channel number you have set, based on the quantity of DMX channels of each fixture. That means changing the settings of one channel will only affect the selected fixture.

For example, when this unit is operating in 17 channel mode, you should set the starting DMX address of the first unit to 1, the second unit to 18 (1 + 17), the third unit to 35 (1 + 17 + 17), and so on. See the chart below for more details.

CHANNEL MODE	UNIT 1 ADDRESS	UNIT 2 ADDRESS	UNIT 3 ADDRESS	UNIT 4 ADDRESS
17 Ch	1	18	35	52
20 Ch	1	21	41	61
22 Ch	1	23	45	67

DMX TRAITS

CHANNEL			DMX VALUES	FUNCTION
17 CH	20 CH	22 CH		
1	1	1	000 - 255	Pan Movement, 540/630
	2	2	000 - 255	Pan Fine
2	3	3	000 - 255	Tilt Movement, 270
	4	4	000 - 255	Tilt Fine
3	5	5		Color Wheel 1
			000 - 009	Open
			010 - 016	Open / Red
			017 - 023	Red
			024 - 030	Red / Medium Blue
			031 - 037	Medium Blue
			038 - 044	Medium Blue / Green
			045 - 051	Green
			052 - 058	Green / Amber
			059 - 065	Amber
			066 - 072	Amber / Orange
			073 - 079	Orange
			080 - 086	Orange / High CRI
			087 - 093	High CRI
			094 - 100	High CRI / CTB (5600K)
			101 - 107	CTB (5600K)
			108 - 114	CTB (5600K) / UV
			115 - 121	UV
			122 - 127	UV / Open
128 - 189	Clockwise Color Wheel Rotation, fast to slow			
190 - 193	No Rotation			
194 - 255	Counter-Clockwise Color Wheel Rotation, slow to fast			
4	6	6		Color Wheel 2
			000 - 009	Open
			010 - 016	Open / Magenta
			017 - 023	Magenta
			024 - 030	Magenta / Blue
			031 - 037	Blue
			038 - 044	Blue / Green
			045 - 051	Green
			052 - 058	Green / Yellow
			059 - 065	Yellow
			066 - 072	Yellow / Light Purple
			073 - 079	Light Purple
			080 - 086	Light Purple / Pink
			087 - 093	Pink
			094 - 100	Pink / UV
			101 - 107	UV
			108 - 114	UV / CTO (3200K)
			115 - 121	CTO (3200K)
			122 - 127	CTO (3200K) / Open
128 - 189	Clockwise Color Wheel Rotation, fast to slow			
190 - 193	No Rotation			
194 - 255	Counter-Clockwise Color Wheel Rotation, slow to fast			

DMX TRAITS

CHANNEL			DMX VALUES	FUNCTION
17 CH	20 CH	22 CH		
5	7	7		Gobo Wheel
			000 - 004	Open
			005 - 019	Gobo 1 - Dotted Tunnel
			020 - 034	Gobo 2 - Scattered Triangles
			035 - 049	Gobo 3 - Swipe
			050 - 064	Gobo 4 - Flower Petals
			065 - 079	Gobo 5 - Starry Night
			080 - 094	Gobo 6 - Swirl
			095 - 109	Gobo 1 Shake, slow to fast
			110 - 124	Gobo 2 Shake, slow to fast
			125 - 139	Gobo 3 Shake, slow to fast
			140 - 154	Gobo 4 Shake, slow to fast
			155 - 169	Gobo 5 Shake, slow to fast
			170 - 189	Gobo 6 Shake, slow to fast
			190 - 221	Clockwise Gobo Wheel Rotation, fast to slow
222 - 223	No Rotation			
224 - 255	Counter-Clockwise Gobo Wheel Rotation, slow to fast			
6	8	8		Gobo Rotation
			000 - 127	Indexing
			128 - 189	Clockwise Gobo Rotation, fast to slow
			190 - 193	No Rotation
194 - 255	Counter-Clockwise Gobo Rotation, slow to fast			
7	9	9		Shutter
			000 - 031	Shutter Closed
			032 - 063	Shutter Open
			064 - 095	Strobe, slow to fast
			096 - 127	Shutter Open
			128 - 159	Pulse Effect, slow to fast
			160 - 191	Shutter Open
			192 - 223	Random Strobe, slow to fast
224 - 255	Shutter Open			
8	10	10	000 - 255	Dimmer Intensity, 0% to 100%
		11	000 - 255	Dimmer Intensity Fine
9	11	12		Prisms and Prism/Gobo Macros
			000 - 005	No Prism - Open
			006 - 066	Prism 1 (5 Facet Linear Prism)
			067 - 127	Prism 2 (6 Facet Circular Prism)
			129 - 135	Macro 1
			136 - 143	Macro 2
			144 - 151	Macro 3
			152 - 159	Macro 4
			160 - 167	Macro 5
			168 - 175	Macro 6
			176 - 183	Macro 7
			184 - 191	Macro 8
			192 - 199	Macro 9
			200 - 207	Macro 10
			208 - 215	Macro 11
			216 - 223	Macro 12
			224 - 231	Macro 13
232 - 239	Macro 14			
240 - 247	Macro 15			
248 - 255	Macro 16			

DMX TRAITS

CHANNEL			DMX VALUES	FUNCTION
17 CH	20 CH	22 CH		
10	12	13		Prism Rotation
			000 - 005	Prism Rotation Off
			006 - 128	Prism Indexing, 0°...540°
			129 - 191	Clockwise Prism Rotation, fast to slow
			192	No Rotation
		193 - 255	Counter-Clockwise Prism Rotation, slow to fast	
11	13	14	000 - 255	Focus , 0% to 100%
12	14	15	000 - 255	Zoom , narrow to wide
		16	000 - 255	Zoom Fine
13	15	17	000 - 255	Heavy Frost , 0% to 100%
14	16	18	000 - 255	Medium Frost , 0% to 100%
15	17	19		Dimmer Modes
			000 - 020	Default to Unit Setting
			021 - 040	Standard
			041 - 060	Stage
			061 - 080	TV
			081 - 100	Architectural
			101 - 120	Theater
			121 - 140	Stage 2
			141 - 160	Dim Speed, fast to slow (0.1s to 10.0s)
		161 - 255	Default to Unit Setting	
	18	20		Dim Curves
			000 - 020	Square
			021 - 040	Linear
			041 - 060	Inv Squa
			061 - 080	S Curve
			081 - 255	No Function
16	19	21		Pan/Tilt Speed
			000 - 225	Pan/Tilt, fast to slow
			226 - 235	Blackout by Movement
			236 - 245	Blackout by All Wheel Changing
			246 - 255	No Function
17	20	22		Special Functioins
			000 - 039	No Function
			040 - 049	Fan Control - Low (hold 3s)
			050 - 059	Fan Control - High (hold 3s)
			060 - 069	Fan Control - Auto (Default, hold 3s)
			070 - 074	All motor reset (hold 3s)
			075 - 079	Pan/tilt reset (hold 3s)
			080 - 084	Color reset (hold 3s)
			085 - 089	Gobo reset (hold 3s)
			090 - 094	Focus and zoom reset (hold 3s)
		095 - 099	Shutter reset (hold 3s)	

DMX TRAITS

CHANNEL			DMX VALUES	FUNCTION
17 CH	20 CH	22 CH		
17	20	22		Special Functions (continued)
			100 - 104	No Function
			105 - 109	Other motors reset (hold 3s)
			110 - 114	Enable Zoom Speed Fast (hold 3s)
			115 - 119	Disable Zoom Speed Fast (hold 5s)
			120 - 148	No function
			149 - 150	Wifly On (Default, hold 3s)
			151 - 152	Wifly Off (hold 5s)
			153 - 154	Hibernation Enable (hold 3s) - see Installation section for details
			155 - 156	Hibernation Off (hold 5s) - see Installation section for details
			157 - 158	Display Backlight On (hold 3s)
			159 - 160	Display Backlight Off (hold 5s)
			161 - 162	Pan/Tilt Speed 1 (default, hold 5s)
			163 - 164	Pan/Tilt Speed 2 (hold 5s)
			165 - 166	Invert Pan On (hold 3s)
			167 - 168	Invert Pan Off (hold 5s)
			169 - 170	Invert Tilt On (hold 3s)
			171 - 172	Invert Tilt Off (hold 5s)
				Refresh Rate (Hz, Hold 1s)
			173	900
			174	910
			175	920
			176	930
			177	940
			178	950
			179	960
			180	970
			181	980
			182	990
			183	1000
			184	1010
			185	1020
			186	1030
187	1040			
188	1050			
189	1060			
190	1070			
191	1080			
192	1090			
193	1100			
194	1110			
195	1120			
196	1130			
197	1140			

DMX TRAITS

CHANNEL			DMX VALUES	FUNCTION
17 CH	20 CH	22 CH		
17	20	22		Refresh Rates (Hz, hold 3s)
			198	1150
			199	1160
			200	1170
			201	1180
			202	1190
			203	1210
			204	1220
			205	1230
			206	1240
			207	1250
			208	1260
			209	1270
			210	1280
			211	1290
			212	1300
			213	1310
			214	1320
			215	1330
			216	1340
			217	1350
			218	1360
			219	1370
			220	1380
			221	1390
			222	1400
			223	1410
			224	1420
			225	1430
			226	1440
			227	1450
			228	1460
229	1470			
230	1480			
231	1490			
232	1500			
233	2500			
234	4000			
235	5000			
236	6000			
237	10,000			
238	15,000			
239	20,000			
240	25,000			
241	Internal Program 1 (scenes 1-8, hold 3s)			
242	Internal Program 2 (scenes 9-16, hold 3s)			
243	Internal Program 3 (scenes 17-24, hold 3s)			
244	Internal Program 4 (scenes 25-32, hold 3s)			
245	Internal Program 5 (scenes 33-40, hold 3s)			
246	Internal Program 6 (scenes 41-48, hold 3s)			
247	Internal Program 7 (scenes 49-56, hold 3s)			
248 - 255	No Function			

DMX SPEEDS

DMX VALUES	DELAY TIME
121	0.1 sec
122	0.2 sec
123	0.3 sec
124	0.4 sec
125	0.5 sec
126	0.6 sec
127	0.7 sec
128	0.8 sec
129	0.9 sec
130	1.0 sec
131	1.5 sec
132	2.0 sec
133	3.0 sec
134	4.0 sec
135	5.0 sec
136	6.0 sec
137	7.0 sec
138	8.0 sec
139	9.0 sec
140	10.0 sec

DIM MODES

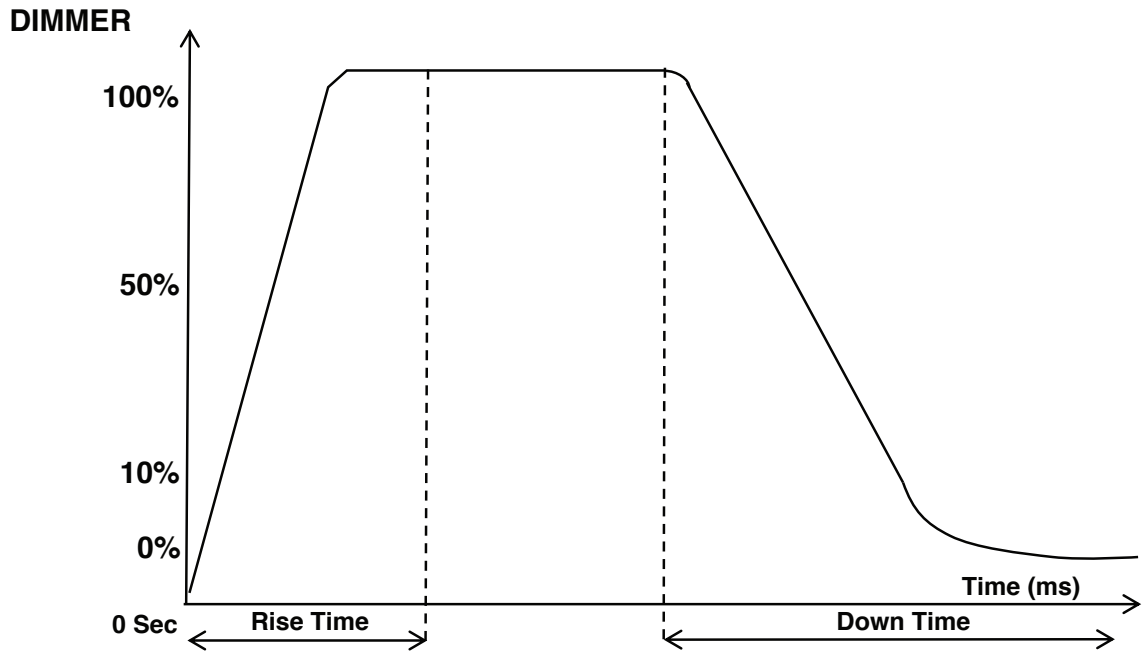

Dimming Curve Ramp Effect	0 sec Fade Time		1 sec Fade Time	
	Rise Time (ms)	Down Time (ms)	Rise Time (ms)	Down Time (ms)
Standard (default)	0	0	0	0
Stage	780	1100	1540	1660
TV	1180	1520	1860	1940
Architectural	1380	1730	2040	2120
Theatre	1580	1940	2230	2280
Stage 2	0	1100	0	1660

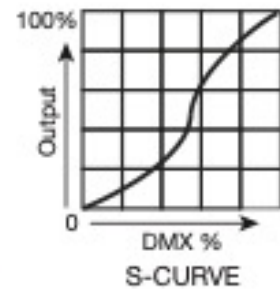
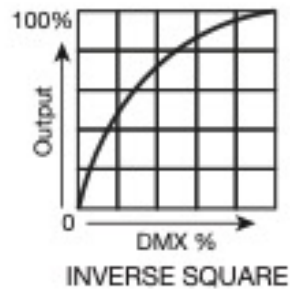
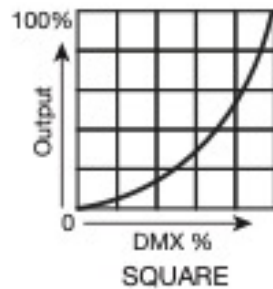
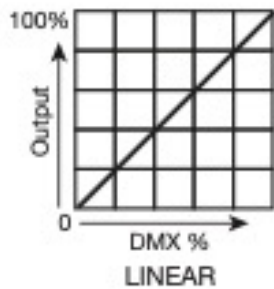

PRIMARY-SECONDARY SETUP

This function allows you to link units together to run in a Primary-Secondary set-up, in which one unit will act as the controlling unit and the others will react to the controlling unit's built-in programs. Any unit can be configured to act as a Primary or as a Secondary, but only one unit in a given system can be programmed to act as the Primary.

Primary-Secondary Connections and Settings:

1. Daisy chain your units via the XLR connectors on the rear panels of each unit. Use standard XLR data cables to link your units together. Remember that the male XLR connector is the input and the female XLR connector is the output. The first unit in the chain (primary) will use the female XLR connector only, while the last unit in the chain will use the male XLR connector only.
2. Use the display screen and control panel to navigate to Personality > Prim/Sec Mode. Select this sub-menu using the ENTER button, and use the arrows to toggle between "Primary" and "Secondary". Press ENTER to confirm your selection.
3. Repeat Step 2 for each unit in the system. Make sure that only one unit is designated as the Primary, while all other units are designated as Secondaries.
4. The secondary units will now follow the behavior of the primary unit.

MULTI UNIT POWER LINKING

This feature allows you to connect the fixtures to one another using the power cable input and output sockets.

The maximum number of units that can be linked in this manner is as follows:

- 3 units when running on 110V power.
- 8 units when running on 240V power.

DO NOT EXCEED THIS MAXIMUM NUMBER WHEN POWER LINKING UNITS!

All linked units must be of the same make and model type. Do not mix and match units!

MAINTENANCE GUIDELINES



DISCONNECT POWER BEFORE PERFORMING ANY MAINTENANCE!

CLEANING

Frequent cleaning is recommended to ensure proper function, optimized light output, and an extended life. The frequency of cleaning depends on the environment in which the fixture operates: damp, smoky, or particularly dirty environments can cause greater accumulation of dirt on the fixture's optics. Clean the external lens surface regularly with a soft cloth to avoid dirt/debris accumulation.

NEVER use alcohol, solvents, or ammonia-based cleaners.

MAINTENANCE

Regular inspections are recommended to ensure proper function and extended life. There are no user serviceable parts inside this fixture. Please refer all other service issues to an authorized ADJ service technician. Should you need any spare parts, please order genuine parts from your local ADJ dealer.

Please refer to the following points during routine inspections:

- A. A detailed electrical check by an approved electrical engineer every three months, to make sure the circuit contacts are in good condition and prevent overheating.
- B. Be sure all screws and fasteners are securely tightened at all times. Loose screws may fall out during normal operation, resulting in damage or injury as larger parts could fall.
- C. Check for any deformations on the housing, color lenses, rigging hardware, and rigging points (ceiling, suspension, trussing). Deformations in the housing could allow for dust to enter into the fixture. Damaged rigging points or unsecured rigging could cause the fixture to fall and seriously injure a person(s).
- D. Electric power supply cables must not show any damage, material fatigue, or sediments.

NEVER remove the ground prong from the power cable.

SOFTWARE UPDATES

For software updates, please contact ADJ service to obtain a software uploader and detailed instructions. Refer to the **Introduction** section of this manual for contact information.

FIXTURE DISASSEMBLY

The following points should be observed after performing any maintenance procedure that requires disassembly of the unit:

- After the unit has been reassembled, open the valve, and allow the light to run for approximately 2 hours in order to dry out any moisture that has been trapped inside the fixture. The process should continue until indicated humidity drops below 15% for the head and 30% for the base.
- Once this has been achieved, the light can be switched off, but the unit should remain connected to power so that the cooling fan can cool down the unit. Please note that allowing cool down time should **ALWAYS** be done after lamp operation.
- Some units may require partial disassembly in order to gain access to the valve. Please contact ADJ service for information regarding the location and access procedure for the valve on your specific unit model.

TORQUE SETTINGS FOR SCREWS

ALL SCREWS MUST BE TIGHTENED WITH A TORQUE DRIVER. All screws are Allen head screws. Please refer to the table and diagram below for screw locations, quantity, and torque settings.

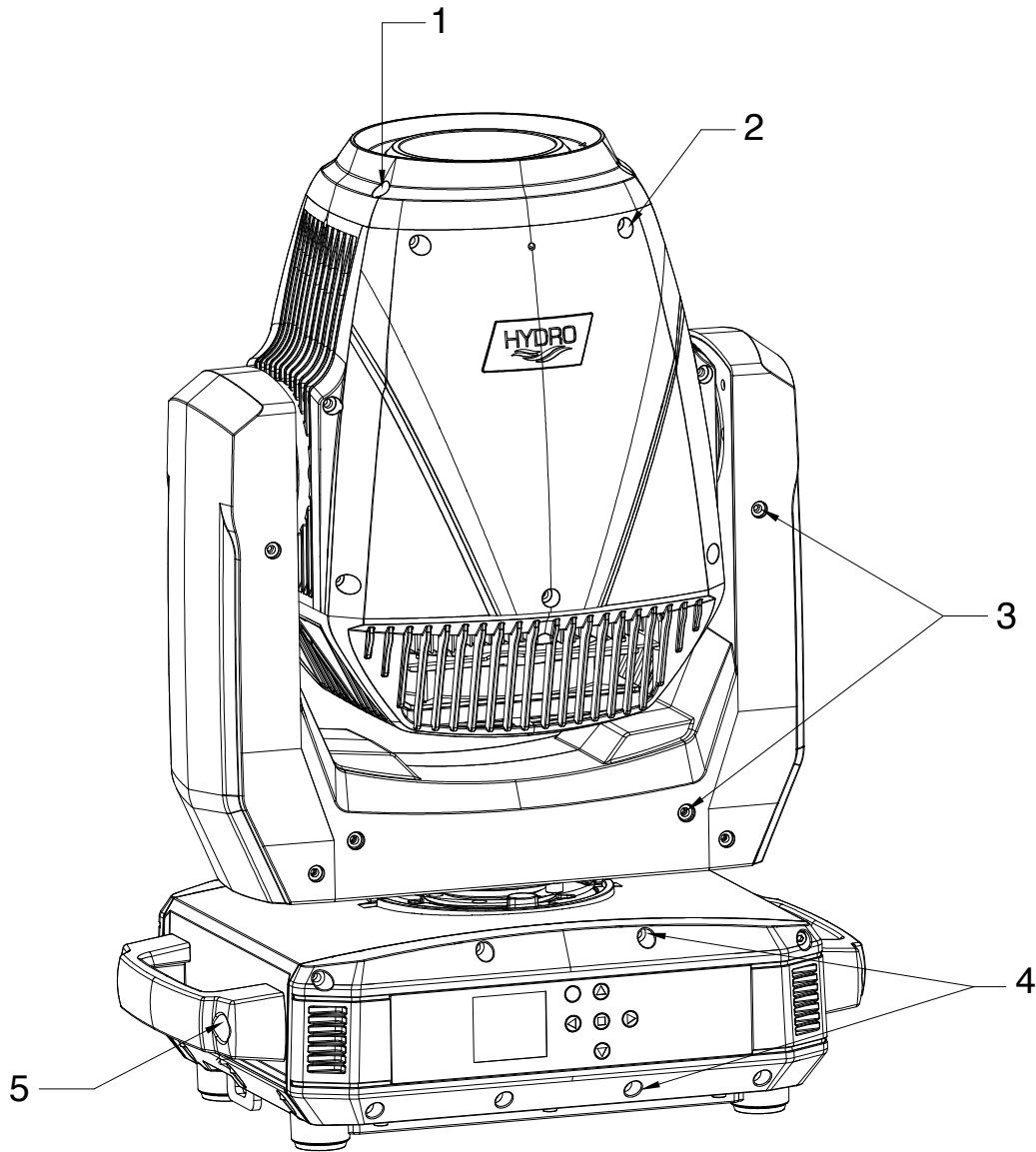

Zone No.	Description	Quantity	Torque Spec
1	Lens Frame	4	4.3 ± 0.6 in-lb (5.0 ± 0.7 Kg-cm)
2	Main Head Cover	7 per side (14 total)	6.9 ± 0.6 in-lb (8.0 ± 0.7 Kg-cm)
3	Arm Cover	6 per side (12 total)	4.3 ± 0.4 in-lb (5.0 ± 0.5 Kg-cm)
4	Base Side Cover	8 per side (16 total)	6.9 ± 0.6 in-lb (8.0 ± 0.7 Kg-cm)
5	Carry Handle	2 per handle (4 total)	6.9 ± 0.6 in-lb (8.0 ± 0.7 Kg-cm)

TORQUE SETTINGS FOR SCREWS

TORQUE DRIVERS (Recommended): UTICA TS-30 (Shown)

TORQUE DRIVER (Alternate):

- Proto J6107A
- Wiha 28887



CAUTION! DO NOT OVER TORQUE SCREWS AS THIS CAN CAUSE LEAKAGE ISSUES! TO CONFIRM THE IP65 INTEGRITY AFTER A LAMP REPLACEMENT, TEST THE FIXTURE USING THE IP TESTER. CONTACT ADJ SERVICE FOR MORE DETAILS.



CAUTION! THE USE OF PROTECTIVE GLOVES AND SAFETY GOGGLES IS STRONGLY RECOMMENDED WHILE PERFORMING THE IP PRESSURE TEST! AVOID PLACING YOUR FACE, EYES, HANDS, ETC IN CLOSE PROXIMITY TO THE FIXTURE'S LENS WHILE PERFORMING THE TEST!



IP PRESSURE TESTING PARAMETERS		
Maximum Pressure	Minimum Pressure	Steady/Hold Time
3.3 psi (23 KPa)	2.9 psi (20 KPa)	15 sec

ERROR CODES

When power is applied, the unit will automatically enter a “**Reset/Test**” mode. This mode brings all the internal motors to a home position. If there is an internal problem with one or more of the motors, an error code will flash in the display, as described in the chart below. For example, when the display shows “Pan” it means there is some type of error with the Pan motor. If there are multiple errors during the start-up process, they will all flash in the display. For example: if the fixtures have errors on Pan, Tilt, and Color Wheel 1 all at the same time, you will see the error message “Pan”, “Tilt”, and “Color Wheel 1” flash repeated 5 times.

If an error does occur during the initial start-up procedure, the fixture will self-generate a second reset signal and try to realign all the motors and correct the errors. If the error persists after a second attempt, a third attempt will be made. If after a third attempt all the errors have not been corrected, the fixture will make the following determinations:

- **3 or More Errors:** The fixture cannot function properly with three or more errors. Therefore the fixture will place itself in a stand-by mode until subsequent repairs can be made.
- **Less Than 3 Errors:** The fixture has less than 3 errors. Therefore, most other functions will work properly. The fixture will attempt to operate normally until the errors can be correct by a technician. The errors in question will remain flashing in the display as a reminder of internal errors.

Error Code	Description
Pan	Pan Error
Tilt	Tilt Error
Color Wheel 1	Color Wheel 1 Error
Color Wheel 2	Color Wheel 2 Error
Focus	Focus Error
Zoom	Zoom Error
Gobo	Gobo Wheel Error
Rot Gobo	Gobo Rotation Error
Prism 1	Prism 1 Error
Prism 1 Rot	Prism 1 Rotation Error
Prism 2	Prism 2 Error
Prism 2 Rot	Prism 2 Rotation Error
LED Fan	LED Fan Error
Base Fan	Base Fan Error
LED Temp	LED Temperature Error
Base Temp	Base Temperature Error

DIMENSIONAL DRAWINGS

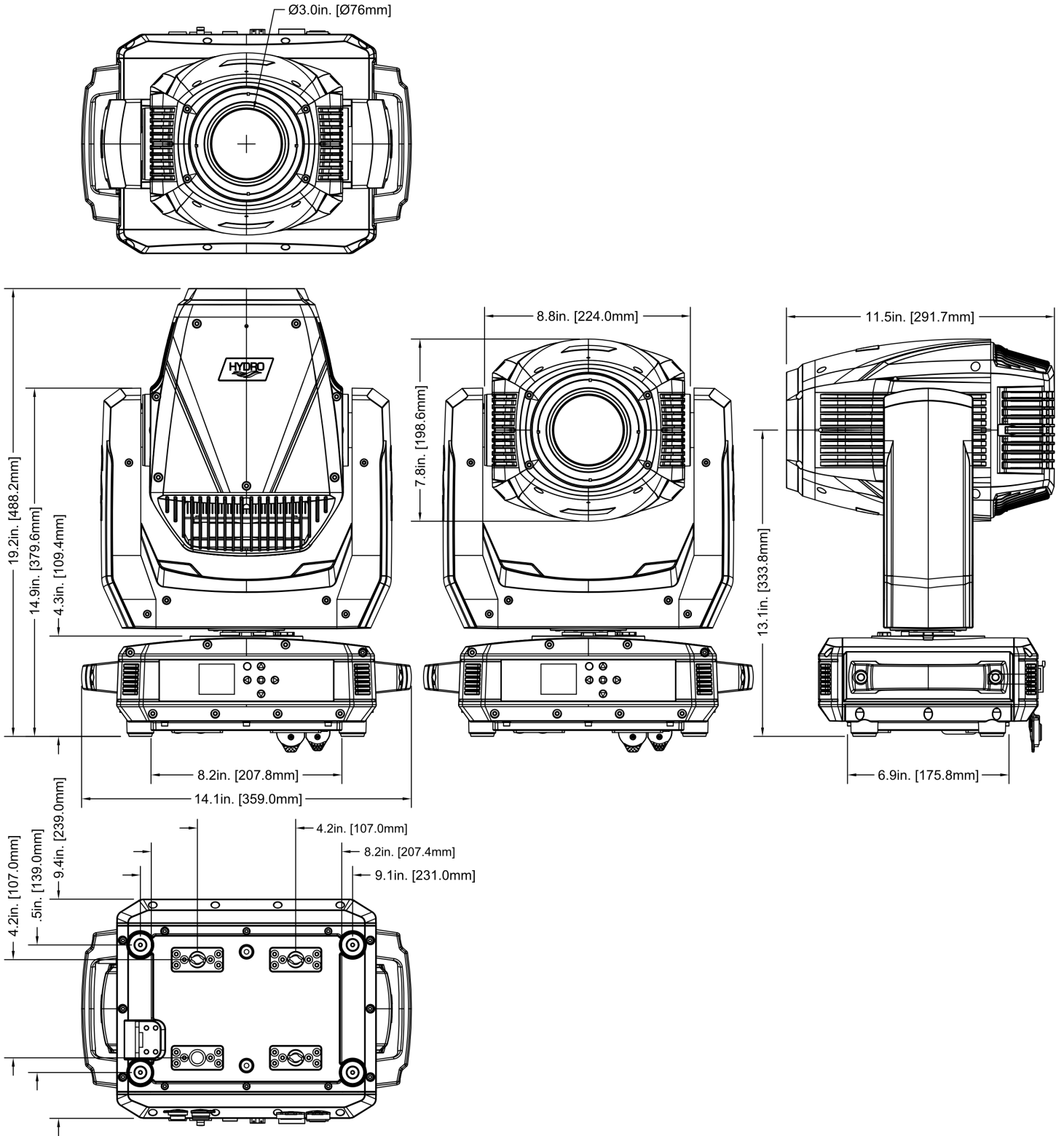

SPECIFICATIONS

Light Source:

- 200W Cool White LED Engine (50,000 hr.)

Features:

- Wifly EXR (Wireless DMX)
- Motorized Focus
- Motorized Zoom: 12° ~ 23°
- 2 Frost Filters (Heavy and Medium)
- 2 Prism FX: Rotating 5-facet Linear & rotating 6-facet Circular
- 0-100% smooth dimming
- Various strobe speeds
- 2 cooling fans

Color Wheels:

- (2) Color wheels
- 8 dichroic colors + white on each wheel (includes CTO, CTB and UV filters)

GOBO Wheels:

- (1) Wheel with 6 Rotatable Gobos
- All Gobos are replaceable
- Gobo Shake Effect
- Aluminum GOBO size: 23mm (outer); 19mm (viewable); 0.5mm (thickness)
- Glass gobo size: 23mm (outer); 19mm (viewable); 3.3mm (thickness)

Prism Wheel:

- Prism Wheel 1: Rotatable 6-facet Circular
- Prism Wheel 2: Rotatable 5-facet Linear
- Both Prisms are indexable

Frost Filters:

- Frost 1: Heavy frost for wash effect
- Frost 2: Medium frost creates lightly blurred edges for Gobo and Prism FX

Control:

- 3 DMX Channel Modes: 17/20/22
- Wifly EXT (Wireless DMX)
- Color LCD display with 6-button function menu
- Control Mode: DMX512 or internal programs
- 6 Dim Modes: Standard, Stage, TV, Architectural, Theatre, Stage2
- 4 Dim Curves: Square, Linear, Inv. Square and S. Curve
- Selectable LED Refresh Rates (900 Hz~25K Hz)
- 0-100% smooth dimming
- Various strobe speeds
- RDM (Remote Device Management)
- With Wired Digital Communication Network

Pan/Tilt:

- Pan: 630 degrees
- Tilt: 270 degrees

Connections:

- DMX Connections: 5-pin XLR In/Out
- Power Connections: IP65 PowerLock In/Out to daisy chain power

Electrical:

- Multi-voltage operation: 90-240V, 50/60Hz
- Max power consumption: 280W
- Min/Max Ambient Temperature: -20°C ~ 45°C

Dimensions & Weight:

- Dimensions (LxWxH): 9.4" x 14.1" x 19.2" (239.0mm x 357.0mm x 488.2mm)
- Weight: 35.2lbs (16kg)

Approvals / Rating:

- ETL Certified
- CE Certified
- IP65 with Marine Coated Exterior and conformal coated PCBs (For temporary outdoor use only!)



Please Note: Specifications and improvements in the design of this unit and this manual are subject to change without any prior written notice.

