



# ENCORE LP32IP



**User Manual**

©2022 ADJ Products, LLC all rights reserved. Information, specifications, diagrams, images, and instructions herein are subject to change without notice. ADJ Products, LLC logo and identifying product names and numbers herein are trademarks of ADJ Products, LLC. Copyright protection claimed includes all forms and matters of copyrightable materials and information now allowed by statutory or judicial law or hereinafter granted. Product names used in this document may be trademarks or registered trademarks of their respective companies and are hereby acknowledged. All non-ADJ Products, LLC brands and product names are trademarks or registered trademarks of their respective companies.

ADJ Products, LLC and all affiliated companies hereby disclaim any and all liabilities for property, equipment, building, and electrical damages, injuries to any persons, and direct or indirect economic loss associated with the use or reliance of any information contained within this document, and/or as a result of the improper, unsafe, insufficient and negligent assembly, installation, rigging, and operation of this product.

## DOCUMENT VERSION



Due to additional product features and/or enhancements, an updated version of this document may be available online.

Please check [www.adj.com](http://www.adj.com) for the latest revision/update of this manual before beginning installation and/or programming.

Date	Document Version	Software Version	DMX Channels	Notes
06/24/2022	1.0	1.01	4 / 7 / 8 / 13 / 16 / 32 / 35 / 41 / 44 / 64 ch.	Initial Release
07/28/2022	1.1	N/C	No Change	Updated specifications

### Europe Energy Saving Notice

Energy Saving Matters (EuP 2009/125/EC)

Saving electric energy is a key to help protecting the environment. Please turn off all electrical products when they are not in use. To avoid power consumption in idle mode, disconnect all electrical equipment from power when not in use. Thank you!

## TABLE OF CONTENTS

Introduction	4
Limited Warranty (USA Only)	5
Warranty Registration   Features	6
Safety Precautions	7
Overview	8
Installation	9
Wireless Setup	15
Remote Device Management (RDM)	16
Control Panel	17
System Menu	18
DMX Set Up	22
DMX Traits	24
Pixel Zones	29
Color Macros Chart	30
Dim Speeds	32
Dim Modes	33
Primary-Secondary Set Up   Multi Unit Power Linking	34
Maintenance Guidelines	35
Dimensional Drawings	36
Specifications	38

## INTRODUCTION

**Unpacking:** Thank you for purchasing the Encore LP32IP by ADJ Products, LLC. Every device has been thoroughly tested and has been shipped in perfect operating condition. Carefully check the shipping carton for damage that may have occurred during shipping. If the carton appears to have been damaged, carefully inspect your fixture for any damage and be sure all accessories necessary to operate the unit have arrived intact. In the event that damage has been found or parts are missing, please contact our toll free customer support number for further instructions. Do not return this unit to your dealer without first contacting customer support.

**Introduction:** The Encore LP32IP is a multi-functional IP65-rated professional wash lighting fixture. It features 32 x 20-Watt 4-in-1 (red, green, blue, lime) color mixing LEDs arranged into 8 individually controllable sections.. **This product is intended to be used by professionally trained personnel only and is not suitable for private use.**

**Customer Support:** Contact ADJ Service for any product related service and support needs. Also visit [forums.adj.com](http://forums.adj.com) with questions, comments or suggestions.

**Parts:** To purchase parts online visit:

<http://parts.adj.com> (US)

<http://www.adjparts.eu> (EU)

**ADJ SERVICE USA - Monday - Friday 8:00am to 4:30pm PST**

Voice: 800-322-6337 | Fax: 323-582-2941 | [support@adj.com](mailto:support@adj.com)

**ADJ SERVICE EUROPE - Monday - Friday 08:30 to 17:00 CET**

Voice: +31 45 546 85 60 | Fax: +31 45 546 85 96 | [support@adj.eu](mailto:support@adj.eu)

### ADJ PRODUCTS LLC USA

6122 S. Eastern Ave. Los Angeles, CA. 90040

323-582-2650 | Fax 323-532-2941 | [www.adj.com](http://www.adj.com) | [info@adj.com](mailto:info@adj.com)

### ADJ SUPPLY Europe B.V

Junostraat 2 6468 EW Kerkrade, The Netherlands

+31 (0)45 546 85 00 | Fax +31 45 546 85 99

[www.americandj.eu](http://www.americandj.eu) | [info@americandj.eu](mailto:info@americandj.eu)

### ADJ PRODUCTS GROUP Mexico

AV Santa Ana 30 Parque Industrial Lerma, Lerma, Mexico 52000

+52 (728) 282-7070

**CAUTION!** There are no user serviceable parts inside this unit. Do not attempt any repairs yourself, as doing so will void your manufacturer's warranty. In the unlikely event your unit may require service, please contact ADJ Products, LLC.

*Do not discard the shipping carton in the trash. Please recycle when ever possible.*

## LIMITED WARRANTY (USA ONLY)

- A. ADJ Products, LLC hereby warrants, to the original purchaser, ADJ Products, LLC products to be free of manufacturing defects in material and workmanship for a prescribed period from the date of purchase (see specific warranty period on reverse). This warranty shall be valid only if the product is purchased within the United States of America, including possessions and territories. It is the owner's responsibility to establish the date and place of purchase by acceptable evidence, at the time service is sought.
- B. For warranty service, you must obtain a Return Authorization number (RA#) before sending the product back—please contact ADJ Products, LLC Service Department at 800-322-6337. Send the product only to the ADJ Products, LLC factory. All shipping charges must be prepaid. If the requested repairs or service (including parts replacement) are within the terms of this warranty, ADJ Products, LLC will pay return shipping charges only to a designated point within the United States. If the entire instrument is sent, it must be shipped in its original package and packaging material. No accessories should be shipped with the product. If any accessories are shipped with the product, ADJ Products, LLC shall incur no liability whatsoever for loss of or damage to any such accessories, nor for the safe return thereof.
- C. This warranty is void if the product serial number and/or labels are altered or removed; if the product is modified in any manner which ADJ Products, LLC concludes, after inspection, affects the reliability of the product; if the product has been repaired or serviced by anyone other than the ADJ Products, LLC factory unless prior written authorization was issued to purchaser by ADJ Products, LLC; if the product is damaged because it was not properly maintained as set forth in the product instructions, guidelines and/or user manual.
- D. This is not a service contract, and this warranty does not include maintenance, cleaning, or periodic check-up. During the period specified above, ADJ Products, LLC will replace defective parts at its expense with new or refurbished parts, and will absorb all expenses for warranty service and repair labor by reason of defects in material or workmanship. The sole responsibility of ADJ Products, LLC under this warranty shall be limited to the repair of the product, or replacement thereof, including parts, at the sole discretion of ADJ Products, LLC. All products covered by this warranty were manufactured after August 15, 2012, and bear identifying marks to that effect.
- E. ADJ Products, LLC reserves the right to make changes in design and/or improvements upon its products without any obligation to include these changes in any products theretofore manufactured.
- F. No warranty, whether expressed or implied, is given or made with respect to any accessory supplied with products described above. Except to the extent prohibited by applicable law, all implied warranties made by ADJ Products, LLC in connection with this product, including warranties of merchantability or fitness, are limited in duration to the warranty period set forth above. And all warranties, whether expressed or implied, including warranties of merchantability or fitness, are limited in duration to the warranty period set forth above. The consumer's and/or dealer's sole remedy shall be such repair or replacement as is expressly provided above; and under no circumstances shall ADJ Product, LLC be liable for any loss and/or damage, direct and/or consequential arising out of the use of, and/or inability to use this product.
- G. This warranty is the only written warranty applicable to ADJ Products, LLC products, and supersedes all prior warranties and written descriptions of warranty terms and conditions heretofore published.

### MANUFACTURER'S LIMITED WARRANTY PERIODS:

- Non-LED Lighting Products = 1-Year (365 Days) (Including Special Effect Lighting, Intelligent Lighting, UV lighting, Strobes, Fog Machines, Bubble Machines, Mirror Balls, Par Cans, Trussing, Lighting Stands, Power/Data Distribution, etc. excluding LED and lamps)
- Laser Products = 1-Year (365 Days) (excluding laser diodes which have a 6-Month Limited Warranty)
- LED Products = 2-Year (730 Days) (excluding batteries which have a 180 Day Limited Warranty)
- NOTE: 2-Year (730 Days) Limited Warranty ONLY applies to product purchased within the United States. StarTec Series = 1-Year (365 Days) (excluding batteries which have a 180 Day Limited Warranty)
- ADJ DMX Controllers = 2 Year (730 Days)
- American Audio Products = 1 Year (365 Days)

## WARRANTY REGISTRATION

Please fill out the enclosed warranty card to validate your purchase. All returned service items, whether under warranty or not, must be freight pre-paid and accompanied by a return authorization (R.A.) number. The R.A. number must be clearly written on the outside of the return package. A brief description of the problem as well as the R.A. number must also be written down on a piece of paper included in the shipping carton. If the unit is under warranty, you must provide a copy of your proof of purchase invoice. You may obtain an R.A. number by contacting our customer support team. All packages returned to the service department not displaying an R.A. number on the outside of the package will be returned to the shipper.

## FEATURES

- 32 x 20-Watt 4-in-1 (red, green, blue, lime) color mixing LEDs
- 8 individually controllable sections
- 10.5 degree concise beam angle
- Diffusion filter and magnetic filter frame allows widening of beam angle to 24.8 degrees
- Suitable for use indoors or outdoors

## INCLUDED ITEMS

- Frost Filter (x1)
- Power Cable (x1)

## IP RATING

An IP rated lighting fixture is commonly installed in outdoor environments and has been designed with an enclosure that effectively protects the ingress (entry) of external foreign objects such as dust and water. The Ingress Protection (IP) rating system is commonly expressed as “IP” followed by two numbers (i.e. IP65), where the numbers define the degree of protection. The first digit (Foreign Bodies Protection) indicates the extent of protection against particles entering the fixture and the second digit (Water Protection) indicates the extent of protection against water entering the fixture. **An IP65 rated lighting fixture, such as this one, has been designed and tested to protect against the ingress of dust (6) and low-pressure water jets from any direction (5).**

## SAFETY PRECAUTIONS



**PROTECTION CLASS 1 - FIXTURE MUST BE PROPERLY GROUNDED.**



**THERE ARE NO USER SERVICEABLE PARTS INSIDE THIS UNIT. DO NOT ATTEMPT ANY REPAIRS YOURSELF, AS DOING SO WILL VOID YOUR MANUFACTURER'S WARRANTY. DAMAGES RESULTING FROM MODIFICATIONS TO THIS FIXTURE AND/OR THE DISREGARD OF SAFETY INSTRUCTIONS AND GUIDELINES IN THIS MANUAL VOID THE MANUFACTURER'S WARRANTY AND ARE NOT SUBJECT TO ANY WARRANTY CLAIMS AND/OR REPAIRS.**



**NEVER LOOK DIRECTLY INTO THE LIGHT SOURCE!  
RETINA INJURY RISK - MAY INDUCE BLINDNESS!  
SENSITIVE PERSONS MAY SUFFER AN EPILEPTIC SHOCK!**

- **Maximum ambient operating temperature is 113° F (45° C)!**
- DO NOT TOUCH the fixture housing during operation. Disconnect the power and allow approximately 15 minutes for the fixture to cool down before servicing.
- DO NOT shake the fixture, and avoid brute force when installing and/or operating the fixture.
- DO NOT operate the fixture if the power cord has become frayed, crimped and/or damaged. If the power cord is damaged, replace immediately with a new one of the same power rating.
- DO NOT attempt to remove or break off the ground prong from the electrical cord. This prong is used to reduce the risk of electrical shock and fire in case of an internal short.
- DO NOT attempt to operate this unit if it has been damaged in any way.
- DO NOT spill water or other liquids into or on to your unit.
- Disconnect from main power before making any type of connection.
- DO NOT block any air ventilation slots. All fan and air inlets must remain clean and never blocked. Allow approx. 6" (15cm) between fixture and other devices or a wall for proper cooling.
- Always be sure to mount this unit in an area that will allow proper ventilation. Allow about 6" (15cm) between this device and a wall.
- DO NOT remove the cover for any reason.
- When installing fixture in a suspended environment, always use mounting hardware that is no less than M10 x 25mm, and always install fixture with an appropriately rated safety cable.
- Never plug this unit in to a dimmer pack.
- During long periods of non-use, disconnect the unit's main power.
- Always mount this unit in safe and stable matter.
- Power-supply cords should be routed so that they are not likely to be walked on or pinched by items placed upon or against them, paying particular attention to the point where they exit from the unit.
- Cleaning - The fixture should be cleaned only as recommended by the manufacturer.
- Heat - The appliance should be situated away from heat sources such as radiators, heat registers, stoves, or other appliances (including amplifiers) that produce heat.
- The fixture should be serviced by qualified service personnel when:
  - A. The power-supply cord or the plug have been damaged.
  - B. Objects have fallen onto, or liquid has been spilled into, the fixture.
  - C. The fixture does not appear to operate normally or exhibits a marked change in performance.
  - D. The fixture has fallen and/or has been subjected to extreme handling.

# OVERVIEW





## INSTALLATION



**DO NOT INSTALL THE FIXTURE IF YOU ARE NOT QUALIFIED TO DO SO!**

Fixture **MUST** be installed following all local, national, and country commercial electrical and construction codes and regulations.

When installing the unit, the trussing or area of installation must be able to hold 10 times the weight of the unit and any attached accessories without any deformation. The unit must be secured with a secondary safety attachment, e.g. an appropriately-rated safety cable.

Before rigging/mounting a single fixture to any metal truss/structure or placing the fixture(s) on any surface, a professional equipment installer **MUST** be consulted to determine if the metal truss/structure or surface is properly certified to safely hold the combined weight of the fixture(s), clamps, cables, and accessories.

Maximum ambient operating temperature is **113°F (45°C)**.

Fixture(s) should be installed away from walking paths, seating areas, or areas where unauthorized personnel might reach the fixture by hand.

**NEVER** stand directly below the fixture(s) when rigging, removing, or servicing.

Overhead fixture installation must always be secured with a secondary safety attachment, such as an appropriately rated safety cable that can hold 10 times the weight of the fixture.

Overhead mounting requires extensive experience, including calculating working load limits, knowledge of installation material being used, and periodic safety inspection of all installation material as well as the unit itself. If you lack these qualifications, do not attempt the installation yourself.

The installation should be checked by a skilled person once a year.

# INSTALLATION

## CLAMP MOUNTING

This fixture features two mounting points for the attachment of an Omega bracket, which are located on the adjustable mounting yoke. Additionally, the unit also features two safety cable loops on the rear face (see the illustration below). When mounting the fixture to a truss or any other suspended or overhead installation, be sure to secure an appropriately rated clamp (not included) to the Omega bracket, and attach a separate **SAFETY CABLE** of the appropriate weight rating to at least one of the provided safety cable loops.

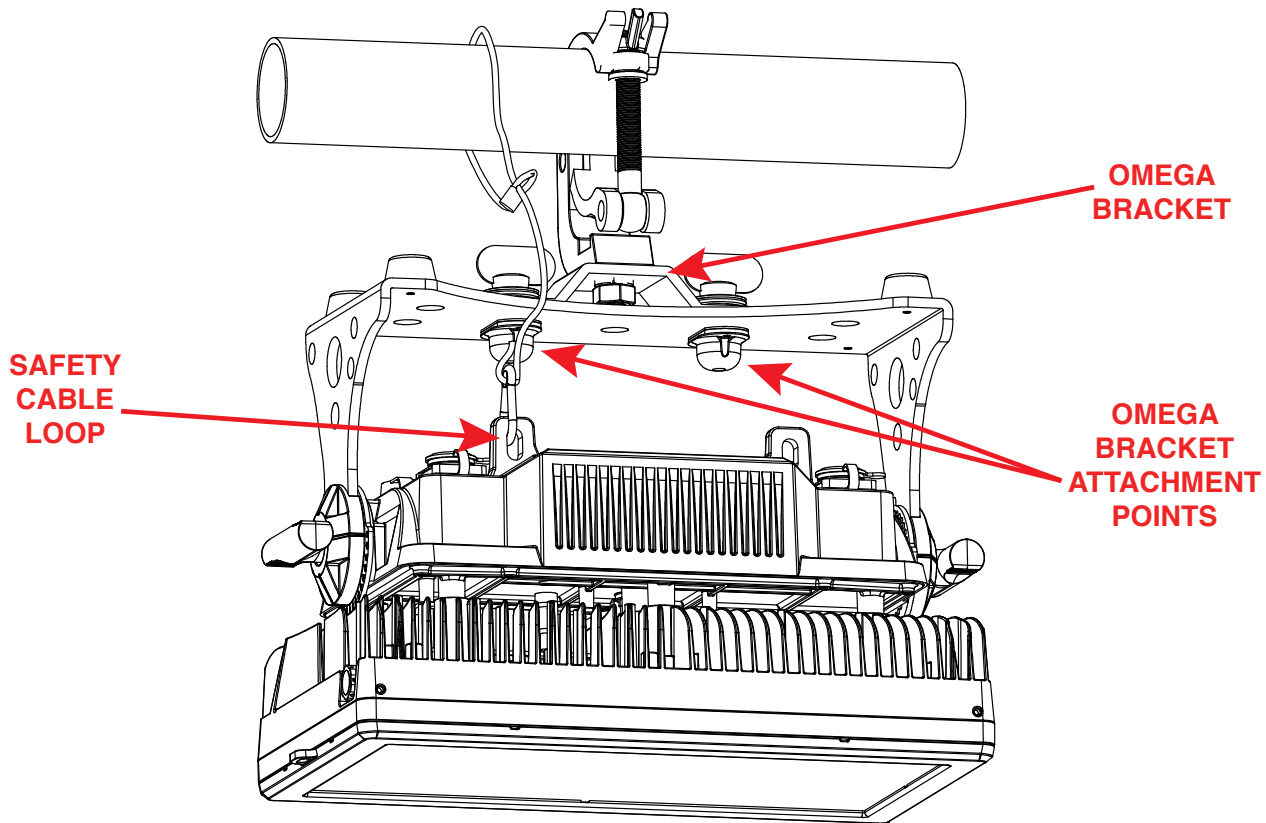

### SAFETY CABLE:



**ALWAYS ATTACH A SAFETY CABLE WHENEVER INSTALLING THIS FIXTURE IN A SUSPENDED ENVIRONMENT TO ENSURE THAT THE FIXTURE WILL NOT FALL IF THE CLAMP FAILS.**

# INSTALLATION

## STAND MOUNTING

This unit can also be installed atop a tripod stand. Simply secure the Omega bracket to the bottom face of the device, then insert the threaded bolt on the top of the tripod stand through the hole in the Omega bracket. Tighten the nut onto the threaded bolt to secure the mounted device in place.

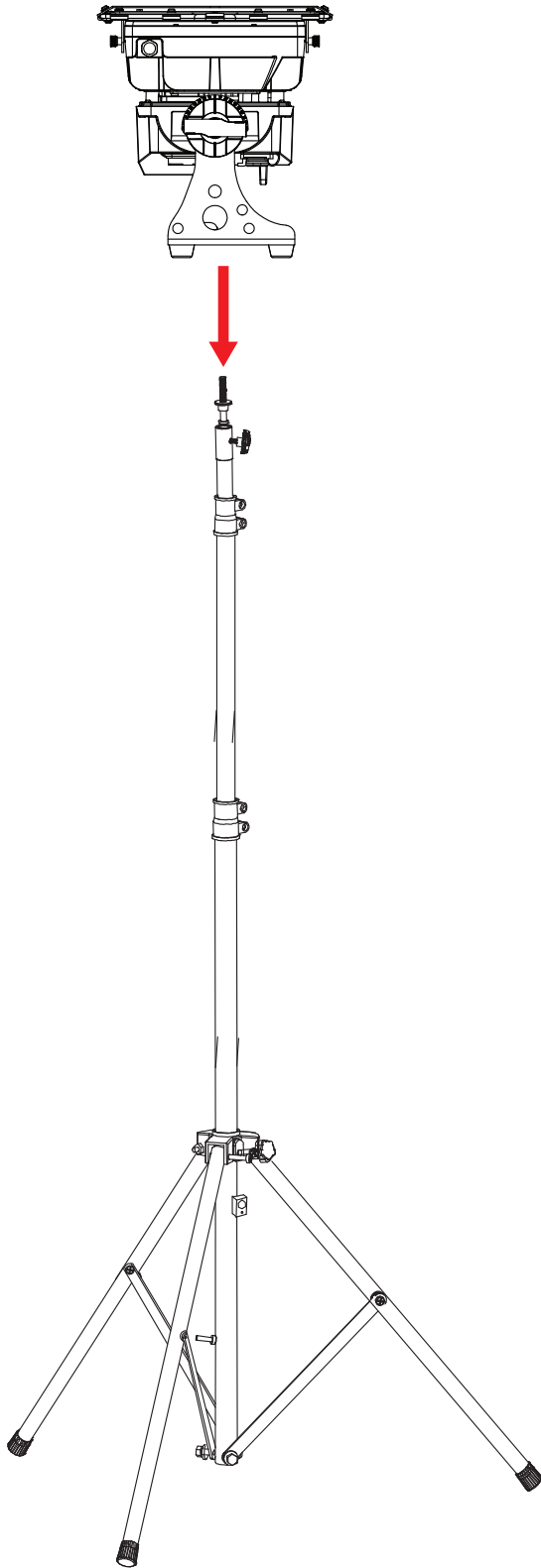

**CAUTION!**

**MAKE SURE THAT THE TRIPOD LEGS AND ALL TELESCOPING ELEMENTS OF THE TRIPOD STAND ARE LOCKED IN PLACE BEFORE INSTALLING THE DEVICE ATOP THE STAND!**

**POSITION THE TRIPOD STAND AND MOUNTED DEVICE ONLY ON FLAT, STABLE SURFACES!  
DEPLOY TRIPOD LEGS FULLY IN ORDER TO MAXIMIZE STABILITY!**

# INSTALLATION

## POTENTIAL INTERNAL FIXTURE DAMAGE FROM EXTERNAL SOURCES OF LIGHT BEAMS

External sources of light beams from direct sunlight, lighting and moving head fixtures, and lasers, which are focused directly towards the exterior housing and/or penetrate the front lens opening of ADJ lighting fixtures, can cause severe internal damage including burning of optics, dichroic color filters, glass and metal gobos, prisms, animation wheels, frost filters, iris, shutters, motors, belts, wiring, discharge lamps, and LEDs.

This issue is not specific only to ADJ lighting fixtures, but rather it is a common issue with lighting fixtures from all manufacturers. Although there is no true way to fully prevent this issue from happening, the guidelines below can reduce the risk of potential damage. Contact ADJ Service for more details.

**DO NOT EXPOSE THE FIXTURE AND/OR FRONT LENS OPENING TO LIGHT BEAMS FROM DIRECT SUNLIGHT, OTHER LIGHTING OR MOVING HEAD FIXTURES, AND LASERS DURING UNPACKING, INSTALLATION, USE, AND EXTENDED IDLE TIMES OUTDOORS. DO NOT FOCUS A LIGHT BEAM FROM ONE LIGHTING FIXTURE DIRECTLY TOWARDS ANOTHER.**

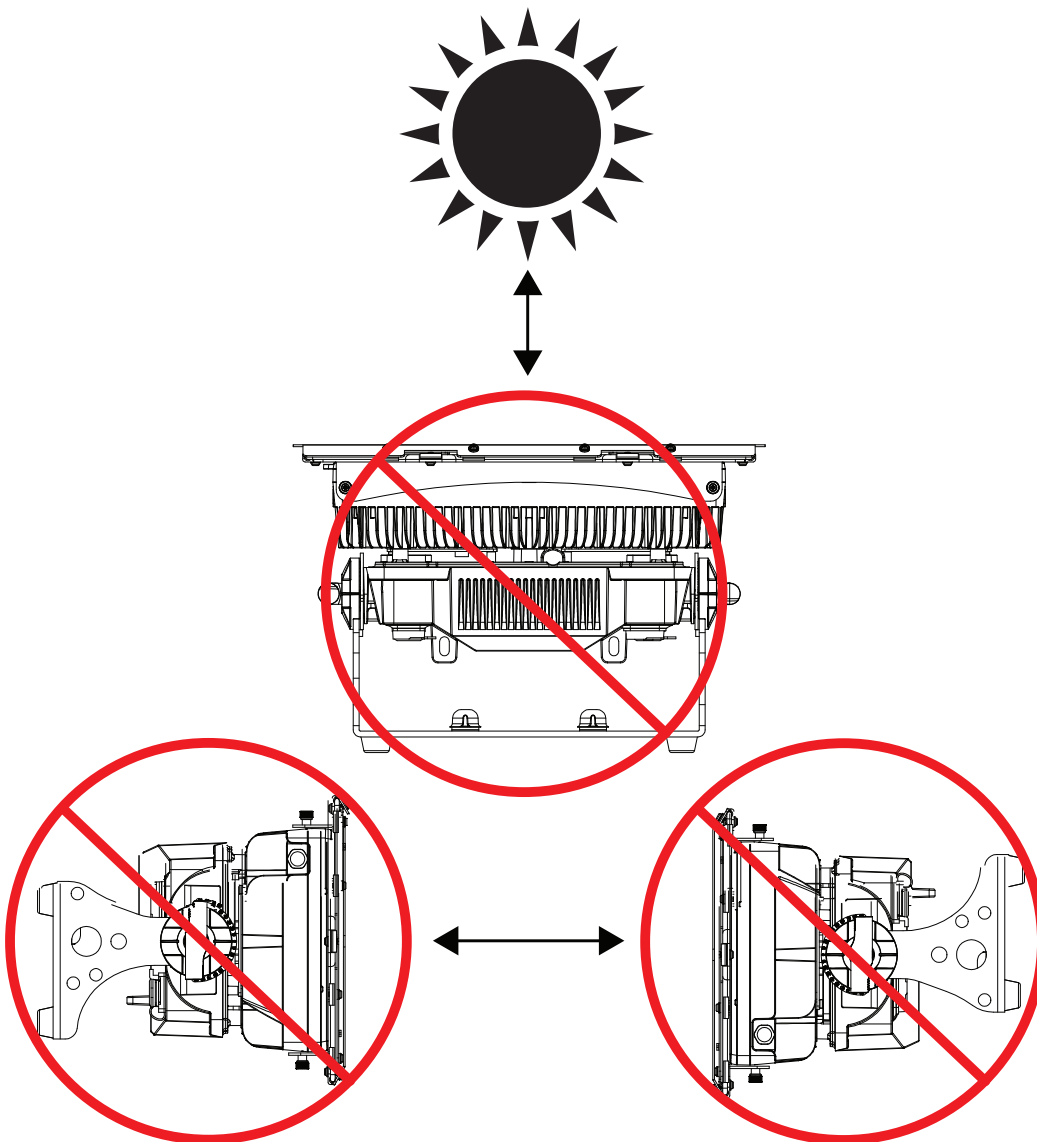

## INSTALLATION

**NOTICE:** The maximum ambient operational temperature for this lighting fixture is **113° F (45° C)**. Do not place this lighting fixture in an environment where the temperatures exceed this value. This will allow the fixture to run at its best and help prolong the fixture life.

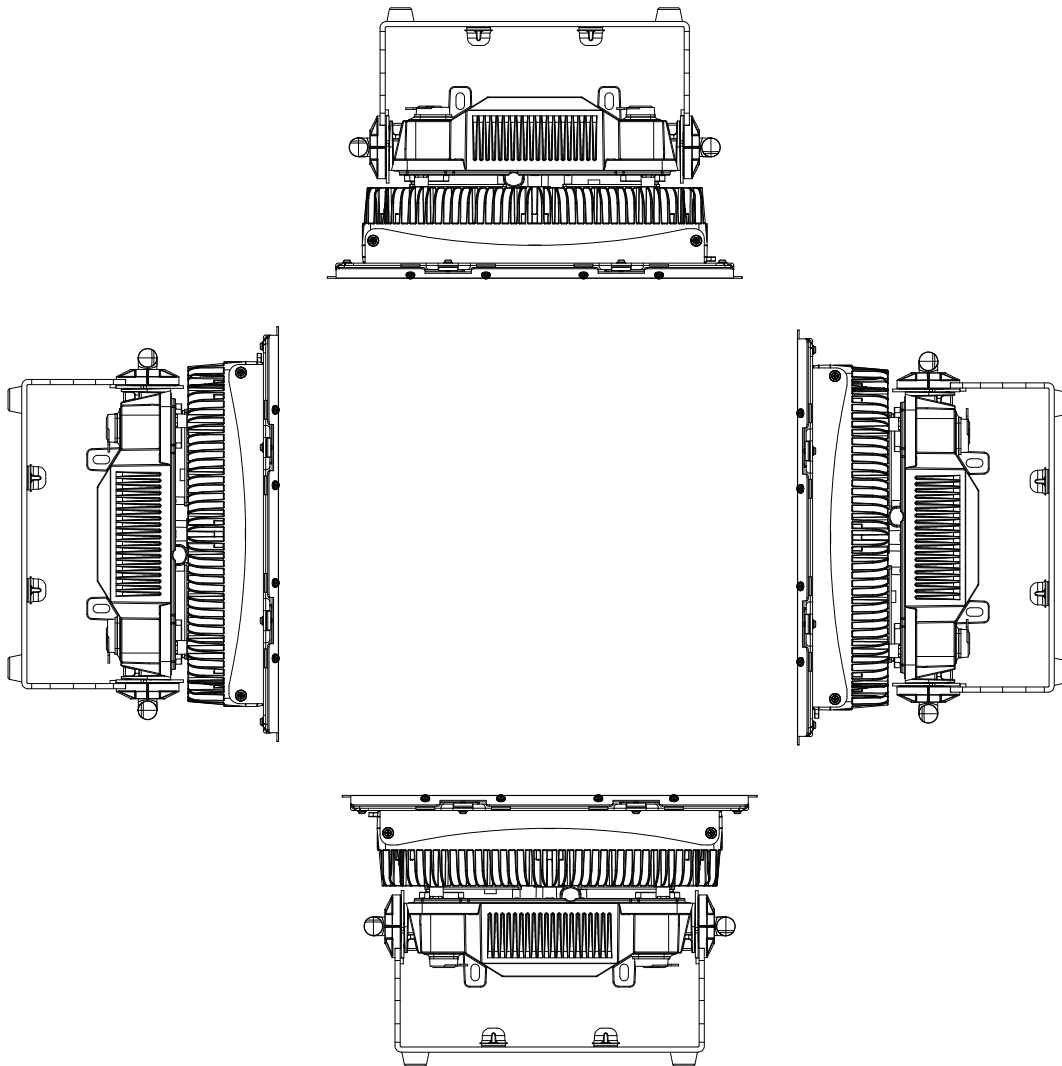

The unit is fully operational in three different mounting positions: hanging upside-down from the ceiling or trussing, sideways on trussing, or set on a flat level surface. Be sure this fixture is kept at least 12m (40ft) away from any flammable materials (decorations, etc). Always use and install a safety cable (not included) as a safety measure to prevent accidental damage and/or injury in the event the clamp fails. Never use the carrying handles for secondary attachment.

# INSTALLATION

## ACCESSORY INSTALLATION

Available accessories include a set of barndoors, as well as multiple frost filters.

1. To install the frost filter, slot the filter into place directly in front of the device's LED array.
2. Attach the frost filter frame in place on top of the frost filter to secure it in place.
3. If desired, the barndoors can then be installed atop the frost filter frame.
4. To secure the barndoors in place, align the screws on the barndoor mounting flanges with the threaded holes in the side of the fixture head, then tighten the screws. See the illustration below for reference.

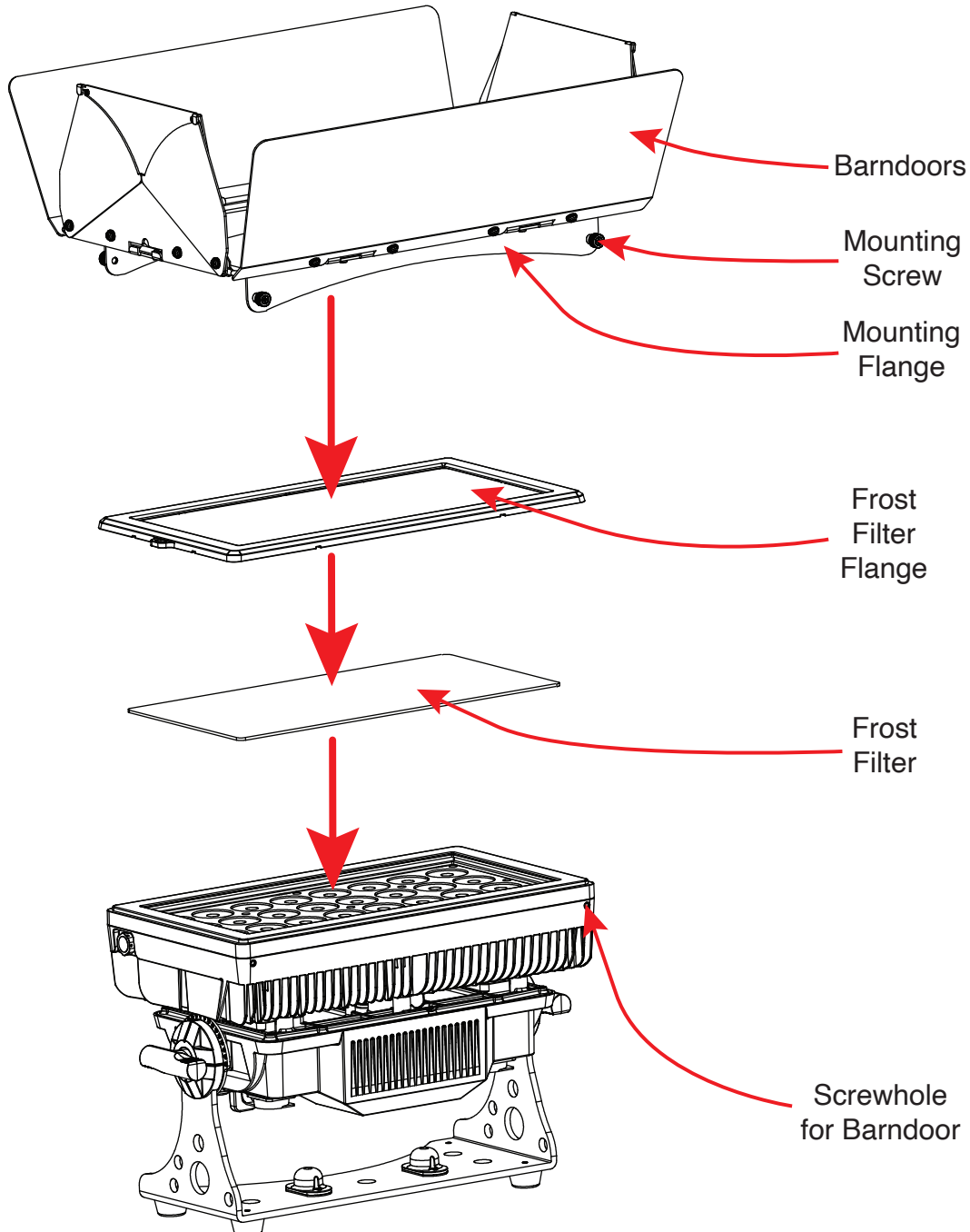

## WIRELESS SETUP

There are many factors that can affect and/or interrupt a wireless signal, including walls, glass, metal, objects, and people. Therefore, the following guidelines are recommended in order to maximize the chances of having a clear path for the wireless signal to reach the device:

- Install the device a minimum of 9.8 ft (3m) above audiences and/or ground level.
- Arrange the wireless antenna in an upright, vertical position.
- Position devices in direct line of sight of the transmitting controller.

Careful planning and testing of the selected installation location is critical to ensure optimum and reliable wireless operation.

9.8 ft (3m)  
Above Ground



## REMOTE DEVICE MANAGEMENT (RDM)

**NOTE: In order for RDM to work properly, RDM enabled equipment must be used throughout the entire system, including DMX data splitters and wireless systems.**

Remote Device Management (RDM) is a protocol that sits on top of the DMX512 data standard for lighting, allowing the DMX systems of the fixtures to be modified and monitored remotely. This protocol is ideal for instances in which a unit is installed in a location that is not easily accessible.

With RDM, the DMX512 system becomes bi-directional, allowing a compatible RDM enabled controller to send out a signal to devices on the wire, as well as allowing the fixture to respond (known as a *GET* command). The controller can then use its *SET* command to modify settings that would typically have to be changed or viewed directly via the unit's display screen, including the DMX Address, DMX Channel Mode, and Temperature Sensors.

### FIXTURE RDM INFORMATION:

RDM Code	Device ID	Device Model ID	Personality ID
0x1900	a0001	a	4ch (1); 7ch (2); 8ch (3); 13ch (4); 16ch (5); 32ch (6); 35ch (7); 41ch (8); 44ch (9); 64ch (a)

**Please be aware that not all RDM devices support all RDM features**, and therefore it is important to check beforehand to ensure that the equipment that you are considering includes all of the features that you require.

Proxied Device Count	Lamp On Mode
Sensor Definition	Device Power Cycles
Sensor Value	Display Invert
Device Model Description	Display Level
Manufacturer Label	Real Time Clock
Device Label	Power State
DMX Personality	Preset Playback
DMX Personality Description	Default Slot Value
Device Hours	Language
Comms Status	Language Capabilities
Status ID Description	Boot Software Version Label
Clear Status ID	Boot Software Version ID
Lamp Hours	Product Detail ID List
Lamp Strikes	Status Messages
Lamp State	



## CONTROL PANEL

The Encore LP32IP features a display screen with a 4-button control pad, which can be used to easily adjust any device settings.

Pressing the MODE button will cycle through the various Main Menu options. When the desired Main Menu option is displayed on the screen, press the SETUP button to enter the sub-menu, then use the UP and DOWN buttons to scroll through sub-menu options. In some cases, there will be a second sub-menu that can be navigated in the same way.

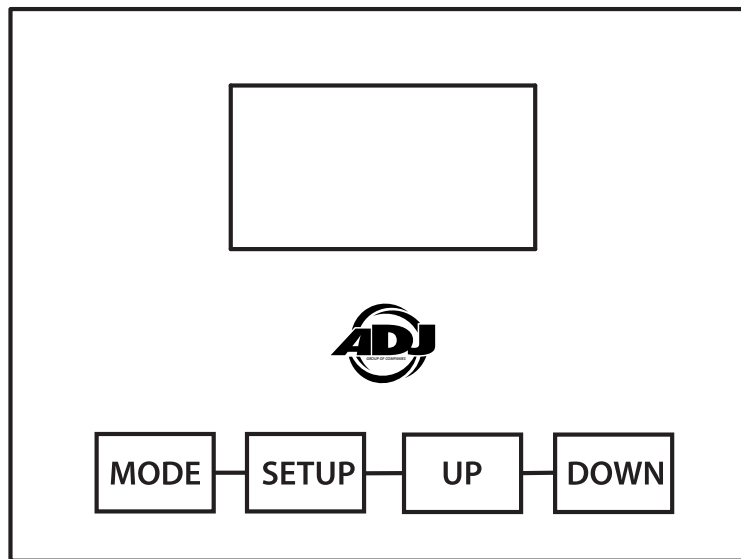

# SYSTEM MENU

DMX SET	Address	<b>001</b> - 512		Set DMX address	
	Ch. Mode	4ch		Select DMX channel mode	
		7ch			
		8ch			
		<b>13ch</b>			
		16ch			
		32ch			
		35ch			
		41ch			
		44ch			
		64ch			
	No DMX	<b>Hold</b>		Unit holds last channel values when DMX signal is lost	
		Blackout		Unit takes all channels to 0 when DMX signal is lost	
Manual		Unit defaults to Manual settings when DMX signal is lost			
Internal Programs		Unit defaults to Internal Program when DMX signal is lost			
PERSONALITY	Prim/Sec Mode	Primary / <b>Secondary</b>			
	Select Signal	DMX or Wifly		DMX has priority; green LED when Wifly connected and red LED when Wifly not connected	
		Wifly and DMX Out		DMX XLR output sends DMX signal out	
	Wifly Settings	Wifly Enable	<b>On</b> / Off		
		Set Wifly Channel	00 - 14		
	Fan Set	<b>Auto</b>			
		High			
Silent					
CONTINUED ON NEXT PAGE					

# SYSTEM MENU

<b>PERSONALITY (continued)</b>	Dim Mode	<b>Standard</b>			
		Stage			
		TV			
		Archi			
		Theatre			
		Stage 2			
		Dim Speed	0.1s - 10s		
	Dim Curve	Linear			
		<b>Square</b>			
		Inv. Squa			
		S Curve			
	LED Refresh	900, 1000, 1100, <b>1200</b> , 1300, 1400, 1500, 2500, 4000, 5000, 10k, 15k, 20k, 25k			
	Display	Save Dlay	1 - <b>10</b>		Screen saver delay
		Lock	Off, <b>30 sec</b> , 1min - 10min		Screen locks after pre-set period of inactivity
	Service	Passcode = 050	Calibrat	All Red 000 - 255	
				All Green 000 - 255	
				All Blue 000 - 255	
				All Lime 000 - 255	
				Red1 000 - 255	
				Green1 000 - 255	
Blue1 000 - 255					
Lime1 000 - 255					
...					
Red8 000 - 255					
Green8 000 - 255					
Blue8 000 - 255					
Lime8 000 - 255					

CONTINUED ON NEXT PAGE

# SYSTEM MENU

PERSONALITY (continued)	Service (continued)	Passcode = 050 (continued)	USB Powr	On / <i>Off</i>	
			S Update	Yes / <i>No</i>	Update software
			Restore	Yes / <i>No</i>	Restore to fac- tory default; passcode = 011
MANUAL	Red	000 - 255			
	Blue	000 - 255			
	Green	000 - 255			
	Lime	000 - 255			
	Clr Macro	00 - 64			Manually select color macro
	Clr Temp	000 - 255			Manually adjust color tempera- ture
	Strobe	000 - 255			
	Mastr Dim	000 - 255			Manually adjust master dimmer
	Auto Prog	000 - 255			Manually select automatic pro- gram
	Prog Spd	000 - 255			Manually adjust program speed
	Prog Fade	000 - 255			Manually adjust program fade
INT PROGS	Prog 0	Speed	000 - 255		
		Fade	000 - 255		
	Prog 1	Speed	000 - 255		
		Fade	000 - 255		
	...	...	...		
	Prog 13	Speed	000 - 255		
Fade		000 - 255			
INFO	Hours	Pwr On Hr 1	xxxxxx Hours		Lifetime total hours fixture has been powered on; cannot be reset
		Pwr On Hr 2	xxxxxx Hours		Hours fixture has been pow- ered on since last reset
		Pwr On Rst	Passcode = 050		Reset power on hours

CONTINUED ON NEXT PAGE

## SYSTEM MENU

<b>INFO (continued)</b>	Temp	xxx°	xxx F / xxx C		
		Max Temp 1	xxx F / xxx C		Max temp since last reset
		Max Temp 2	xxx F / xxx C		All time max temp; cannot be reset
		Temp Rst	Yes / No	Passcode = 050	Reset max temp
	Humidity	xxx%			Humidity in head
	Fan Info	Fan 1 RPM	xxxx		
		Fan 2 RPM	xxxx		
	DMX Value	Red			Displays current value for each DMX channel
		Green			
		...			
		Auto Prog			
	Soft Vers	x.xx			Display current software version

## DMX SET UP

**DMX-512:** DMX is short for Digital Multiplex. This is a universal protocol used as a form of communication between intelligent fixtures and controllers. A DMX controller sends DMX data instructions from the controller to the fixture. DMX data is sent as serial data that travels from fixture to fixture via the DATA “IN” and DATA “OUT” XLR terminals located on all DMX fixtures (most controllers only have a DATA “OUT” terminal).

**DMX Linking:** DMX is a language allowing all makes and models of different manufacturers to be linked together and operate from a single controller, as long as all fixtures and the controller are DMX compliant. To ensure proper DMX data transmission, try to use the shortest cable path possible when linking several DMX fixtures. The order in which fixtures are connected in a DMX line does not influence the DMX addressing. For example, a fixture assigned a DMX address of 1 may be placed anywhere in a DMX line: at the beginning, at the end, or anywhere in the middle. When a fixture is assigned a DMX address of 1, the DMX controller knows to send DATA assigned to address 1 to that unit, no matter where it is located in the DMX chain.

**Data Cable (DMX Cable) Requirements (For DMX Operation):** This unit can be controlled via DMX-512 protocol. The DMX address is set on the rear panel of the unit. Your unit and your DMX controller require a standard 5-pin XLR connector for data input and data output. We recommend Accu-Cable DMX cables. If you are making your own cables, be sure to use standard 110-120 Ohm shielded cable (This cable may be purchased at almost all pro lighting stores). Your cables should be made with a male XLR connector at one end and a female XLR connector at the other. Also remember that DMX cable must be daisy chained and cannot be split.

**Notice:** Be sure to follow the illustration below when making your own cables. Do not use the ground lug on the XLR connector. Do not connect the cable’s shield conductor to the ground lug or allow the shield conductor to come in contact with the XLR’s outer casing. Grounding the shield could cause a short circuit and erratic behavior.

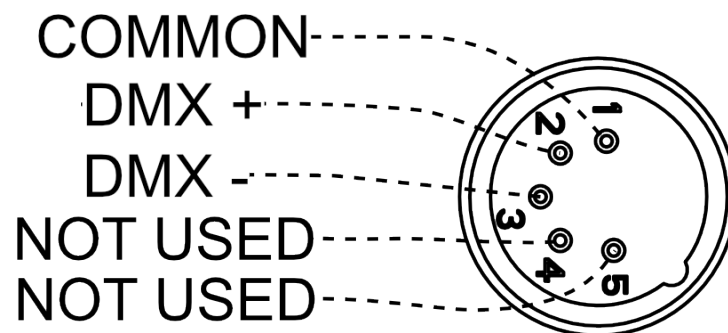

## DMX SET UP

**Special Note: Line Termination.** When longer runs of cable are used, you may need to use a terminator on the last unit to avoid erratic behavior. A terminator is a 110-120 ohm 1/4 watt resistor which is connected between pins 2 and 3 of a male XLR connector (DATA + and DATA -). This unit is inserted in the female XLR connector of the last unit in your daisy chain to terminate the line. Using a cable terminator (ADJ part number Z-DMX/T) will reduce the risk of erratic behavior.

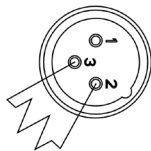
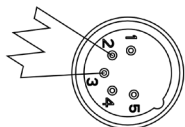

A DMX512 terminator reduces signal errors, avoiding most signal reflection interference. Connect PIN 2 (DMX-) and PIN 3 (DMX+) of the last fixture in series with a 120 Ohm, 1/4 W Resistor to terminate the DMX512.

### DMX ADDRESSING.

All fixtures should be given a DMX starting address when using a DMX controller, so the correct fixture responds to the correct control signal. This digital starting address is the channel number from which the fixture starts to “listen” to the digital control signal sent out from the DMX controller. The assignment of this starting DMX address is achieved by setting the correct DMX address on the digital control display on the fixture.

You can set the same starting address for all fixtures or a group of fixtures, or set different addresses for each individual fixture. Setting all fixtures to the same DMX address will cause all fixtures to react in the same way. In other words, changing the settings of one channel will affect all the fixtures simultaneously.

If you set each fixture to a different DMX address, each unit will start to “listen” to the channel number you have set, based on the quantity of DMX channels of each fixture. That means changing the settings of one channel will only affect the selected fixture.

For example, when this unit is operating in 4 channel mode, you should set the starting DMX address of the first unit to 1, the second unit to 5 (1 + 4), the third unit to 9 (1 + 4 + 4), and so on. See the chart below for more details.

CHANNEL MODE	UNIT 1 ADDRESS	UNIT 2 ADDRESS	UNIT 3 ADDRESS	UNIT 4 ADDRESS
4 Ch	1	5	9	13
7 Ch	1	8	15	22
8 Ch	1	9	17	25
13 Ch	1	14	27	40
16 Ch	1	17	33	49
32 Ch	1	33	65	97
35 Ch	1	36	71	106
41 Ch	1	42	83	124
44 Ch	1	45	89	133
64 Ch	1	65	129	193

# DMX TRAITS

CHANNEL										DMX VALUES	FUNCTION
4CH	7CH	8CH	13CH	16CH	32CH	35CH	41CH	44CH	64CH		
1	1	1	1	1						000 - 255	<b>All Red, 0% to 100%</b>
		2								000 - 255	<b>All Red Fine</b>
2	2	3	2	2						000 - 255	<b>All Green, 0% to 100%</b>
		4								000 - 255	<b>All Green Fine</b>
3	3	5	3	3						000 - 255	<b>All Blue, 0% to 100%</b>
		6								000 - 255	<b>All Blue Fine</b>
4	4	7	4	4						000 - 255	<b>All Lime, 0% to 100%</b>
		8								000 - 255	<b>All Lime Fine</b>
					1	1	1	1	1	000 - 255	<b>Red 1, 0% to 100%</b>
									2	000 - 255	<b>Red 1 Fine</b>
					2	2	2	2	3	000 - 255	<b>Green 1, 0% to 100%</b>
									4	000 - 255	<b>Green 1 Fine</b>
					3	3	3	3	5	000 - 255	<b>Blue 1, 0% to 100%</b>
									6	000 - 255	<b>Blue 1 Fine</b>
					4	4	4	4	7	000 - 255	<b>Lime 1, 0% to 100%</b>
									8	000 - 255	<b>Lime 1 Fine</b>
					5	5	5	5	9	000 - 255	<b>Red 2, 0% to 100%</b>
									10	000 - 255	<b>Red 2 Fine</b>
					6	6	6	6	11	000 - 255	<b>Green 2, 0% to 100%</b>
									12	000 - 255	<b>Green 2 Fine</b>
					7	7	7	7	13	000 - 255	<b>Blue 2, 0% to 100%</b>
									14	000 - 255	<b>Blue 2 Fine</b>
					8	8	8	8	15	000 - 255	<b>Lime 2, 0% to 100%</b>
									16	000 - 255	<b>Lime 2 Fine</b>
					9	9	9	9	17	000 - 255	<b>Red 3, 0% to 100%</b>
									18	000 - 255	<b>Red 3 Fine</b>
					10	10	10	10	19	000 - 255	<b>Green 3, 0% to 100%</b>
									20	000 - 255	<b>Green 3 Fine</b>
					11	11	11	11	21	000 - 255	<b>Blue 3, 0% to 100%</b>
									22	000 - 255	<b>Blue 3 Fine</b>
					12	12	12	12	23	000 - 255	<b>Lime 3, 0% to 100%</b>
									24	000 - 255	<b>Lime 3 Fine</b>
					13	13	13	13	25	000 - 255	<b>Red 4, 0% to 100%</b>
									26	000 - 255	<b>Red 4 Fine</b>
					14	14	14	14	27	000 - 255	<b>Green 4, 0% to 100%</b>
									28	000 - 255	<b>Green 4 Fine</b>
					15	15	15	15	29	000 - 255	<b>Blue 4, 0% to 100%</b>
									30	000 - 255	<b>Blue 4 Fine</b>
					16	16	16	16	31	000 - 255	<b>Lime 4, 0% to 100%</b>
									32	000 - 255	<b>Lime 4 Fine</b>
					17	17	17	17	33	000 - 255	<b>Red 5, 0% to 100%</b>

CONTINUED ON NEXT PAGE



# DMX TRAITS

CHANNEL										DMX VALUES	FUNCTION
4CH	7CH	8CH	13CH	16CH	32CH	35CH	41CH	44CH	64CH		
									34	000 - 255	<b>Red 5 Fine</b>
					18	18	18	18	35	000 - 255	<b>Green 5, 0% to 100%</b>
									36	000 - 255	<b>Green 5 Fine</b>
					19	19	19	19	37	000 - 255	<b>Blue 5, 0% to 100%</b>
									38	000 - 255	<b>Blue 5 Fine</b>
					20	20	20	20	39	000 - 255	<b>Lime 5, 0% to 100%</b>
									40	000 - 255	<b>Lime 5 Fine</b>
					21	21	21	21	41	000 - 255	<b>Red 6, 0% to 100%</b>
									42	000 - 255	<b>Red 6 Fine</b>
					22	22	22	22	43	000 - 255	<b>Green 6, 0% to 100%</b>
									44	000 - 255	<b>Green 6 Fine</b>
					23	23	23	23	45	000 - 255	<b>Blue 6, 0% to 100%</b>
									46	000 - 255	<b>Blue 6 Fine</b>
					24	24	24	24	47	000 - 255	<b>Lime 6, 0% to 100%</b>
									48	000 - 255	<b>Lime 6 Fine</b>
					25	25	25	25	49	000 - 255	<b>Red 7, 0% to 100%</b>
									50	000 - 255	<b>Red 7 Fine</b>
					26	26	26	26	51	000 - 255	<b>Green 7, 0% to 100%</b>
									52	000 - 255	<b>Green 7 Fine</b>
					27	27	27	27	53	000 - 255	<b>Blue 7, 0% to 100%</b>
									54	000 - 255	<b>Blue 7 Fine</b>
					28	28	28	28	55	000 - 255	<b>Lime 7, 0% to 100%</b>
									56	000 - 255	<b>Lime 7 Fine</b>
					29	29	29	29	57	000 - 255	<b>Red 8, 0% to 100%</b>
									58	000 - 255	<b>Red 8 Fine</b>
					30	30	30	30	59	000 - 255	<b>Green 8, 0% to 100%</b>
									60	000 - 255	<b>Green 8 Fine</b>
					31	31	31	31	61	000 - 255	<b>Blue 8, 0% to 100%</b>
									62	000 - 255	<b>Blue 8 Fine</b>
					32	32	32	32	63	000 - 255	<b>Lime 8, 0% to 100%</b>
									64	000 - 255	<b>Lime 8 Fine</b>
			5	5			33	33		000 - 255	<b>Color Macros, see Color Macros Chart section of this manual</b>
			6	6			34	34		000 - 255	<b>Color Temperature, 2700K to 7000K Linear</b>

CONTINUED ON NEXT PAGE

# DMX TRAITS

CHANNEL										DMX VALUES	FUNCTION
4CH	7CH	8CH	13CH	16CH	32CH	35CH	41CH	44CH	64CH		
			7	7			35	35			<b>Color Temperature Macros</b>
										000	Off
										001 - 042	2700K
										043 - 085	3200K
										086 - 128	4000K
										129 - 171	5600K
										172 - 214	6500K
										215 - 255	7000K
											<b>Shutter, Strobe</b>
										000 - 031	LEDs Off
										032 - 063	LEDs On
										064 - 095	Strobe Effect, slow to fast
	5		8	8		33	36	36		096 - 127	LEDs On
										128 - 159	Pulse Effect in Sequences
										160 - 191	LEDs On
										192 - 223	Random Strobe Effect, slow to fast
										224 - 255	LEDs On
	6		9	9		34	37	37		000 - 255	<b>Dimmer Intensity</b> , 0% to 100%
	7		10	10		35	38	38		000 - 255	<b>Dimmer Fine</b>
											<b>Auto Programs</b>
										000 - 010	Off
										011 - 026	Auto Program 1
										027 - 043	Auto Program 2
										044 - 060	Auto Program 3
										061 - 076	Auto Program 4
										077 - 093	Auto Program 5
				11				39		094 - 110	Auto Program 6
										111 - 126	Auto Program 7
										127 - 143	Auto Program 8
										144 - 160	Auto Program 9
										161 - 176	Auto Program 10
										177 - 193	Auto Program 11
										194 - 210	Auto Program 12
										211 - 226	Auto Program 13
										227 - 255	No Function
				12				40		000 - 255	<b>Auto Programs Speed</b> , slow to fast
				13				41		000 - 255	<b>Auto Programs Fade</b> , least to most

CONTINUED ON NEXT PAGE

# DMX TRAITS

CHANNEL										DMX VALUES	FUNCTION	
4CH	7CH	8CH	13CH	16CH	32CH	35CH	41CH	44CH	64CH			
												<b>Dim Mode</b>
											000 - 020	Default to Unit Setting
											021 - 040	Standard
											041 - 060	Stage
											061 - 080	TV
											081 - 100	Architectural
											101 - 120	Theatre
											121 - 140	Stage 2
												<b>Dim Speed</b>
											141	0.1s
											142	0.2s
											143	0.3s
											144	0.4s
											145	0.5s
			11	14			39	42			146	0.6s
											147	0.7s
											148	0.8s
											149	0.9s
											150	1.0s
											151	1.5s
											152	2.0s
											153	3.0s
											154	4.0s
											155	5.0s
											156	6.0s
											157	7.0s
											158	8.0s
											159	9.0s
											160	10.0s
											161 - 255	Default to Unit Setting
												<b>Dim Curves</b>
											000 - 020	Linear
											021 - 040	Square
											041 - 060	Inv Squa
											061 - 080	S Curve
											081 - 255	No Function
												<b>Refresh Rates</b>
											000 - 015	Default to Unit Setting
											016 - 030	900 Hz
											031 - 045	1000 Hz
											046 - 060	1100 Hz
			12	15			40	43				
			13	16			41	44				

CONTINUED ON NEXT PAGE

# DMX TRAITS

CHANNEL										DMX VALUES	FUNCTION
4CH	7CH	8CH	13CH	16CH	32CH	35CH	41CH	44CH	64CH		
			13	16			41	44			<i>Refresh Rates (continued)</i>
										061 - 075	1200 Hz
										076 - 090	1300 Hz
										091 - 105	1400 Hz
										106 - 120	1500 Hz
										121 - 135	2500 Hz
										136 - 150	4000 Hz
										151 - 165	5000 Hz
										166 - 180	10000 Hz
										181 - 195	15000 Hz
										196 - 210	20000 Hz
										211 - 225	25000 Hz
										226 - 255	No Function

# PIXEL ZONES

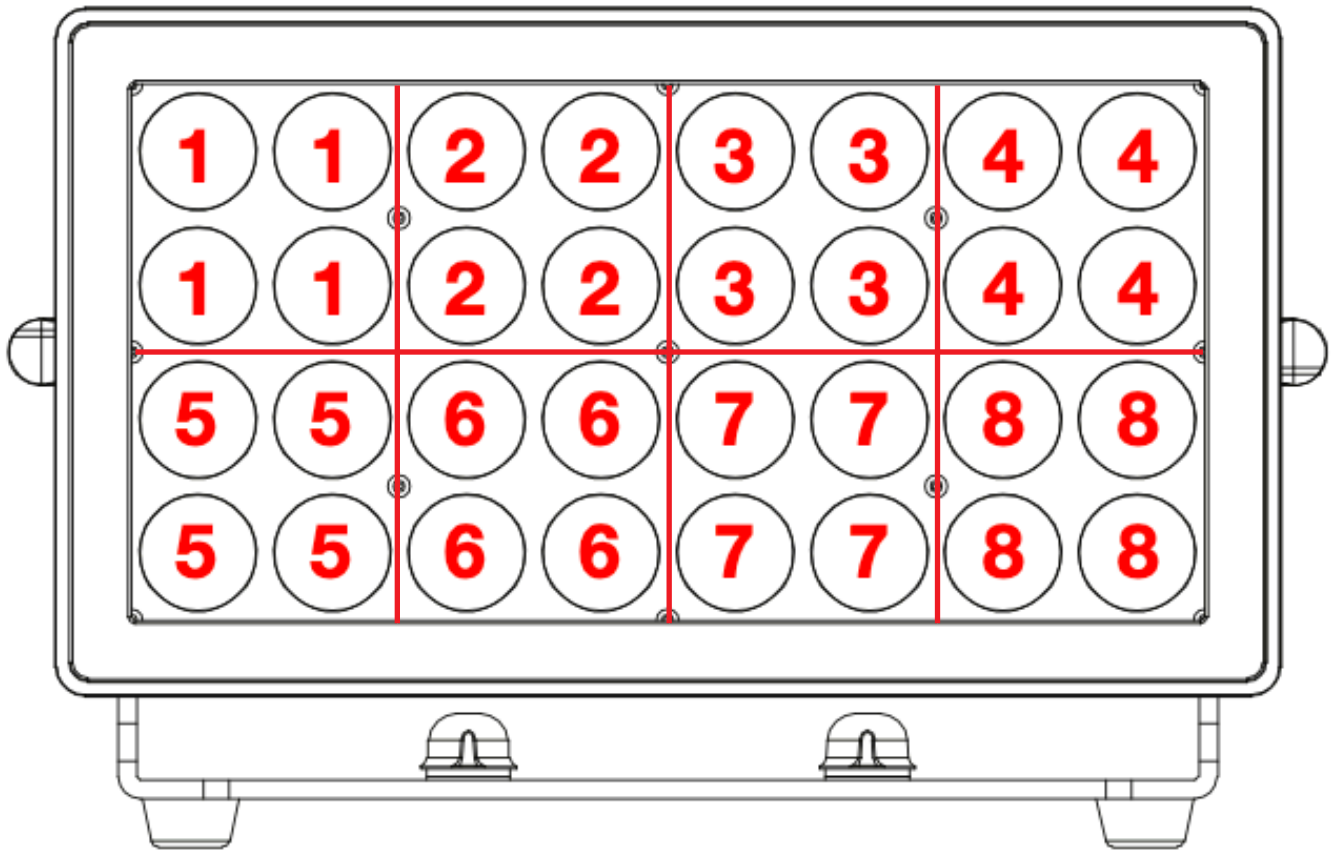

## COLOR MACROS CHART

COLOR MACRO NUMBER	DMX VALUES	RED	GREEN	BLUE	LIME
Off	000	0	0	0	0
1	001 - 004	80	255	234	80
2	005 - 008	80	255	164	80
3	009 - 012	77	255	112	77
4	013 - 016	117	255	83	83
5	017 - 020	160	255	77	77
6	021 - 024	223	255	83	83
7	025 - 028	255	243	77	77
8	029 - 032	255	200	74	74
9	033 - 036	255	166	77	77
10	037 - 040	255	125	74	74
11	041 - 044	255	97	77	74
12	045 - 048	255	71	77	71
13	049 - 052	255	83	134	83
14	053 - 056	255	93	182	93
15	057 - 060	255	96	236	96
16	061 - 064	238	93	255	93
17	065 - 068	196	87	255	87
18	069 - 072	150	90	255	90
19	073 - 076	100	77	255	77
20	077 - 080	77	100	255	77
21	081 - 084	67	148	255	67
22	085 - 088	77	195	255	77
23	089 - 092	77	234	255	77
24	093 - 096	158	255	144	144
25	097 - 100	255	251	153	153
26	101 - 104	255	175	147	147
27	105 - 108	255	138	186	138
28	109 - 112	255	147	251	147
29	113 - 116	151	138	255	138
30	117 - 120	99	0	255	100
31	121 - 124	138	169	255	138
32	125 - 128	255	255	255	255
33	129 - 132	255	206	143	0
34	133 - 136	254	177	153	0
35	137 - 140	254	192	138	0
CONTINUED ON NEXT PAGE					

## COLOR MACROS CHART

COLOR MACRO NUMBER	DMX VALUES	RED	GREEN	BLUE	LIME
36	141 - 144	254	165	98	0
37	145 - 148	254	121	0	0
38	149 - 152	176	17	0	0
39	153 - 156	96	0	11	0
40	157 - 160	234	139	171	0
41	161 - 164	224	5	97	0
42	165 - 168	175	77	173	0
43	169 - 172	119	130	199	0
44	173 - 176	147	164	212	0
45	177 - 180	88	2	163	0
46	181 - 184	0	38	86	0
47	185 - 188	0	142	208	0
48	189 - 192	52	148	209	0
49	193 - 196	1	134	201	0
50	197 - 200	0	145	212	0
51	201 - 204	0	121	192	0
52	205 - 208	0	129	184	0
53	209 - 212	0	83	115	0
54	213 - 216	0	97	166	0
55	217 - 220	1	100	167	0
56	221 - 224	0	40	86	0
57	225 - 228	209	219	182	0
58	229 - 232	42	165	85	0
59	233 - 236	0	46	35	0
60	237 - 240	8	107	222	0
61	241 - 244	255	0	0	0
62	245 - 248	0	255	0	0
63	249 - 252	0	0	255	0
64	253 - 255	0	0	0	255

## DIM SPEEDS

<b>DMX VALUES</b>	<b>DELAY TIME</b>
141	0.1 sec
142	0.2 sec
143	0.3 sec
144	0.4 sec
145	0.5 sec
146	0.6 sec
147	0.7 sec
148	0.8 sec
149	0.9 sec
150	1.0 sec
151	1.5 sec
152	2.0 sec
153	3.0 sec
154	4.0 sec
155	5.0 sec
156	6.0 sec
157	7.0 sec
158	8.0 sec
159	9.0 sec
160	10.0 sec



# DIM MODES

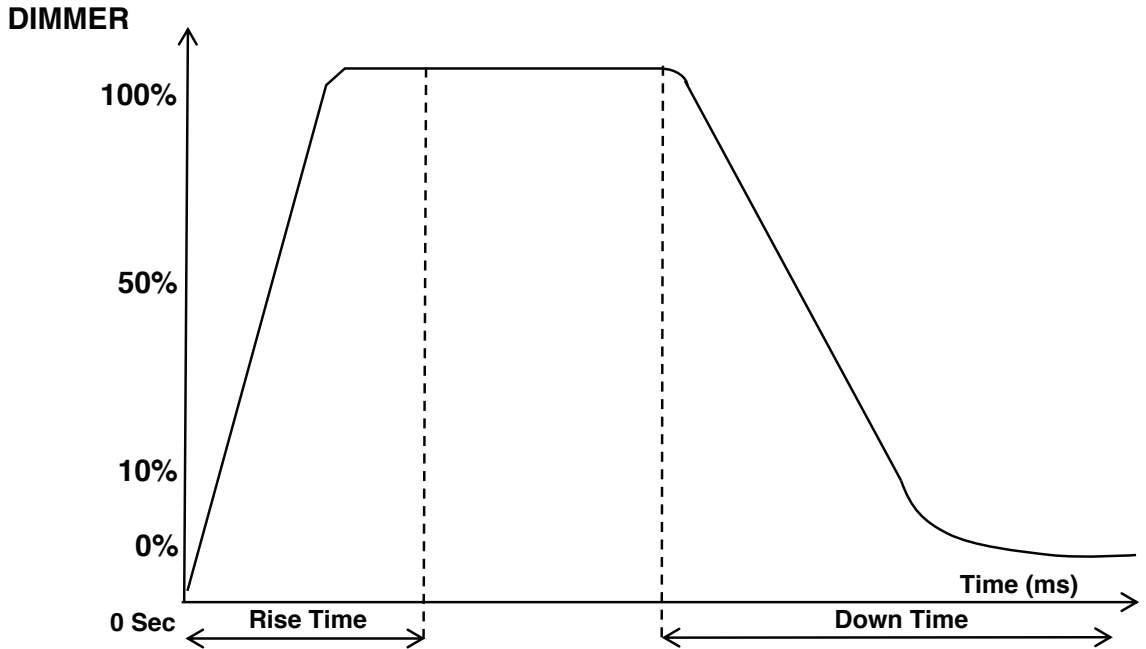

Dimming Curve Ramp Effect	0 sec Fade Time		1 sec Fade Time	
	Rise Time (ms)	Down Time (ms)	Rise Time (ms)	Down Time (ms)
Standard (default)	0	0	0	0
Stage	780	1100	1540	1660
TV	1180	1520	1860	1940
Architectural	1380	1730	2040	2120
Theatre	1580	1940	2230	2280
Stage 2	0	1100	0	1660

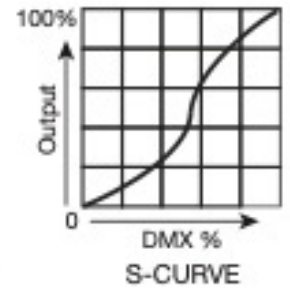
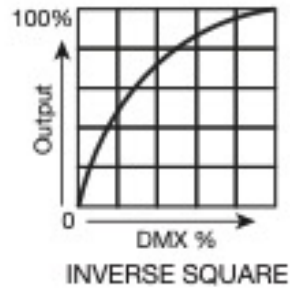
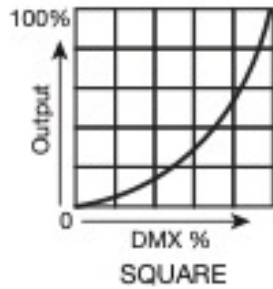
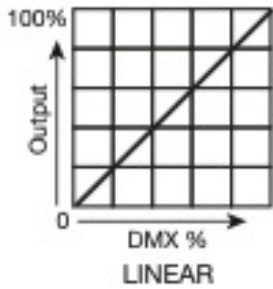

## **PRIMARY-SECONDARY SET UP**

This function allows you to link units together to run in a Primary-Secondary set-up, in which one unit will act as the controlling unit and the others will react to the controlling unit's built-in programs. Any unit can be configured to act as a Primary or as a Secondary, but only one unit in a given system can be programmed to act as the Primary.

### ***Primary-Secondary Connections and Settings:***

1. Daisy chain your units via the XLR connectors on the rear panels of each unit. Use standard XLR data cables to link your units together. Remember that the male XLR connector is the input and the female XLR connector is the output. The first unit in the chain (primary) will use the female XLR connector only. The last unit in the chain will use the male XLR connector only.
2. Use the display screen and control panel to navigate to Personality > PrimSec Mode. Select this sub-menu using the ENTER button, and use the arrows to toggle between "Primary" and "Secondary". Press ENTER to confirm your selection.
3. Repeat Step 2 for each unit in the system. Make sure that only one unit is designated as the Primary, while all other units are designated as Secondaries.
4. The secondary units will now follow the behavior of the primary unit.

## **MULTI UNIT POWER LINKING**

This feature allows you to connect the fixtures to one another using the power cable input and output sockets.

**The maximum number of units that can be linked in this manner is as follows:**

- 2 units when running on 110V power.
- 7 units when running on 240V power.

***DO NOT EXCEED THIS MAXIMUM NUMBER WHEN POWER LINKING UNITS!***

All linked units must be of the same make and model type. Do not mix and match units!

## MAINTENANCE GUIDELINES



**DISCONNECT POWER BEFORE PERFORMING ANY MAINTENANCE!**

### CLEANING

Frequent cleaning is recommended to ensure proper function, optimized light output, and an extended life. The frequency of cleaning depends on the environment in which the fixture operates: damp, smoky, or particularly dirty environments can cause greater accumulation of dirt on the fixture's optics. Clean the external lens surface regularly with a soft cloth to avoid dirt/debris accumulation.

**NEVER** use alcohol, solvents, or ammonia-based cleaners.

### MAINTENANCE

Regular inspections are recommended to ensure proper function and extended life. There are no user serviceable parts inside this fixture. Please refer all other service issues to an authorized ADJ service technician. Should you need any spare parts, please order genuine parts from your local ADJ dealer.

Please refer to the following points during routine inspections:

- A. A detailed electrical check by an approved electrical engineer every three months, to make sure the circuit contacts are in good condition and prevent overheating.
- B. Be sure all screws and fasteners are securely tightened at all times. Loose screws may fall out during normal operation, resulting in damage or injury as larger parts could fall.
- C. Check for any deformations on the housing, color lenses, rigging hardware, and rigging points (ceiling, suspension, trussing). Deformations in the housing could allow for dust to enter into the fixture. Damaged rigging points or unsecured rigging could cause the fixture to fall and seriously injure a person(s).
- D. Electric power supply cables must not show any damage, material fatigue, or sediments.

**NEVER** remove the ground prong from the power cable.

### SOFTWARE UPDATES

Please contact ADJ service for assistance with updating your device's software.

# DIMENSIONAL DRAWINGS

## FIXTURE ONLY

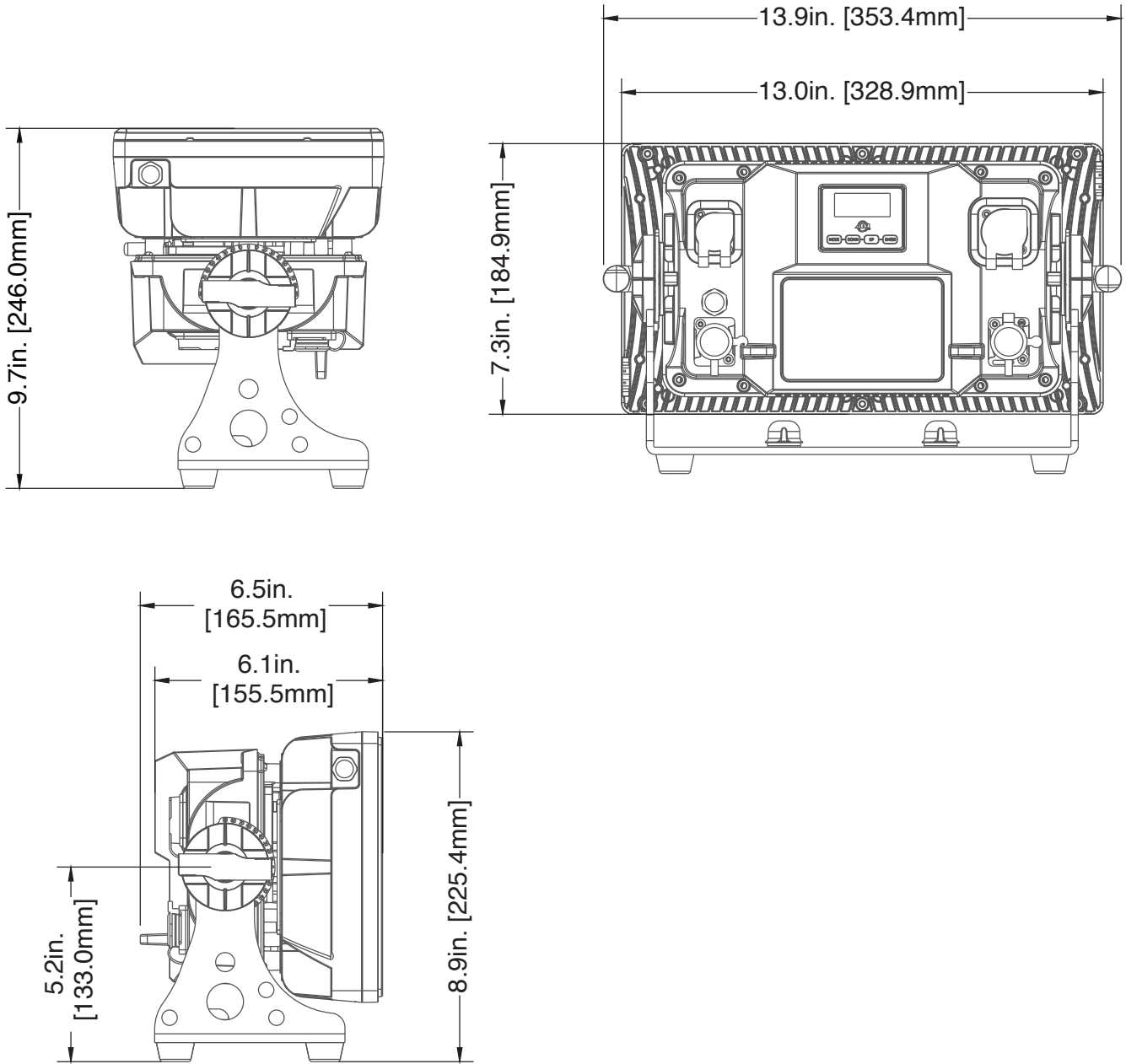

Drawings not shown to scale.

# DIMENSIONAL DRAWINGS

## BARNDOOR INSTALLED

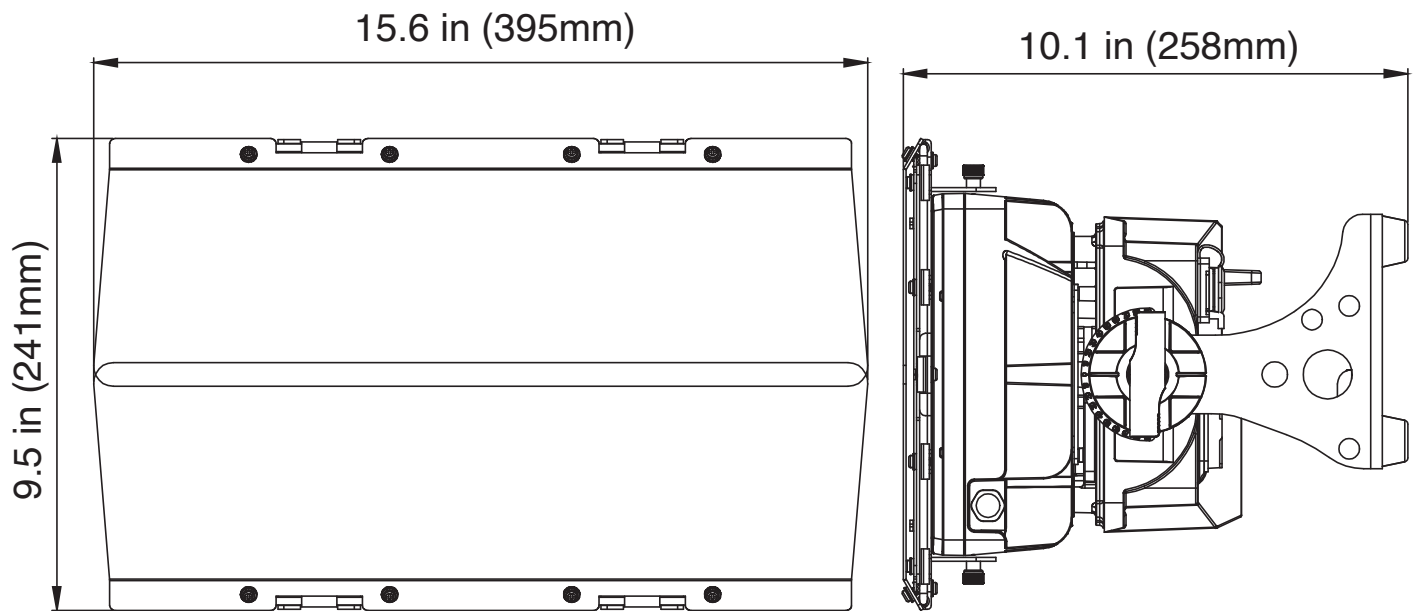

Drawings not shown to scale.

# SPECIFICATIONS

## Light Source:

- LED: 32 x 20W RGBL LED's (50,000 hr.)
- Beam Angle: 11°, 25° with Frost Filter
- Field Angle: 23.7°, 47° with Frost Filter
- LUX: 157,491 @ 1M, 6,300 @ 5M (Full On); 28,363 @ 1M, 1,135 @ 5M (Full On) with Frost Filter

## Features:

- IP65 rated – protects from dust, sand, moisture, water
- All metal construction with black housing
- Includes heavy duty floor / mounting bracket with omega clamp receivers
- Sure-lock locking bracket system (securely locks every 10°)
- Includes magnetic removable filter frame to add a diffusion filter
- Flicker free for film and broadcast
- Linear variable white temperature control (2700K - 7000K)
- Built-in antenna for WiFLY EXR Wireless DMX

## Construction:

- Display: OLED display with function buttons
- Data In/Out: IP65 Locking 5-pin XLR, DMX In/Out (with rubber protective covers over connections)
- Power In/Out: IP65 Locking Power In/Out (with rubber protective covers over connections)
- All Metal Heavy-Duty Housing: Built To Last In Outdoor or Touring Applications

## Control:

- WiFLY EXR Wireless DMX built-in (2500 ft. / 700M line of sight)
- Multiple DMX channel modes
- 8 individually controlled sections with Pixel Zone Control
- 0-100% Dimming + smooth 16-bit Dimming
- 6 Dim Modes
- 4 Dim Curves
- User settable Dim Speed control
- Control Mode: DMX512, RDM (Remote Device Management)
- LED Refresh Rate: 900Hz - 25Khz
- With Wired Digital Communication Network
- Selectable Fan Modes: Silent, Auto or High

## Electrical:

- Power voltage: AC100-240V, 47/63Hz (Multi-voltage)
- Daisy chain up to 2 fixtures max (@ 120V); 6 fixtures max (@ 240V)
- Power consumption: 334W Max

## Dimensions & Weight:

- Dimensions: 13.9" x 9.7" x 6.5" / 353.4 x 246.0 x 165.5mm
- Weight: 24.25 lbs. / 11 kg.

## INCLUDED ACCESSORIES:

- 25° frost filter with metal frame
- Outdoor Locking Power Cord

## OPTIONAL ACCESSORIES:

- ELP32L20: 20° frost filter + metal frame for Encore LP32IP
- ELP32L60: 60° frost filter + metal frame for Encore LP32IP
- ELP32L100: 100° frost filter + metal frame for Encore LP32IP
- Barn Door: BAR032

## Approvals / Rating:

CE Certified



*Please Note: Specifications and improvements in the design of this unit and this manual are subject to change without any prior written notice.*



