



ENCORE PROFILE PRO WW

User Instructions

©2024 ADJ Products, LLC all rights reserved. Information, specifications, diagrams, images, and instructions herein are subject to change without notice. ADJ Products, LLC logo and identifying product names and numbers herein are trademarks of ADJ Products, LLC. Copyright protection claimed includes all forms and matters of copyrightable materials and information now allowed by statutory or judicial law or hereinafter granted. Product names used in this document may be trademarks or registered trademarks of their respective companies and are hereby acknowledged. All non-ADJ Products, LLC brands and product names are trademarks or registered trademarks of their respective companies.

ADJ Products, LLC and all affiliated companies hereby disclaim any and all liabilities for property, equipment, building, and electrical damages, injuries to any persons, and direct or indirect economic loss associated with the use or reliance of any information contained within this document, and/or as a result of the improper, unsafe, insufficient and negligent assembly, installation, rigging, and operation of this product.

ADJ PRODUCTS LLC World Headquarters

6122 S. Eastern Ave. | Los Angeles, CA 90040 USA

Tel: 800-322-6337 | Fax: 323-582-2941 | www.adj.com | lsupport@adj.com

ADJ Supply Europe B.V.

Junostraat 2 | 6468 EW Kerkrade | Netherlands

Tel: +31 45 546 85 00 | Fax: +31 45 546 85 99 | www.americandj.eu | service@americandj.eu

Europe Energy Saving Notice

Energy Saving Matters (EuP 2009/125/EC)

Saving electric energy is a key to help protecting the environment. Please turn off all electrical products when they are not in use. To avoid power consumption in idle mode, disconnect all electrical equipment from power when not in use. Thank you!

DOCUMENT VERSION



Due to additional product features and/or enhancements, an updated version of this document may be available online.

Please check www.adj.com for the latest revision/update of this manual before beginning installation and/or programming.

Date	Document Version	Software Version >	DMX Channel Mode	Notes
07/23/2020	1.0	1.01	2/3/6	Initial Release
08/09/2021	1.5	N/C	N/C	Updated Specifications
10/12/2021	2.0	1.03	N/C	Updated System Menu, DMX Traits
02/06/2023	2.5	N/C	N/C	Added Accessory Installation and Optional Accessories; updated Installation
06/06/2023	3.0	N/C	N/C	Updated specifications
02/13/2024	3.5	N/C	N/C	Accessory Update
05/16/2024	4.0	1.07	1/2/3/6	Added 1 Channel Mode

CONTENTS

General Information	4
Limited Warranty (USA Only)	5
Safety Guidelines	6
Overview	8
Installation	9
Accessory Installation	11
System Menu	13
Multiple Unit Power Linking Dimmer Mode Chart	16
DMX Setup DMX Addressing	17
DMX Traits: Channel Functions & Values	18
Specifications	20
Optional Accessories	21
Dimensional Drawings	22
Dimensional Drawings - Optional Lens Kits	23
Troubleshooting Cleaning Maintenance	26
FCC Statement	27

GENERAL INFORMATION

INTRODUCTION

Please read and understand all instructions in this manual carefully and thoroughly before attempting to operate these products. These instructions contain important safety and use information.

UNPACKING

The products in this kit have been thoroughly tested and have been shipped in perfect operating condition. Carefully check the shipping carton for damage that may have occurred during shipping. If the carton appears to be damaged, carefully inspect each unit included for damage and be sure all accessories necessary to operate the units have arrived intact. In the event damage has been found or parts are missing, please contact our customer support team for further instructions. Please do not return this kit to your dealer without first contacting customer support at the number listed below. Please do not discard the shipping carton in the trash. Please recycle whenever possible.

WARRANTY RETURNS

All returned service items whether under warranty or not, must be freight pre-paid and accompany a return authorization (R.A.) number. The R.A. number must be clearly written on the outside of the return package. A brief description of the problem as well as the R.A. number must also be written down on a piece of paper and included in the shipping container. If the unit is under warranty, you must provide a copy of your proof of purchase invoice. Items returned without a R.A. number clearly marked on the outside of the package will be refused and returned at customer's expense. You may obtain a R.A. number by contacting customer support.

LIMITED WARRANTY (USA ONLY)

- A. ADJ Products, LLC hereby warrants, to the original purchaser, ADJ Products, LLC products to be free of manufacturing defects in material and workmanship for a prescribed period from the date of purchase (see specific warranty period on reverse). This warranty shall be valid only if the product is purchased within the United States of America, including possessions and territories. It is the owner's responsibility to establish the date and place of purchase by acceptable evidence, at the time service is sought.
- B. For warranty service, you must obtain a Return Authorization number (RA#) before sending back the product-please contact ADJ Products, LLC Service Department at 800-322-6337. Send the product only to the ADJ Products, LLC factory. All shipping charges must be pre-paid. If the requested repairs or service (including parts replacement) are within the terms of this warranty, ADJ Products, LLC will pay return shipping charges only to a designated point within the United States. If the entire instrument is sent, it must be shipped in its original package. No accessories should be shipped with the product. If any accessories are shipped with the product, ADJ Products, LLC shall have no liability whatsoever for loss of or damage to any such accessories, or for the safe return thereof.
- C. This warranty is void if the serial number has been altered or removed; if the product is modified in any manner which ADJ Products, LLC concludes, after inspection, affects the reliability of the product, if the product has been repaired or service by anyone other than ADJ Products, LLC factory unless prior written authorization was issued to purchaser by ADJ Products, LLC; if the product is damaged because not properly maintained as set forth in the instruction manual.
- D. This is not a service contract, and this warranty does not include maintenance, cleaning or periodic check up. During the period specified above, ADJ Products, LLC will replace defective parts at its expense with new or refurbished parts, and will absorb all expenses for warranty service and repair labor by reason of defects in material or workmanship. The sole responsibility of ADJ Products, LLC under this warranty shall be limited to the repair of the product, or replacement thereof, including parts, at the sole discretion of ADJ Products, LLC. All products covered by this warranty were manufactured after August 15, 2012, and bear identifying marks to that effect.
- E. ADJ Products, LLC reserves the right to make changes in design and/or improvements upon its products without any obligation to include these changes in any products theretofore manufactured.
- F. No warranty, whether expressed or implied, is given or made with respect to any accessory supplied with products described above. Except to the extent prohibited by applicable law, all implied warranties made by ADJ Products, LLC in connection with this product, including warranties of merchantability or fitness, are limited in duration to the warranty period set forth above. And no warranties, whether expressed or implied, including warranties of merchantability or fitness, shall apply to this product after said period has expired. The consumer's and/or Dealer's sole remedy shall be such repair or replacement as is expressly provided above; and under no circumstances shall ADJ Products, LLC be liable for any loss or damage, direct or consequential, arising out of the use of, or inability to use, this product.
- G. This warranty is the only written warranty applicable to ADJ Products, LLC Products and supersedes all prior warranties and written descriptions of warranty terms and conditions heretofore published.

LIMITED WARRANTY PERIODS

- **Non L.E.D. Lighting Products = 1-year (365 days) Limited Warranty** (Such as: Special Effect Lighting, Intelligent Lighting, UV lighting, Strobes, Fog Machines, Bubble Machines, Mirror Balls, Par Cans, Trussing, Lighting Stands etc. excluding LED and lamps)
- **Laser Products = 1 Year (365 Days) Limited Warranty** (excludes laser diodes which have 6 month limited warranty)
- **L.E.D. Products = 2-year (730 days) Limited Warranty** (excluding batteries which have a 180 day limited warranty)
Note: 2 Year Warranty only applies to purchases within the United States.
- **StarTec Series = 1 Year Limited Warranty** (excluding batteries which have a 180 day limited warranty)
- **ADJ DMX Controllers = 2 Year (730 Days) Limited Warranty**

SAFETY GUIDELINES

THIS FIXTURE IS COMPOSED OF SOPHISTICATED ELECTRONIC COMPONENTS. TO GUARANTEE SMOOTH OPERATION, IT IS IMPORTANT TO FOLLOW ALL INSTRUCTIONS AND GUIDELINES IN THIS MANUAL. ADJ PRODUCTS, LLC IS NOT RESPONSIBLE FOR INJURY AND/OR DAMAGES RESULTING FROM THE MISUSE OF THIS FIXTURE DUE TO THE DISREGARD OF THE INFORMATION PRINTED IN THIS MANUAL. ONLY QUALIFIED AND/OR CERTIFIED PERSONNEL SHOULD PERFORM INSTALLATION OF THIS FIXTURE AND ONLY THE ORIGINAL RIGGING PARTS INCLUDED WITH THIS FIXTURE SHOULD BE USED FOR INSTALLATION. ANY MODIFICATIONS TO THE FIXTURE AND/OR CERTIFIED PERSONNEL SHOULD PERFORM INSTALLATION OF THIS FIXTURE AND/OR THE INCLUDED MOUNTING HARDWARE WILL VOID THE ORIGINAL MANUFACTURER'S WARRANTY AND INCREASE THE RISK OF DAMAGE AND/OR PERSONAL INJURY.

- **PROTECTION CLASS 1 - FIXTURE MUST BE PROPERLY GROUNDED**
- **THERE ARE NO USER SERVICEABLE PARTS INSIDE THIS UNIT.**
- **DONOT ATTEMPT ANY REPAIRS YOURSELF; DOING SO WILL VOID YOUR MANUFACTURER'S WARRANTY. DAMAGES RESULTING FROM MODIFICATIONS TO THIS FIXTURE AND/OR THE DISREGARD OF SAFETY INSTRUCTIONS AND GUIDELINES IN THIS MANUAL VOID THE MANUFACTURE'S WARRANTY AND ARE NOT SUBJECT TO ANY WARRANTY CLAIMS AND/OR REPAIRS.**
- **DO NOT PLUG FIXTURE INTO A DIMMER PACK!**
- **NEVER OPEN THIS FIXTURE WHILE IN USE!**
- **UNPLUG POWER BEFORE SERVICING FIXTURE!**
- **NEVER TOUCH FIXTURE DURING OPERATION, AS IT MAY BE HOT!**
- **KEEP FLAMMABLE MATERIALS AWAY FROM FIXTURE!**
- **NEVER LOOK DIRECTLY INTO THE LIGHT SOURCE!**
- **RETINA INJURY RISK - MAY INDUCE BLINDNESS!**
- **SENSITIVE PERSONS MAY SUFFER AN EPILEPTIC SHOCK!**
- **INDOOR / DRY LOCATIONS USE ONLY!**
- **DO NOT EXPOSE FIXTURE TO RAIN AND MOISTURE!**
- **MINIMUM DISTANCE TO OBJECTS/SURFACES**
- **MUST BE 6.6 FEET (2 METERS)**
- **MAXIMUM TEMP OF EXTERNAL SURFACE 185° F (85°C)**
- **MINIMUM DISTANCE OF INFLAMMABLE MATERIALS**
- **FROM THE SURFACE 1.6 FEET (0.5 METER)**
- **DO NOT TOUCH** the fixture housing during operation. Turn OFF the power and allow approximately 60 minutes for the fixture to cool down before serving.
- **DO NOT** shake fixture, avoid brute force when installing and/or operating fixture.
- **DO NOT** operate fixture if the power cord is frayed, crimped, damaged and/or if any of the power cord connectors are damaged and do not insert into the fixture securely with ease. **NEVER** force a power cord connector into the fixture. If the power cord or any of its connectors are damaged, replace it immediately with a new one of similar power rating.
- **DO NOT** block any air ventilation slots. All fan and air inlets must remain clean and never blocked. Allow approx. 6" (15cm) between fixture and other devices or a wall for proper cooling.
- When installing fixture in a suspended environment, always use mounting hardware that is no less than M10 x 25 mm, and always install fixture with an appropriately rated safety cable.
- Always disconnect fixture from main power source before performing any type of service and/or cleaning procedure. Only handle the power cord by the plug end, never pull out the plug by tugging the wire portion of the cord.
- During the initial operation of this fixture, a light smoke or smell may emit from the interior of the fixture. This is a normal process and is caused by excess paint in the interior of the casing burning off from the heat associated with the lamp and will decrease gradually over time.
- Consistent operational breaks will ensure fixture will function properly for many years.
- **ONLY** Use original packaging and materials to transport the fixture in for service.

SAFETY GUIDELINES

POTENTIAL INTERNAL FIXTURE DAMAGE FROM EXTERNAL SOURCES OF LIGHT BEAMS

External sources of light beams from direct sunlight, lighting moving head fixtures, and lasers, which are focused directly towards the exterior housing and/or penetrate the front lens opening of ADJ lighting fixtures, can cause severe internal damage including burning to optics, dichroic color filters, glass and metal gobos, prisms, animation wheels, frost filters, iris, shutters, motors, belts, wiring, discharge lamps, and LEDs.

This issue is not specific to ADJ lighting fixtures, it is a common issue with lighting fixtures from all manufacturers. Although there is no true way to fully prevent this issue from happening, the following guidelines can prevent any potential damage from occurring if followed. Contact ADJ Service for more details.

DO NOT EXPOSE THE FIXTURE AND/OR FRONT LENS OPENING TO LIGHT BEAMS FROM DIRECT SUNLIGHT, OTHER LIGHTING MOVING HEAD FIXTURES, AND LASERS WHILE UNPACKING, INSTALLATION, USE, AND EXTENDED IDLE TIMES OUTDOORS. DO NOT FOCUS A LIGHT BEAM FROM ONE LIGHTING FIXTURE DIRECTLY TOWARDS ANOTHER.

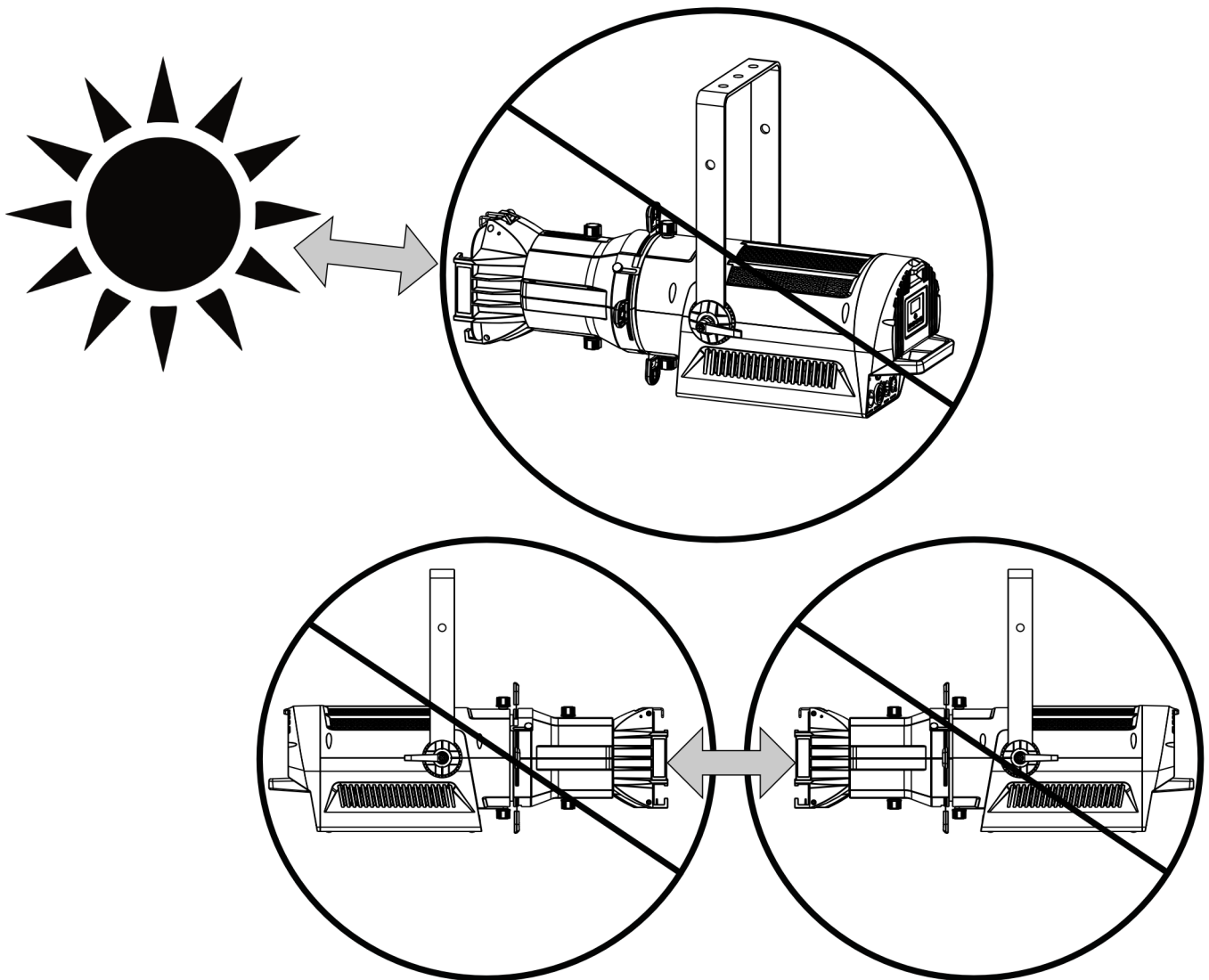

OVERVIEW

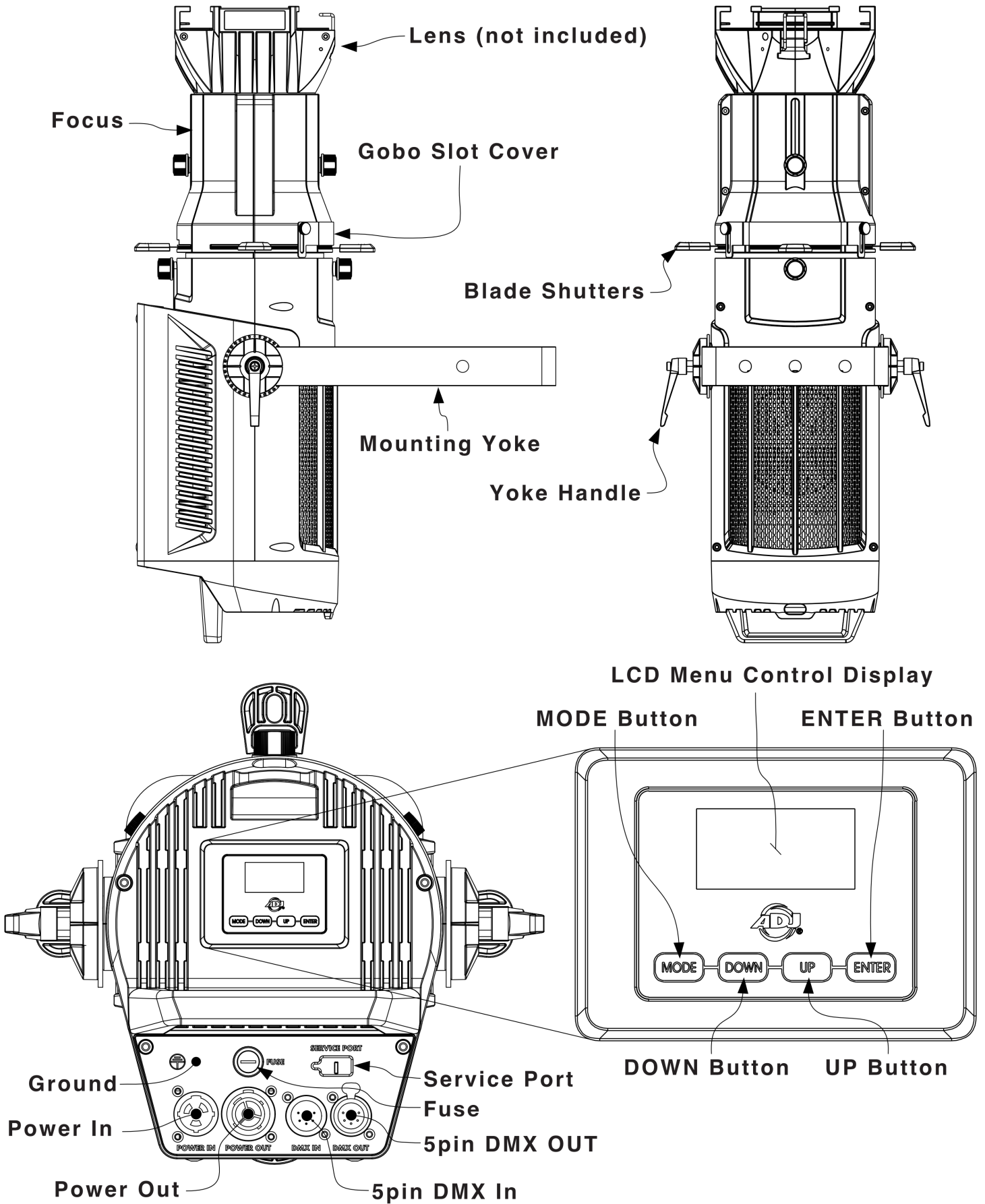

INSTALLATION



FLAMMABLE MATERIAL WARNING

Keep fixture at least 7.9in. (0.2m) away from any flammable materials, decorations, pyrotechnics, etc.



ELECTRICAL CONNECTIONS

A qualified electrician should be used for all electrical connections and/or installations.



MINIMUM DISTANCE TO OBJECTS/SURFACES MUST BE 40 FEET (12 METERS)



MAXIMUM TEMPERATURE OF EXTERNAL SURFACE 167°F (75°C)

DO NOT INSTALL THE FIXTURE IF YOU ARE NOT QUALIFIED TO DO SO!

Fixture **MUST** be installed following all local, national, and country commercial electrical and construction codes and regulations. Before rigging/mounting the fixture to any metal truss/structure or placing the fixture on any surface, a professional equipment installer **MUST** be consulted to determine if the metal truss/structure or surface is properly certified to safely hold the combined weight of the fixture, clamps, cables, and accessories.

Overhead fixture installation must always be secured with a secondary safety attachment, such as an appropriately rated safety cable that meets all local, national, and country codes and regulations.

Fixture ambient operating temperature range is **-14°F to 113°F. (-10°C to 45°C)**

Do not use this fixture outside this temperature range.

Fixture should be installed in areas outside walking paths, seating areas, or away from areas where unauthorized personnel might reach the fixture by hand.

NEVER stand directly below the fixture when rigging, removing, or servicing.

Allow approximately 15-minutes for the fixture to cool down before servicing.

RIGGING

Overhead rigging requires extensive experience, including among others calculating working load limits, installation material being used, and periodic safety inspection of all installation material and the fixture. If you lack these qualifications, do not attempt the installation yourself. Improper installation can result in bodily injury.



ALWAYS ATTACH AN APPROPRIATELY RATED SAFETY CABLE (NOT INCLUDED) THAT MEETS ALL LOCAL, NATIONAL, AND COUNTRY CODES AND REGULATIONS WHENEVER INSTALLING FIXTURE IN A SUSPENDED ENVIRONMENT!



WARNING

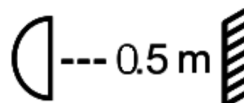

Minimum distance to lighted objects 0.5 meters.

Minimum distance of inflammable materials from the surface 0.5m.

INSTALLATION

Always ensure that the unit is firmly fixed to avoid vibration and slipping while operating. Always ensure that the structure to which you are attaching the unit is secure and is able to support a weight of 10 times the unit's weight. **Always** use safety cables that can hold 12 times the weight of the unit when installing the fixture. This equipment must be installed by a professional, and it must be installed in a place where it is out of the reach of people's grasp.

The Encore Profile Pro WW is fully operational in three different mounting positions; hanging upside-down, mounted sideways on trussing, or set on a flat level surface. **Please note that if the optional iris accessory has been installed, the unit can only be installed in an upright position with the iris handle facing upward, in order to prevent the iris from accidentally falling out.** Be sure this fixture is kept at least 12m (40ft) away from any flammable materials (decoration etc.).

OVERHEAD RIGGING: The Encore Profile Pro WW includes two rigging options.

1) OMEGA BRACKET - Mount the fixture with an appropriately rated professional grade rigging clamp (not included) to the included Omega Bracket using an M12 screw and nut (not included). With the rigging clamp securely attached to the Omega Bracket, attach the Omega Bracket to the fixture by inserting both of the 1/4-turn quick-lock fasteners into the aligning holes on the fixture yoke bracket, and turning each clockwise to secure.

MAKE SURE THE OMEGA BRACKET IS SECURELY ATTACHED BEFORE RIGGING FIXTURE!

2) MOUNTING YOKE - Mount the fixture with an appropriately rated professional grade rigging clamp (not included) to the fixture yoke bracket center hole using an M12 screw and nut (not included). **MAKE SURE THE CLAMP IS SECURELY ATTACHED BEFORE RIGGING FIXTURE!**

SAFETY CABLE: Pull the safety-cable through the opening located on the rear of the unit and over the trussing system or a safe fixation spot. Insert the end in the carabiner and tighten the safety screw. **Always** use and install a safety cable as a safety measure to prevent accidental damage and/or injury in the event the clamp fails.

CLAMP INSTALLATION

When mounting fixture to truss, be sure to secure an appropriately rated professional grade rigging clamp to either the included **Omega Brackets** using an M10 screw fitted through the center hole of the **Omega Brackets**, or to the **Mounting Yoke**. The fixture provides a built-in rigging point for a **SAFETY CABLE** (not included). Be sure to only use one of the designated rigging point for the safety cable and never secure a safety cable to the carrying handle.

*SAFETY CABLE

ALWAYS ATTACH A SAFETY CABLE WHENEVER INSTALLING THIS FIXTURE IN A SUSPENDED ENVIRONMENT TO ENSURE THE FIXTURE WILL NOT DROP IF THE CLAMP FAILS. The Safety Cable must be attached to the fixture and routed around the truss, or other secure fixation point, and both ends securely affixed to the carabiner attached at the built-in rigging points.

Mounting Holes for Omega Bracket Installation

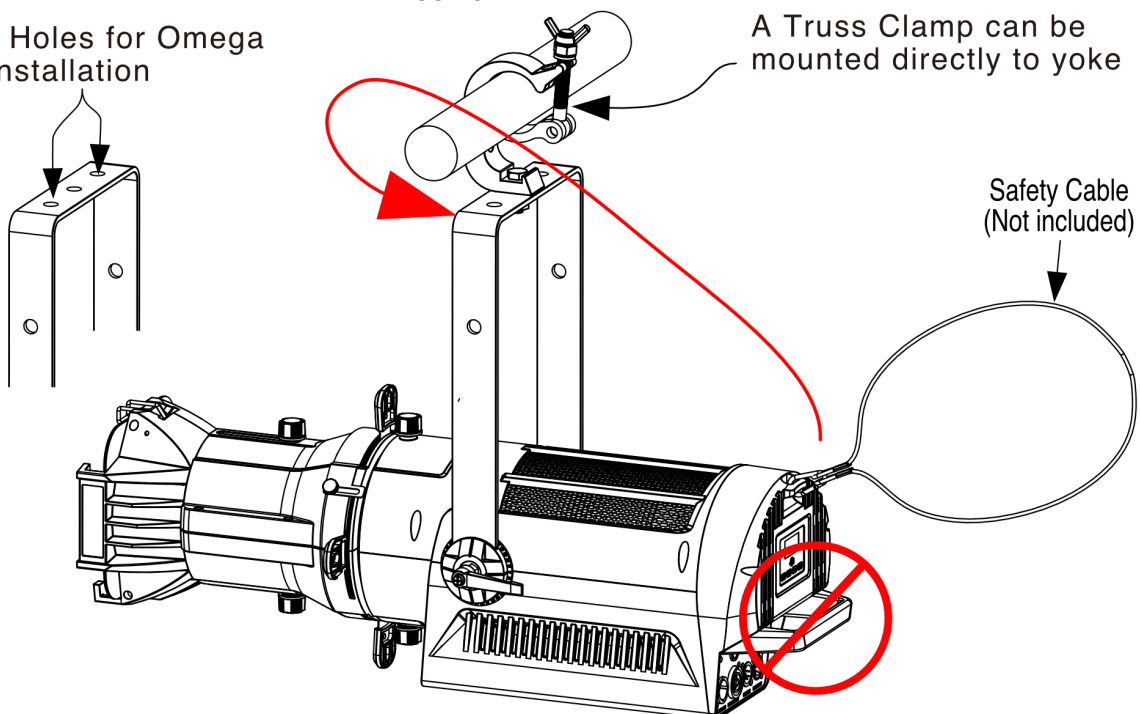

ACCESSORY INSTALLATION

LENS AND GOBO

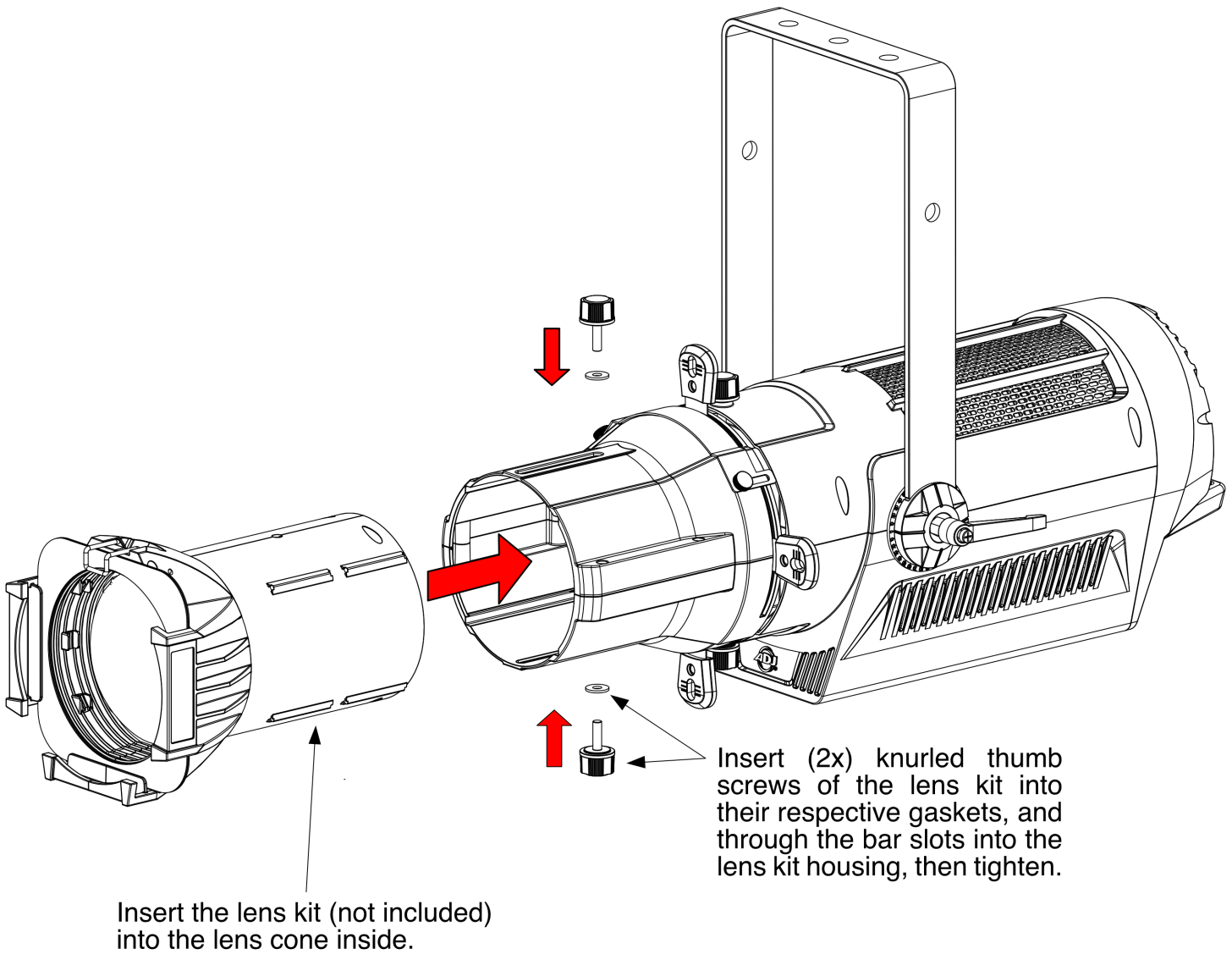

ACCESSORY INSTALLATION

IRIS

Follow the steps below to install the optional iris accessory. **Please note that when the iris is installed, the fixture should only be mounted in an upright orientation with the iris handle pointing upwards, to reduce the risk of the iris falling out.**

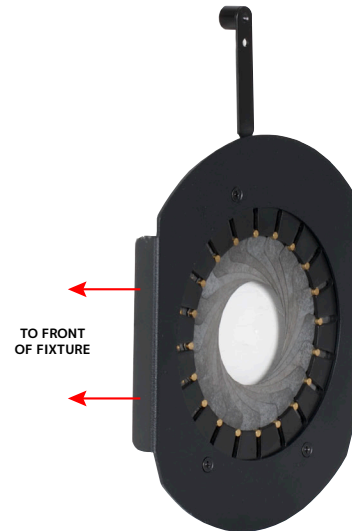

1. Locate the iris cover plate at the top of the fixture, just forward of the blade shutters. Loosen (but do not completely remove) the two thumb screws that hold the plate in place, then slide the cover plate forward to expose the iris slot.

2. Orient the iris so that the tabs along the side are facing toward the front of the fixture, as shown above.



3. Slide the iris down into the iris slot. Ensure that the tabs on the side of the iris are facing toward the front of the fixture.



4. Slide the plate back to cover the iris slot, and tighten the thumb screws to secure in place. The plate should be in contact with the handle of the iris, but be careful not to push the plate too tightly against the handle. Do not overtighten the thumb screws.

SYSTEM MENU

The fixture includes an easy to navigate system-menu control panel display where all necessary settings and adjustments are made. (See image below) During normal operation, pressing the MENU button once will access the fixture's main menu. Once in the main menu, you can navigate through the different menu's with the UP, DOWN, and MENU buttons. When you reach a field that requires adjusting, press the ENTER button to access that field and use the UP and DOWN buttons to adjust the field. Pressing the ENTER button once more to confirm your setting. You may exit the menu's at any time without making any adjustments by pressing the MENU button. If there are no changes/adjustments made within 10 seconds, the unit will revert back to the setting made under "No DMX State".

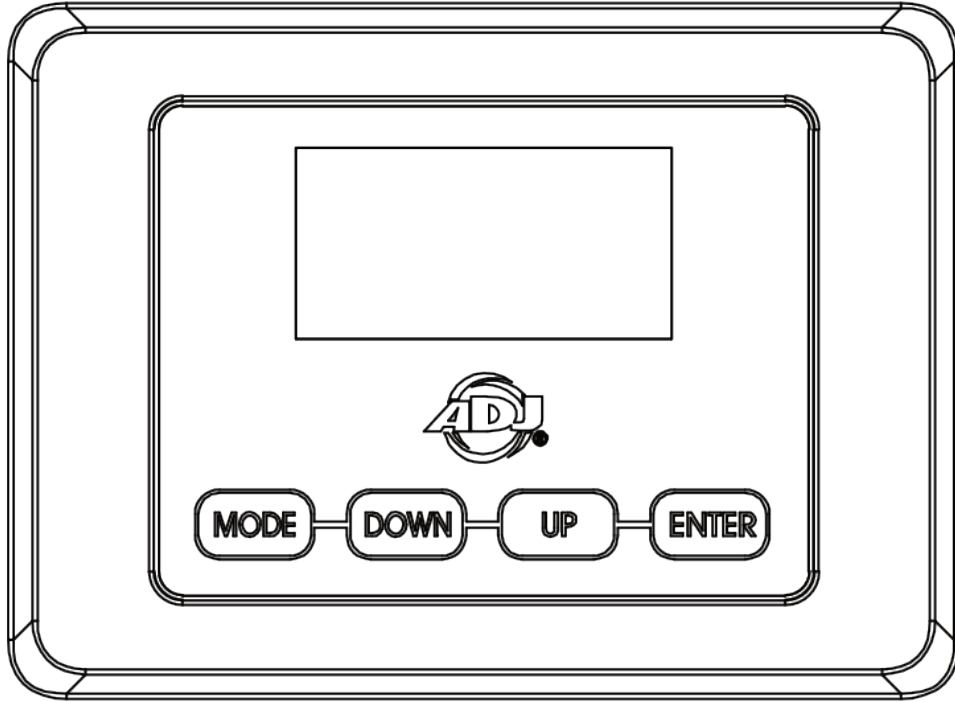

SYSTEM MENU

Supports Software Versions: 1.03

MENU	OPTIONS / VALUES (Default Settings BOLD)		DESCRIPTION		
DMX Address	001	001 - 512	Shall be used to set the units starting DMX address channel. Depending on set DMX mode, unit shall not allow to be addressed any higher that will not allow for all channels to be accessed from the console.		
DMX Channel Mode	1CH/ 2CH /3CH/6CH		Shall be used to set the units desired DMX mode.		
Personality	Status	Lost Dmx	Black/Hold	No dmx status	
	LCD Set	Display		ON/OFF	30S blackout display
		Key Lock		ON/OFF	
		Flash		ON/OFF	No DMX Flash
		Invert		ON/OFF	Screen 180° flip
	Disp. Set	Address CHAN. VAL Pri/Sec	Starting DMX Address Shall display last active DMX value Primary/Secondary		
	Temp.C/F	C/F			
	Dim Mode	Standard			
		Stage			
		TV			
		Architec			
		Theatre			
		Stage 2			
	Dim Curve	Dim Spd	0-10s		
		Square			
Linear					
Inv. Squa					
Frequen	S. Curve				
	900HZ, 1000HZ, 1100HZ, 1200HZ , 1300HZ, 1400HZ, 1500HZ, 2500HZ, 4000HZ, 5000HZ, 10KHZ, 15KHZ, 20KHZ, 25KHZ				
	PrimarySw	ON/OFF		Primary transmit signal (should be on for primary & secondary)	
USB_Data	ON/OFF				
DFSE	ON/OFF		Default Setting		
Manual Control	ManCtrl	Strobe=XXX			
		Dimmer = XXX			
Service	Calibrat	Password (50)			
		WW LED = XXX			
Info	Time Info	Current		Current fixture running time (H)	
		Total		Fixture total running time (H)	
		Last		Clear last fixture running time (H)	
		Password		clear the current running time Password = 050, total running time = 060	
		Clear		ON/OFF	
	TempInfo	xxxF/xxxC			
	Err.Info	None. Temp			
	Modellnf	Encore Profile Pro WW			
Software	Vx.xx				

SYSTEM MENU

DMX Address - In this menu you can find and set your desired DMX address.

Channel Mode - In this menu you can find and set your desired DMX channel mode.

Function Status - This menu setting is used as a precaution mode in case the DMX signal is lost or interrupted. The operating mode chosen in this menu is the running mode the fixture will go into when the DMX signal is lost. Listed below are the 3 modes.

- **Hold** - This setting will have the fixture stay in the last DMX setup.
- **Black** - This setting will have the fixture automatically go into stand by mode.

LCD Set - In this menu you are able to activate/deactivate the display blackout and activate/deactivate the display lock.

Temp.C/F - Set temperature display between Celsius and Fahrenheit.

Dim Mode - In this menu you are able to select your desired dimmer mode and adjust the dimming speed time.

Disp. Set - In this menu you are able to activate/deactivate the display blackout and activate/deactivate the display lock.

Dim Curve - Set Dimming Curve

Frequen - Set fixture frequency.

primarySW- This transmits the DMX signal via a primary & secondary control hierarchy.

Service - In this menu you are able to access and adjust/change: the calibration (effect adjust) and restore the factory settings.

USB_Data - Turns USB data access on or off.

DFSE - Turns Default Setting on or off.

Time Info - Select between Current fixture running time and Fixture total running time. Only the Fixture Current fixture running time can be cleared

TempInfo - Displays fixture temperature.

Err.Info - Displays fixture error information.

Modellnf - Displays fixture information.

Software - Displays current software version.

ManCTRL - Manual Dimmer Control.

Strobe=XXXX - Test Strobe Effect.

Calibrate - Calibrate LED, password protected.

MULTIPLE UNIT POWER LINKING

With this feature you can connect the fixtures to one another using the power cable input and output sockets.

NOTE: USE CAUTION WHEN POWER LINKING OTHER FIXTURES AS THE POWER CONSUMPTION OF OTHER MODEL FIXTURES MAY EXCEED THE MAXIMUM POWER OUTPUT ON THIS FIXTURE! CHECK SILK SCREEN FOR MAXIMUM AMPERES.

DIMMER MODE CHART

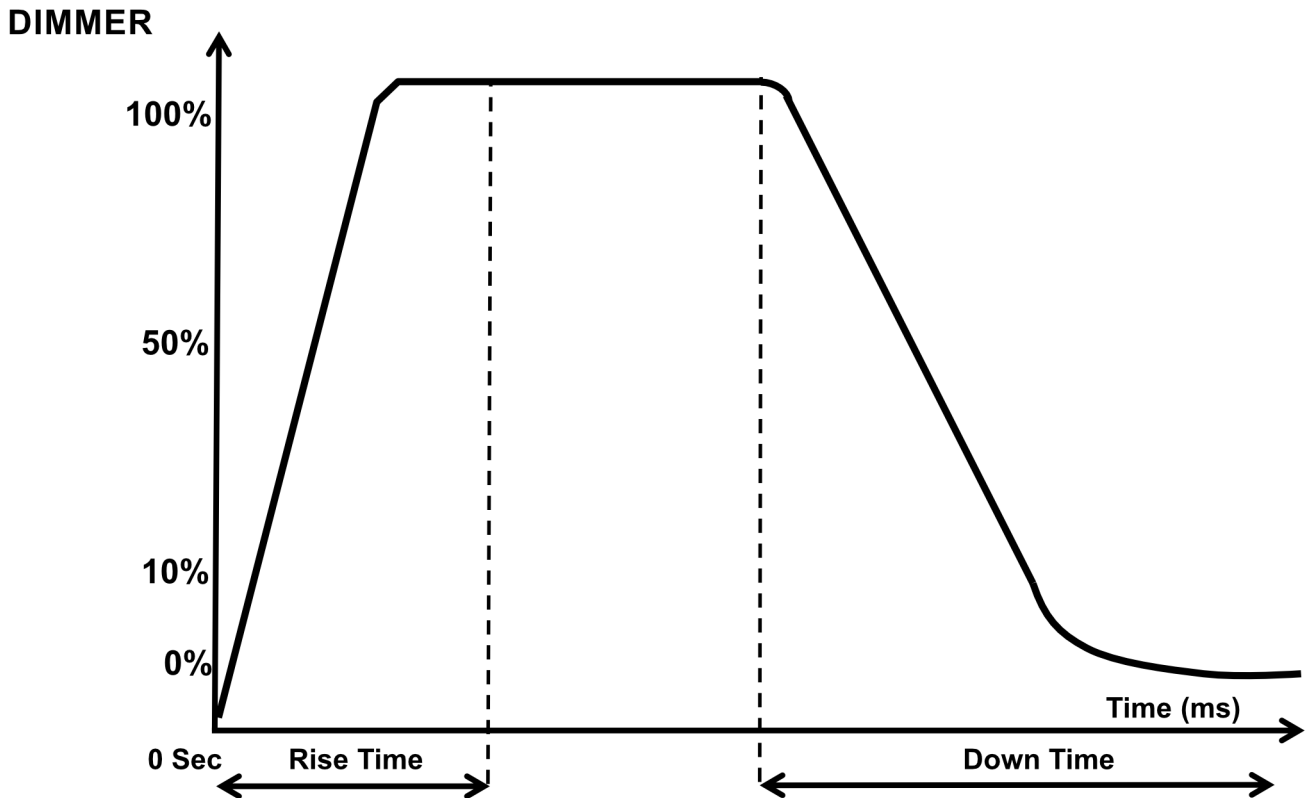

Dimming Curve Ramp Effect	0 sec Fade Time		1 sec Fade Time	
	Rise Time (ms)	Down Time (ms)	Rise Time (ms)	Down Time (ms)
Standard (default)	0	0	0	0
Stage	780	1100	1540	1660
TV	1180	1520	1860	1940
Architectural	1380	1730	2040	2120
Theatre	1580	1940	2230	2280
Stage 2	0	1100	0	1660

DMX SETUP

DMX-512: DMX is short for Digital Multiplex. This is a universal protocol used as a form of communication between intelligent fixtures and controllers. A DMX controller sends DMX data instructions from the controller to the fixture. DMX data is sent as serial data that travels from fixture to fixture via the DATA “IN” and DATA “OUT” XLR terminals located on all DMX fixtures (most controllers only have a DATA “OUT” terminal).

DMX Linking: DMX is a language allowing all makes and models of different manufactures to be linked together and operate from a single controller, as long as all fixtures and the controller are DMX compliant. To ensure proper DMX data transmission, when using several DMX fixtures try to use the shortest cable path possible. The order in which fixtures are connected in a DMX line does not influence the DMX addressing. For example; a fixture assigned a DMX address of 1 may be placed anywhere in a DMX line, at the beginning, at the end, or anywhere in the middle. When a fixture is assigned a DMX address of 1, the DMX controller knows to send DATA assigned to address 1 to that unit, no matter where it is located in the DMX chain.

Data Cable (DMX Cable) Requirements (For DMX Operation): The Encore Profile Pro WW can be controlled via DMX-512 protocol. The Encore Profile Pro WW has multiple DMX channel modes. Your unit and your DMX controller requires a 5-pin XLR connector for data input and data output. If you are making your own cables, be sure to use standard 110-120 Ohm shielded cable (This cable may be purchased at almost all pro lighting stores). Your cables should be made with a male and female XLR connector on either end of the cable. Also remember that DMX cable must be daisy chained and cannot be split.

Special Note: Line Termination. When longer runs of cable are used, you may need to use a terminator on the last unit to avoid erratic behavior. A terminator is a 110-120 ohm 1/4 watt resistor which is connected between pins 2 and 3 of a male XLR connector (DATA + and DATA -). This unit is inserted in the female XLR connector of the last unit in your daisy chain to terminate the line. Using a cable terminator (ADJ part number Z-DMX/T) will decrease the possibilities of erratic behavior.

DMX ADDRESSING

All fixtures should be given a DMX starting address when using a DMX controller, so the correct fixture responds to the correct control signal. This digital starting address is the channel number from which the fixture starts to “listen” to the digital control signal sent out from the DMX achieved by setting the correct DMX address on the digital control display on the fixture.

You can set the same starting address for all fixtures or a group of fixtures, or set different addresses for each individual fixture. Setting all fixtures to the same DMX address will cause all fixtures to react in the same way, in other words, changing the settings of one channel will affect all the fixtures simultaneously.

If you set each fixture to a different DMX address, each unit will start to “listen” to the channel number you have set, based on the quantity of DMX channels of each fixture. That means changing the settings of one channel will only affect the selected fixture.

DMX TRAITS: CHANNEL FUNCTIONS & VALUES (1/2/3/6 DMX Channels)

Supports Software Versions: ≥ 1.07					
Features subject to change without notice.					
MODE/CHANNEL				VALUE	FUNCTION
1CH	2CH	3CH	6CH		
1	1	1	1		Dimmer Intensity 8bit
				000-255	0 to 100%
	2	2	2	000-255	Dimmer Fine 16bit
					Shutter
				000-031	Shutter Closed (LEDs OFF)
				032-063	Shutter OPEN (LEDs ON)
				064-095	Strobe effect slow to fast
		3	3	096-127	Shutter OPEN (LEDs ON)
				128-159	Pulse effect in sequences
				160-191	Shutter OPEN (LEDs ON)
				192-223	Random strobe effect slow to fast
				224-255	Shutter OPEN (LEDs ON)
					Dim Modes
				000-020	Default to Unit Setting
				021-040	Standard
				041-060	Stage
				061-080	TV
				081-100	Architectural
				101-120	Theatre
				121-140	Stage 2
					Dimming Speed
				141	0.1Sec.
				142	0.2Sec.
				143	0.3Sec.
				144	0.4Sec.
				145	0.5Sec.
				146	0.6Sec.
			4	147	0.7Sec.
				148	0.8Sec.
				149	0.9Sec.
				150	1.0Sec.
				151	1.5Sec.
				152	2.0Sec.
				153	3.0Sec.
				154	4.0Sec.
				155	5.0Sec.
				156	6.0Sec.
				157	7.0Sec.
				158	8.0Sec.
				159	9.0Sec.
				160	10Sec.
				161-255	Default to Unit Setting
					Dim Curves
			5	000-020	Square
				021-040	Linear
				041-060	Inv. Squa
				061-080	S. Curve
				081-255	No Function

DMX TRAITS: CHANNEL FUNCTIONS & VALUES (1/2/3/6 DMX Channels)

Supports Software Versions: ≥ 1.07					
Features subject to change without notice.					
MODE/CHANNEL				VALUE	FUNCTION
1CH	2CH	3CH	6CH		
					LED Refresh Rates
				000-028	1200 HZ LED Refresh Rate (Default)
				029-029	1080 Hz LED Refresh Rate
				030-030	1090 Hz LED Refresh Rate
				031-031	1100 Hz LED Refresh Rate
				032-032	1110 Hz LED Refresh Rate
				033-033	1120 Hz LED Refresh Rate
				034-034	1130 Hz LED Refresh Rate
				035-035	1140 Hz LED Refresh Rate
				036-036	1150 Hz LED Refresh Rate
				037-037	1160 Hz LED Refresh Rate
				038-038	1170 Hz LED Refresh Rate
				039-039	1180 Hz LED Refresh Rate
				040-040	1190 Hz LED Refresh Rate
				041-041	1210 Hz LED Refresh Rate
				042-042	1220 Hz LED Refresh Rate
				043-043	1230 Hz LED Refresh Rate
				044-044	1240 Hz LED Refresh Rate
				045-045	1250 Hz LED Refresh Rate
				046-046	1260 Hz LED Refresh Rate
				047-047	1270 Hz LED Refresh Rate
				048-048	1280 Hz LED Refresh Rate
				049-049	1290 Hz LED Refresh Rate
				050-050	1300 Hz LED Refresh Rate
				051-051	1310 Hz LED Refresh Rate
				052-052	1320 Hz LED Refresh Rate
			6	053-053	1330 Hz LED Refresh Rate
				054-054	1340 Hz LED Refresh Rate
				055-055	1350 Hz LED Refresh Rate
				056-056	1360 Hz LED Refresh Rate
				057-057	1370 Hz LED Refresh Rate
				058-058	1380 Hz LED Refresh Rate
				059-059	1390 Hz LED Refresh Rate
				060-060	1400 Hz LED Refresh Rate
				061-061	1410 Hz LED Refresh Rate
				062-062	1420 Hz LED Refresh Rate
				063-063	1430 Hz LED Refresh Rate
				064-064	1440 Hz LED Refresh Rate
				065-065	1450 Hz LED Refresh Rate
				066-066	1460 Hz LED Refresh Rate
				067-067	1470 Hz LED Refresh Rate
				068-068	1480 Hz LED Refresh Rate
				069-069	1490 Hz LED Refresh Rate
				070-070	1500 Hz LED Refresh Rate
				071-071	2500 Hz LED Refresh Rate
				072-072	4000 Hz LED Refresh Rate
				073-073	5000 Hz LED Refresh Rate
				074-074	6000 Hz LED Refresh Rate
				075-075	10K Hz LED Refresh Rate
				076-076	15K Hz LED Refresh Rate
				077-077	20K Hz LED Refresh Rate
				078-078	25K Hz LED Refresh Rate
				079-079	Disable LED Refresh Rate
				080-255	No Function

SPECIFICATIONS

SOURCE

260W Warm White LED Engine

50,000 Hour Average LED Life*

*LED Life may vary depending on several factors including but not limited to:

Environmental Conditions, Power/Voltage, Usage Patterns (On-Off Cycling), Control, and Dimming.

PHOTOMETRIC DATA

>97CRI 10,000 Total Lumens* (*with 26° lens)

3200K Color Temperature

EFFECTS

Electronic Strobe and Dimming

Variable Dimming Curves and Dimming Modes

GOBOS

Supports "B" Size Metal, HT Transparency Gobos*

*Gobos not included.

CONTROL / CONNECTIONS

(4) DMX Channel Modes (1 / 2 / 3 / 4)

Adjustable Refresh Rates (900-1500, 25,000 Hz)

4 Button Control Panel

LED Menu Display

5pin XLR In/Out

IP65 Locking Power In/Out

SIZE / WEIGHT

Length: 26.9" (688mm) (Lens In)

Width: 111.3" (287mm)

Vertical Height: 17.7" (450mm)

Weight: 20.0 lbs. (9.1 kg)

ELECTRICAL / THERMAL

Quiet Fan Cooling

AC 100-240V - 50/60Hz

295W Max Power Consumption

Power Linking: 8pcs Max @240V

-10° to 45°C

BTU: 0.28

BTU/H: 1005.95

APPROVALS / RATINGS

IP20

INCLUDED ITEMS

(1) IP65 Locking Power Cable

(1) Gobo Holder

Specifications and documentation subject to change without notice.

DIMENSIONAL DRAWINGS

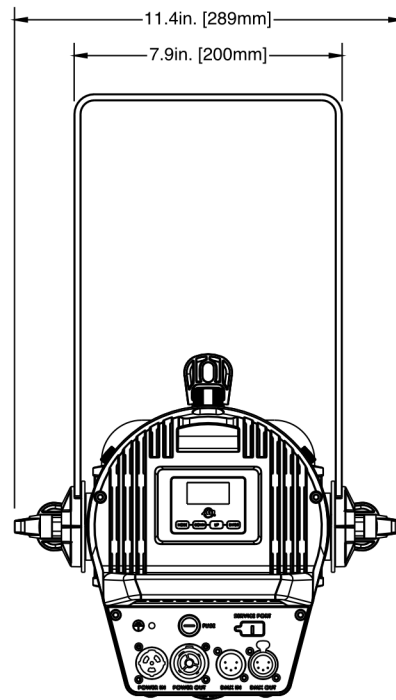
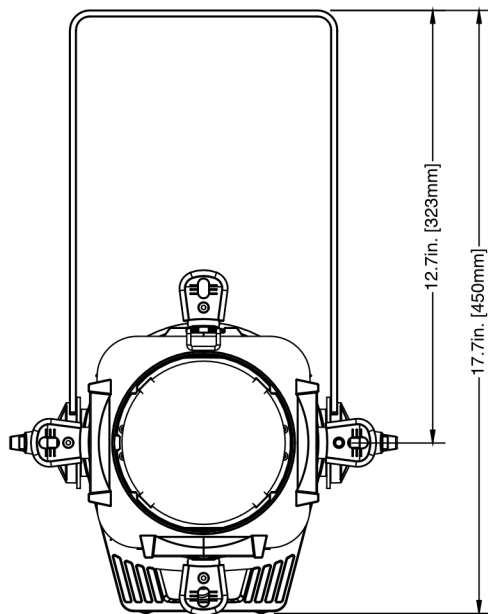
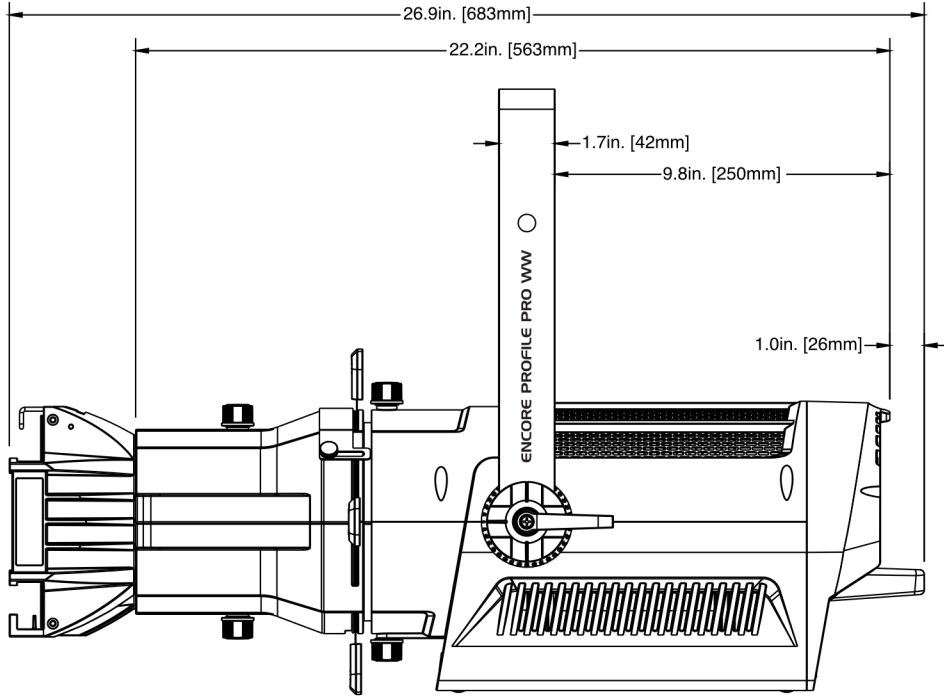
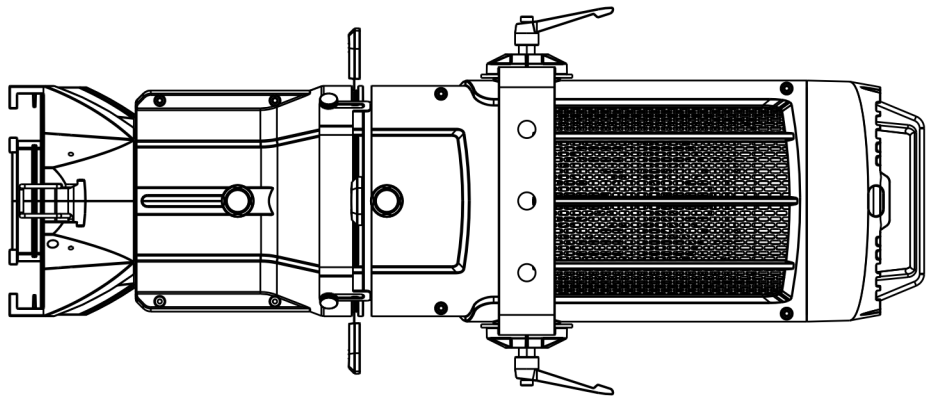

DIMENSIONAL DRAWINGS- OPTIONAL LENS KITS

Lens Kits are not included

LENS KIT: 5°

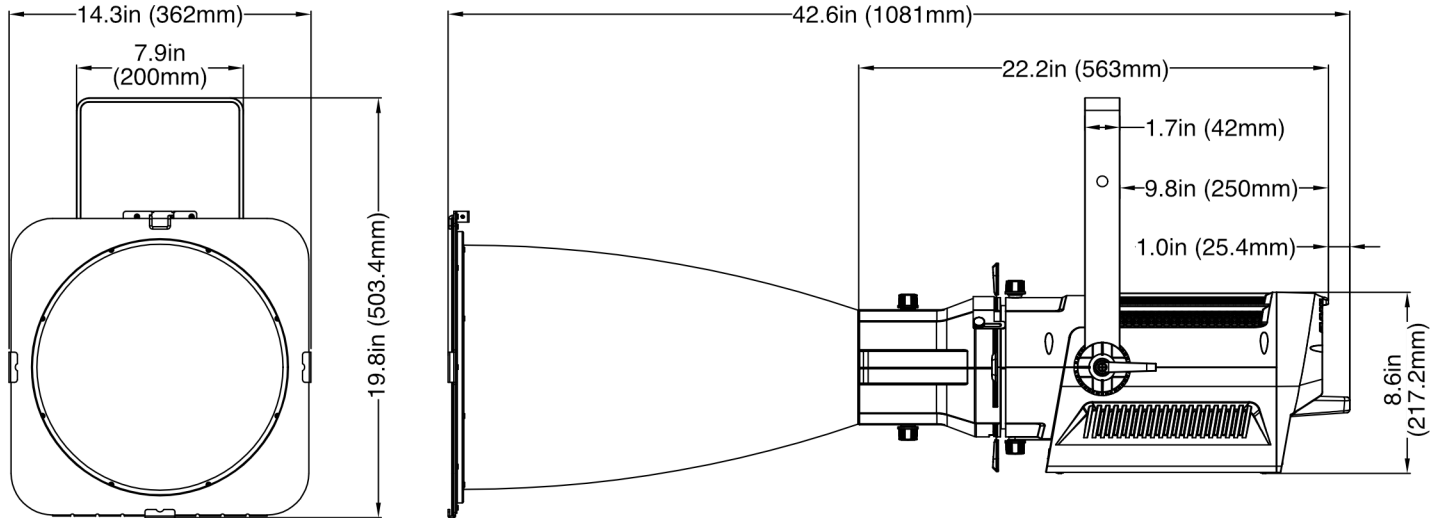

LENS KIT: 10°

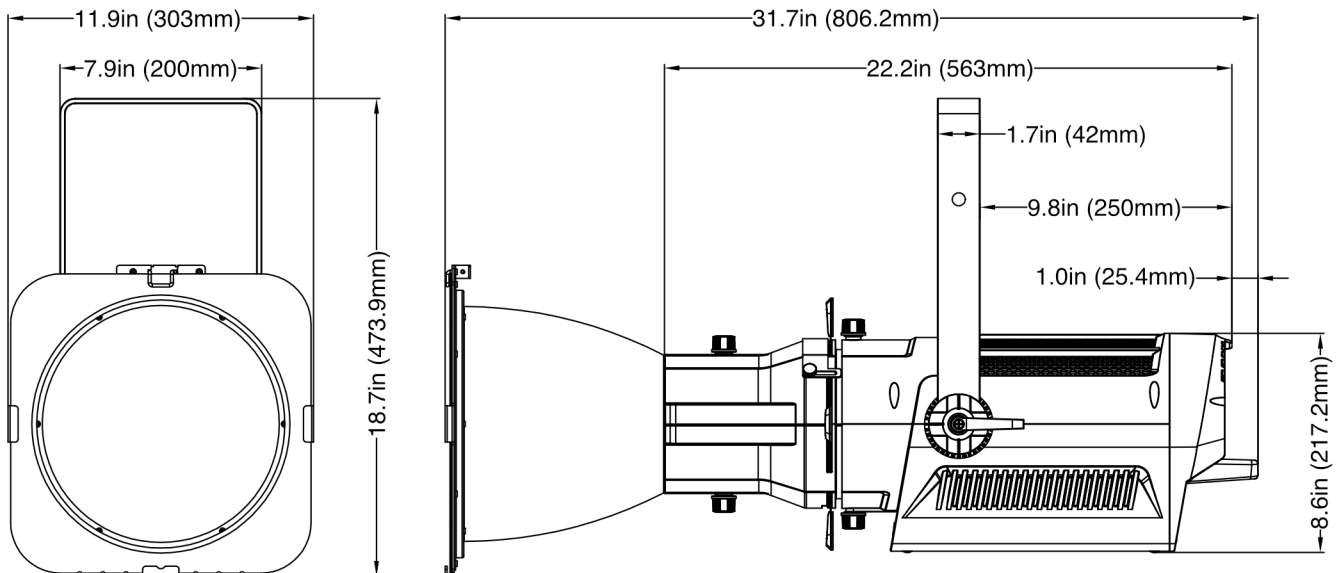

DIMENSIONAL DRAWINGS - OPTIONAL LENS KITS

Lens Kits are not included

LENS KIT: 14°

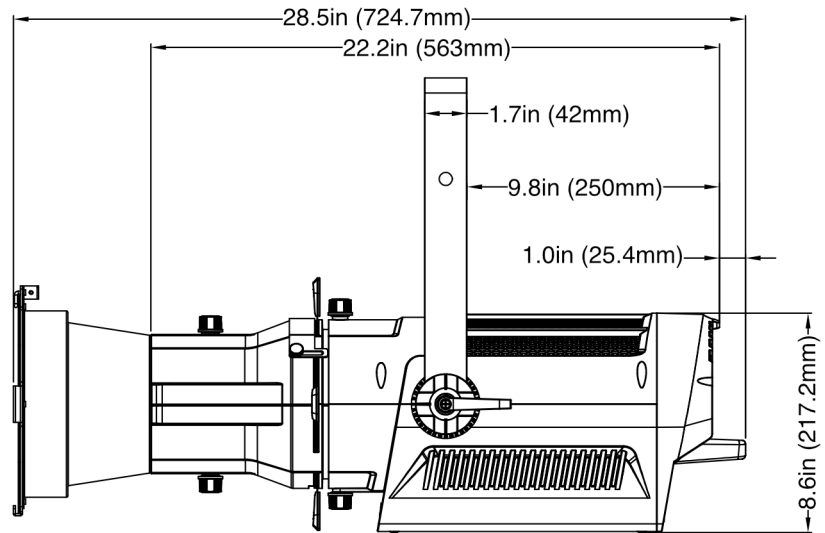
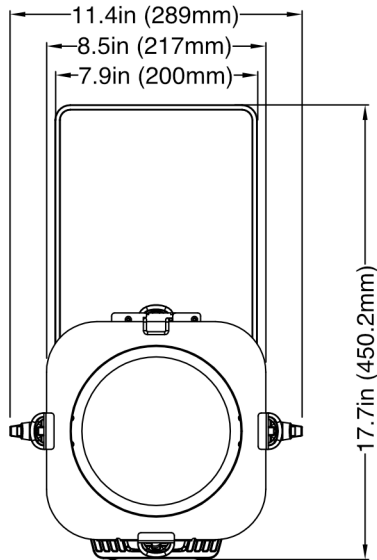

LENS KIT: 19°, 26°, 36°, 50°

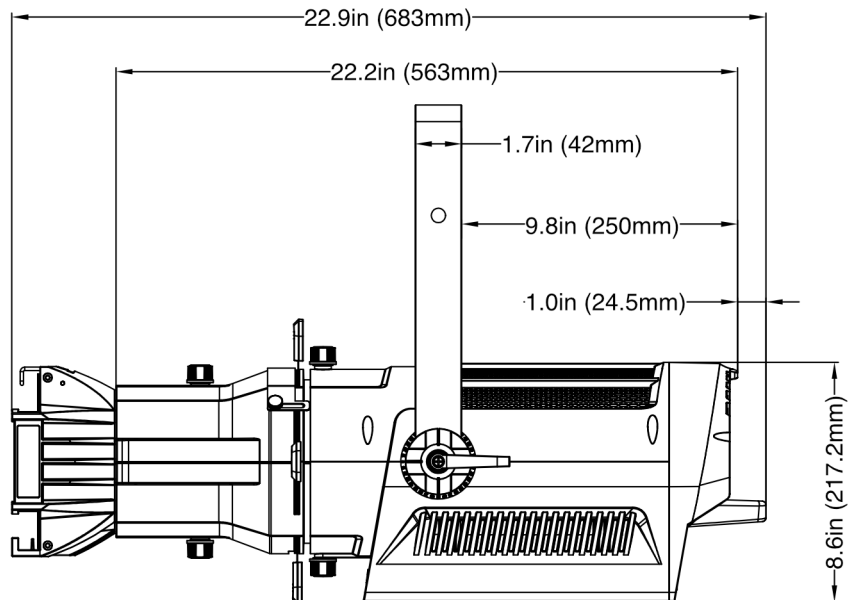
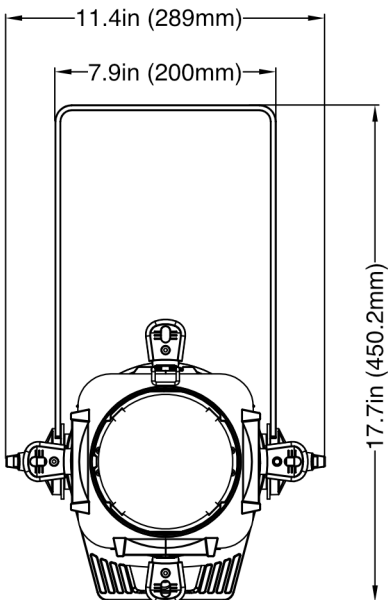

DIMENSIONAL DRAWINGS - OPTIONAL LENS KITS

Lens Kits are not included

ZOOM LENS KIT: 15° - 30°

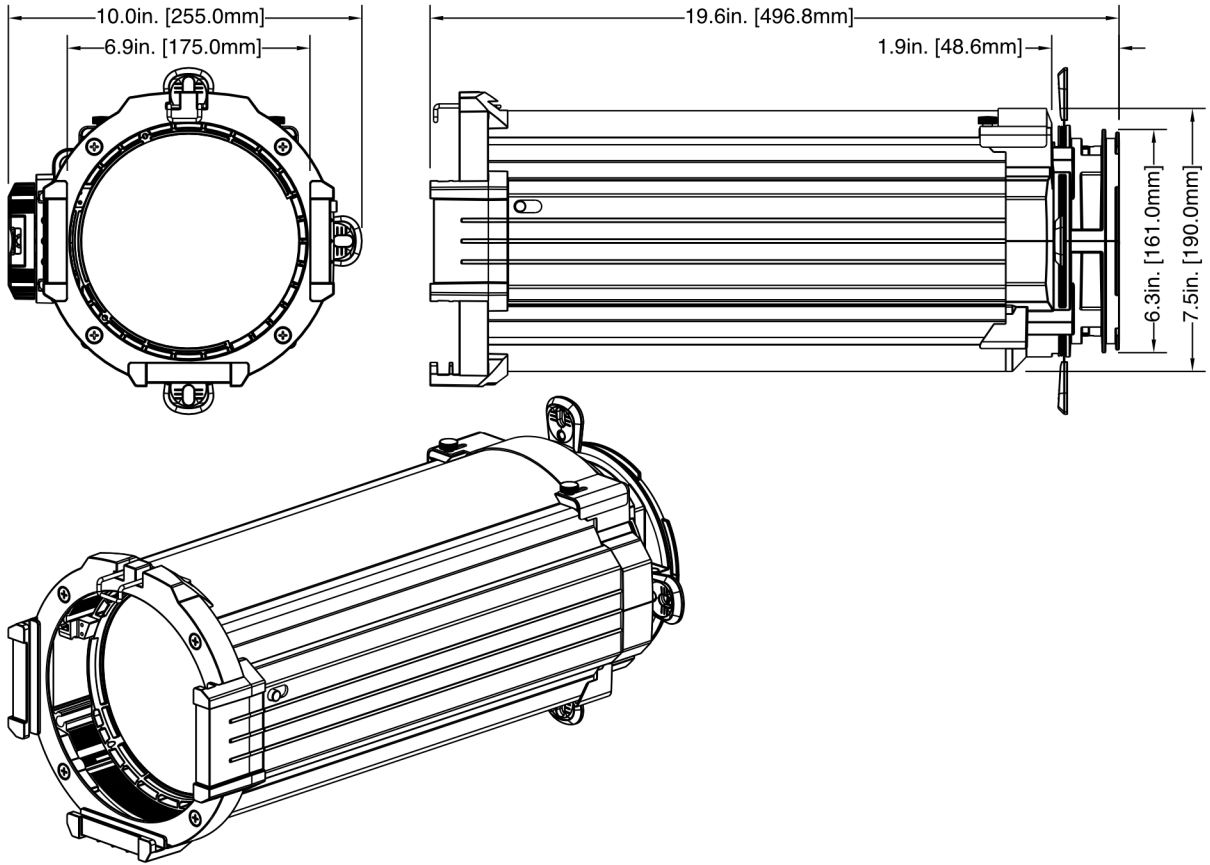

ZOOM LENS KIT: 25° - 50°

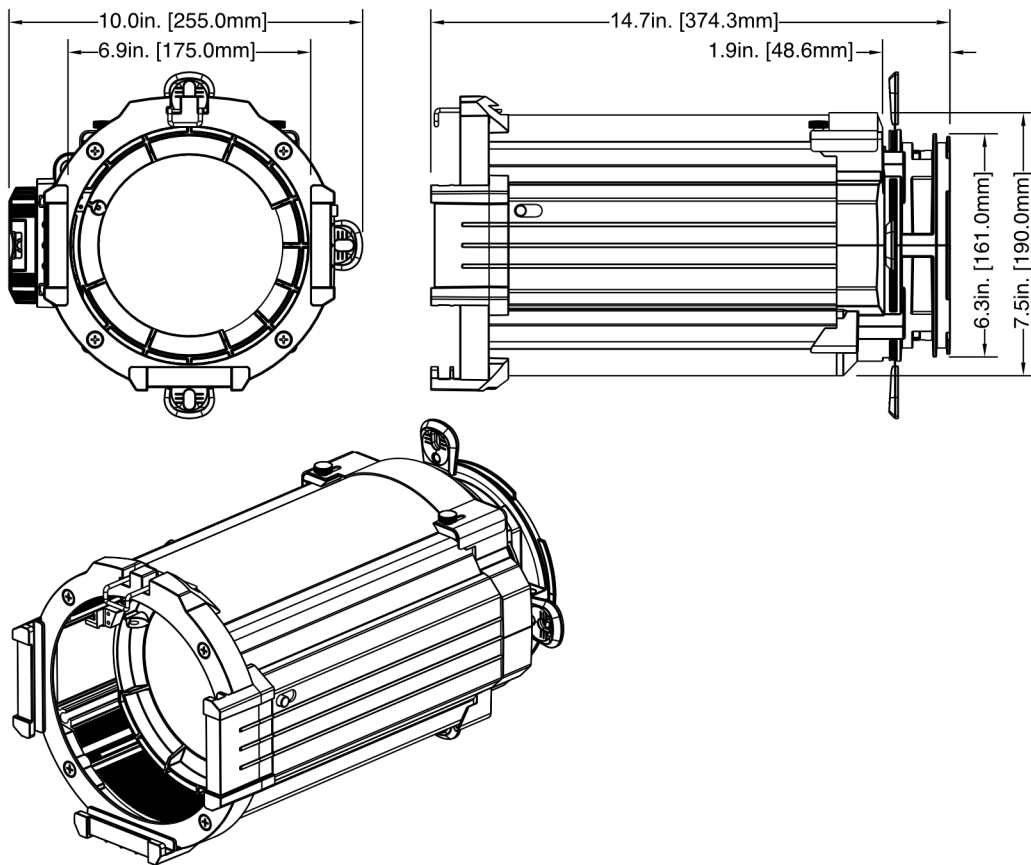

TROUBLESHOOTING

Listed below are a few common problems the user may encounter, with solutions.

Unit not powered on:

- Check that the fixture is plugged in.

Unit not responding to DMX:

- Check that the DMX cables are connected properly and are wired correctly (pin 3 is “hot”; on some other DMX devices pin 2 may be ‘hot’). Also, check that all cables are connected to the right connectors; it does matter which way the inputs and outputs are connected.

DISCONNECT POWER BEFORE PERFORMING ANY MAINTENANCE!

CLEANING

Frequent cleaning is recommended to ensure proper function, optimized light output, and an extended life. The frequency of cleaning depends on the environment in which the fixture operates: damp, smoky, or particularly dirty environments can cause greater accumulation of dirt on the fixture’s optics. Clean the external lens surface periodically with a soft cloth to avoid dirt/debris accumulation.

NEVER use alcohol, solvents, or ammonia-based cleaners.

MAINTENANCE

Regular inspections are recommended to ensure proper function and extended life.

There are no user serviceable parts inside this fixture, please refer all other service issues to an authorized ADJ service technician. Should you need any spare parts, please order genuine parts from your local ADJ dealer.

Please refer to the following points during routine inspections:

- A detailed electrical check by an approved electrical engineer every three months, to make sure the circuit contacts are in good condition in order to prevent overheating.
- Be sure all screws and fasteners are securely tightened at all times. Loose screws may fall out during normal operation, resulting in damage or injury as larger parts could fall.
- Check for any deformations on the housing, color lenses, rigging hardware, and rigging points (ceiling, suspension, trussing). Deformations in the housing could allow for dust or liquids to enter into the fixture. Damaged rigging points or unsecured rigging could cause fixture to fall and seriously injure a person(s).
- Electric power supply cables must not show any damage, material fatigue, or sediments.
- **NEVER** remove the ground prong from the power cable.

OPTIONAL ACCESSORIES

SKU#		Models
US	EU	
EPP IRIS	PENDING	EPP001
EPL140	PENDING	EP Lens 14 (14° Lens)
EPL166	PENDING	EP Lens FZ (Zoom Fresnel Lens)
EPL190	1237000308	EP Lens 19 (19° Lens)
EPL260	1237000309	EP Lens 26 (26° Lens)
EPL360	1237000310	EP Lens 36 (36° Lens)
EPL500	1237000311	EP Lens 50 (50° Lens)
SIP064	PENDING	1.64ft. IP65 male to female twist lock power link cable
SIP113	PENDING	3ft. IP65 male to female twist lock power link cable
SIP126	PENDING	5ft. IP65 male to female twist lock power link cable
SIP139	PENDING	10ft. IP65 male to female twist lock power link cable
SIP152	PENDING	16ft. IP65 male to female twist lock power link cable
SIP165	PENDING	25ft. IP65 male to female twist lock power link cable
SIP178	PENDING	50ft. IP65 male to female twist lock power link cable
SIP191	PENDING	100ft. IP65 male to female twist lock power link cable



FCC STATEMENT

This device complies with Part 15 of the FCC Rules. Operation is subject to the following two conditions: (1) this device may not cause harmful interference, and (2) this device must accept any interference received, including interference that may cause undesired operation.

FCC RADIO FREQUENCY INTERFERENCE WARNINGS & INSTRUCTIONS

This product has been tested and found to comply with the limits as per Part 15 of the FCC Rules. These limits are designed to provide reasonable protection against harmful interference in a residential installation. This device uses and can radiate radio frequency energy and, if not installed and used in accordance with the included instructions, may cause harmful interference to radio communications. However, there is no guarantee that interference will not occur in a particular installation. If this device does cause harmful interference to radio or television reception, which can be determined by turning the device off and on, the user is encouraged to try to correct the interference by one or more of the following methods:

- Reorient or relocate the device.
- Increase the separation between the device and the receiver.
- Connect the device to an electrical outlet on a circuit different from which the radio receiver is connected.
- Consult the dealer or an experienced radio/TV technician for help.

Europe Energy Saving Notice

Energy Saving Matters (EuP 2009/125/EC)

Saving electric energy is a key to help protecting the environment. Please turn off all electrical products when they are not in use. To avoid power consumption in idle mode, disconnect all electrical equipment from power when not in use. Thank you

