



15 HEX BAR IP



User Manual

©2023 ADJ Products, LLC all rights reserved. Information, specifications, diagrams, images, and instructions herein are subject to change without notice. ADJ Products, LLC logo and identifying product names and numbers herein are trademarks of ADJ Products, LLC. Copyright protection claimed includes all forms and matters of copyrightable materials and information now allowed by statutory or judicial law or hereinafter granted. Product names used in this document may be trademarks or registered trademarks of their respective companies and are hereby acknowledged. All non-ADJ Products, LLC brands and product names are trademarks or registered trademarks of their respective companies.

ADJ Products, LLC and all affiliated companies hereby disclaim any and all liabilities for property, equipment, building, and electrical damages, injuries to any persons, and direct or indirect economic loss associated with the use or reliance of any information contained within this document, and/or as a result of the improper, unsafe, insufficient and negligent assembly, installation, rigging, and operation of this product.

DOCUMENT VERSION



Due to additional product features and/or enhancements, an updated version of this document may be available online.

Please check www.adj.com for the latest revision/update of this manual before beginning installation and/or programming.

Date	Document Version	Software Version	DMX Channels	Notes
06/10/2019	1	1.02	6/9/12/14/17/30/33/38 /41/60	Initial release
09/16/2020	2	1.03	No Change	Updated primary/secondary
02/19/2021	3	1.05	No Change	Updated system menu and color macro chart
06/24/2021	4	N/C	No Change	Approved/rating updated
12/27/2021	5	1.07	No Change	Updated system menu
10/27/2022	6	N/C	No Change	Updated IP65 statement
05/02/2023	7	N/C	No Change	Added Primary-Secondary Set Up and Fan Modes; updated IP65 Notice

Europe Energy Saving Notice

Energy Saving Matters (EuP 2009/125/EC)

Saving electric energy is a key to help protecting the environment. Please turn off all electrical products when they are not in use. To avoid power consumption in idle mode, disconnect all electrical equipment from power when not in use. Thank you!

TABLE OF CONTENTS

Introduction	4
Features Warranty Registration	5
Safety Precautions	6
IP65 Notice	8
Overview	9
Installation	10
Manual Tilt Adjustment Connections	12
DMX Set Up	13
System Menu	14
Primary-Secondary Set Up	18
Fan Modes and Low Noise Operation	19
DMX Addressing	20
DMX Traits	21
Color Macro Chart	26
Pixel Zones Dimmer Curves Chart	28
Glare Shield Installation Filter Installation	29
Dimensional Drawing	30
Multi Unit Power Linking Trouble Shooting Cleaning	31
Limited Warranty (USA Only)	32
Specifications	33

INTRODUCTION

Unpacking: Thank you for purchasing the 15 Hex Bar IP by ADJ Products, LLC. Every unit has been thoroughly tested and has been shipped in perfect operating condition. Carefully check the shipping carton for damage that may have occurred during shipping. If the carton appears to have been damaged, carefully inspect your fixture for any damage and be sure all accessories necessary to operate the unit have arrived intact. In the event that damage has been found or parts are missing, please contact our toll free customer support number for further instructions. Do not return this unit to your dealer without first contacting customer support.

Introduction: The 15 Hex Bar IP is a DMX intelligent, IP rated LED wash fixture. This fixture can be used in a stand alone mode or connected in a Primary/Secondary configuration. **This product is intended to be used by professionally trained personnel only and is not suitable for private use.**

Customer Support: Contact ADJ Service for any product related service and support needs. Also visit forums.adj.com with questions, comments or suggestions.

Parts: To purchase parts online visit <http://parts.adj.com>

ADJ SERVICE USA - Monday - Friday 8:00am to 4:30pm PST
Voice: 800-322-6337 | Fax: 323-582-2941 | support@adj.com

ADJ SERVICE EUROPE - Monday - Friday 08:30 to 17:00 CET
Voice: +31 45 546 85 60 | Fax: +31 45 546 85 96 | support@americandj.eu

ADJ PRODUCTS LLC USA
6122 S. Eastern Ave. Los Angeles, CA. 90040
323-582-2650 | Fax 323-532-2941 | www.adj.com | info@adj.com

ADJ SUPPLY Europe B.V
Junostraat 2 6468 EW Kerkrade, The Netherlands
+31 (0)45 546 85 00 | Fax +31 45 546 85 99
www.adj.eu | info@americandj.eu

ADJ PRODUCTS GROUP Mexico
AV Santa Ana 30 Parque Industrial Lerma, Lerma, Mexico 52000
+52 (728) 282-7070

Caution! There are no user serviceable parts inside this unit. Do not attempt any repairs yourself, as doing so will void your manufacturer's warranty. In the unlikely event your unit may require service, please contact ADJ Products, LLC.

PLEASE recycle the shipping carton when ever possible.

FEATURES

- Multi-Colors
- Five Operating Modes
- Electronic Dimming 0-100%
- DMX-512 protocol
- IP65 Locking 5-Pin XLR Connections In/Out
- 10 DMX Channel Modes: 6 / 9 / 12 / 14 / 17 / 30 / 33 / 38 / 41 / 60
- Multiple Unit Power Linking (see **Multiple Unit Power Linking** section of this manual)

INCLUDED:

- 1 x IP65 Locking Power Cable
- 1 x Removable Frost/Diffuser Filter 1 x Removable Glare Shield
- 2 x Omega Brackets

WARRANTY REGISTRATION

The 15 Hex Bar IP carries a 2 year limited warranty. Please fill out the enclosed warranty card to validate your purchase. All returned service items, whether under warranty or not, must be freight pre-paid and accompanied by a return authorization (R.A.) number. The R.A. number must be clearly written on the outside of the return package. A brief description of the problem, as well as the R.A. number, must also be written down on a piece of paper included in the shipping carton. If the unit is under warranty, you must provide a copy of your proof of purchase invoice. You may obtain an R.A. number by contacting our customer support team on our customer support number. All packages returned to the service department not displaying an R.A. number on the outside of the package will be returned to the shipper.

SAFETY PRECAUTIONS

- Do not attempt to operate this unit if the power cord has been frayed or broken.
- Do not attempt to remove or break off the ground prong from the electrical cord. This prong is used to reduce the risk of electrical shock and fire in the event of an internal short.
- Disconnect from main power before making any type of connection.
- Do not remove the cover for any reason. There are no user serviceable parts inside.
- Never operate this unit with the cover removed.
- Never plug this unit in to a dimmer pack
- Always be sure to mount this unit in an area that will allow proper ventilation. Allow about 6” (15cm) between this device and a wall.
- Do not attempt to operate this unit if it has been damaged in any way.
- During long periods of non-use, disconnect the unit’s main power.
- Always mount this unit in safe and stable matter.
- Power-supply cords should be routed so that they are not likely to be walked on or pinched by items placed upon or against them, paying particular attention to the point at which they exit from the unit.
- **Cleaning** - The fixture should be cleaned only as recommended by the manufacturer. See the **Cleaning** section of this manual details.
- **Heat** - The appliance should be situated away from heat sources such as radiators, heat registers, stoves, or other appliances (including amplifiers) that produce heat.
- The fixture should be serviced by qualified service personnel when:
 - A. The power-supply cord or the plug has been damaged.
 - B. Objects have fallen onto, or liquid has been spilled into, the fixture.
 - C. The fixture does not appear to operate normally or exhibits a marked change in performance.
 - D. The fixture has fallen and/or been subjected to extreme handling.

SAFETY PRECAUTIONS



HIGH INTENSITY ULTRAVIOLET LIGHT

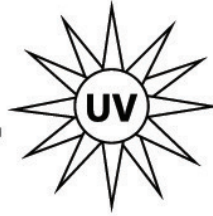

**AVOID DIRECT EYE & SKIN EXPOSURE.
WEAR PROPER EYE & SKIN PROTECTION.
SEE MANUAL FOR SAFETY INSTRUCTIONS.**

RISK GROUP 3 - RISK OF EXPOSURE TO ULTRAVIOLET (UV) RADIATION!

FIXTURE EMITS HIGH INTENSITY ULTRAVIOLET (UV) LIGHT.

WEAR PROPER EYE AND SKIN PROTECTION.

AVOID PROLONGED PERIODS OF EXPOSURE.

AVOID WEARING WHITE COLOR CLOTHING AND/OR USING (UV) PAINTS ON SKIN.

AVOID DIRECT EYE AND/OR SKIN EXPOSURE AT DISTANCES SHORTER THAN 11 feet (3.3m).

DO NOT OPERATE FIXTURE WITH DAMAGED OR MISSING EXTERNAL COVER PROTECTIVE LENS.

DO NOT LOOK DIRECTLY INTO THE (UV) LIGHT AND/OR VIEW (UV) LIGHT DIRECTLY WITH OPTICAL INSTRUMENTS THAT MAY CONCENTRATE THE LIGHT/RADIATION OUTPUT.

INDIVIDUALS SUFFERING FROM A RANGE OF EYE CONDITIONS, SUNLIGHT EXPOSURE DISORDERS, OR INDIVIDUALS USING PHOTSENSITIVE MEDICATION MAY EXPERIENCE DISCOMFORT IF EXPOSED TO THE ULTRAVIOLET (UV) LIGHT EMITTED FROM THIS FIXTURE.

IP65 NOTICE

The International Protection (IP) rating system is commonly expressed as “IP” (Ingress Protection) followed by two numbers (i.e. IP65), where the numbers define the degree of protection. The first digit (Foreign Bodies Protection) indicates the extent of protection against particles entering the fixture, and the second digit (Water Protection) indicates the extent of protection against water entering the fixture. An **IP65** rated lighting fixture is designed and tested to protect against the ingress of dust (6), and low-pressure water jets from any direction (5).

NOTE: THIS FIXTURE IS INTENDED FOR TEMPORARY OUTDOOR USE ONLY!

Maritime/Coastal Environment Installations: A coastal environment is seaside adjacent, and caustic to electronics through exposure to atomized salt-water and humidity, whereas maritime is anywhere within 5-miles of a coastal environment.



NOT suitable for maritime/coastal environment installations. Installing this fixture in a maritime/coastal environment may cause corrosion and/or excessive wear to the interior and/or exterior components of the fixture. Damages and/or performance issues resulting from installation in a maritime/coastal environment will void the manufactures warranty, and will NOT be subject to any warranty claims and/or repairs.

Maritime installations require additional preparation, and additional service intervals may be needed given the maritime use. In general, IP ratings presuppose freshwater conditions VS maritime conditions, which are typically more “caustic” to IP fixtures (both internally and externally). A duty-cycle may also be needed when units are not in use. During times of high humidity and colder temperatures, condensation may occur internally so the fixture may require a duty-cycle to bring it up to running temperature, allowing any accumulation of moisture to be expelled via the vent valve. Recommendations can change based on installation environmental circumstances. A waterproof dome or similar device is recommended for use in permanent outdoor installations. When using a dome, refer to manufacturer recommendations for duty-cycle.

NOTE: NOT ALL FEATURES LISTED ARE AVAILABLE ON ALL FIXTURES; THE FOLLOWING INSTRUCTIONS MAY NOT APPLY. CONTACT SUPPORT FOR ADDITIONAL DETAILS.

Exterior Maintenance: Inspect the exterior every 30-days. The unit must be powered off/disconnected. Inspect optics to determine if the lens is obstructed, then clean optics and chassis accordingly. Based on initial finding, schedule maintenance accordingly, keeping in mind that exterior maintenance will be required. Even if the luminaires are NOT in use, maintenance will still be needed given its location (exterior use). The use of a durable type of wax on the chassis is recommended since it will help prevent contaminant build up. Inspect both power and data lines for any signs of contaminants or corrosion. Periodically reapplying di-electric grease, especially in coastal environments. If any signs of corrosion/contaminants are present, clean thoroughly, and/or replace connectors, then reapply di-electric grease. Typically, this should be done annually, or any time an opportunity presents itself. As a preventive measure, annual replacement of both vent valves is recommended. The vent valve membrane can become contaminated and/or clogged causing improper venting of humidity within the luminaire. Inspect all mounting hardware as a precaution.

Interior Maintenance: Inspect the interior every 30-days. The unit must be powered off/disconnected.

- Inspect zoom/focus mechanism, clean optics, lubricate linear bearings (Krytox oil) as needed, inspect belts for wear
- Inspect all rotating effect wheels, manually rotate them, note any resistance
- Inspect all remaining rotating belts for any wear
- Inspect all fans, clean as needed, check rotation, check connections
- Inspect CMY module, manually move flags and check for signs of resistance, and if needed, clean guide rods first, then reapply a thin layer of grease (moly lube)
- Clean interior with low-volume compressed air, then clean optics prior to reassembly of head covers

Although the base has limited moving parts, the pan belt should also be inspected for wear. Remember to always perform an IP test anytime a cover is removed.

There is no specific time frame regarding the routine replacement of parts such as belts/stepper motors, PCBs, or LEDs. These items should only be replaced on an as needed bases, except for cooling fans, which should be replaced once the luminaries reach 10,000-hours. This is a prophylactic measure intended to keep the unit running as cool as possible, insuring proper function of all internal components. A complete service breakdown is available, please contact service@adj.com for any needed parts or manuals.

OVERVIEW

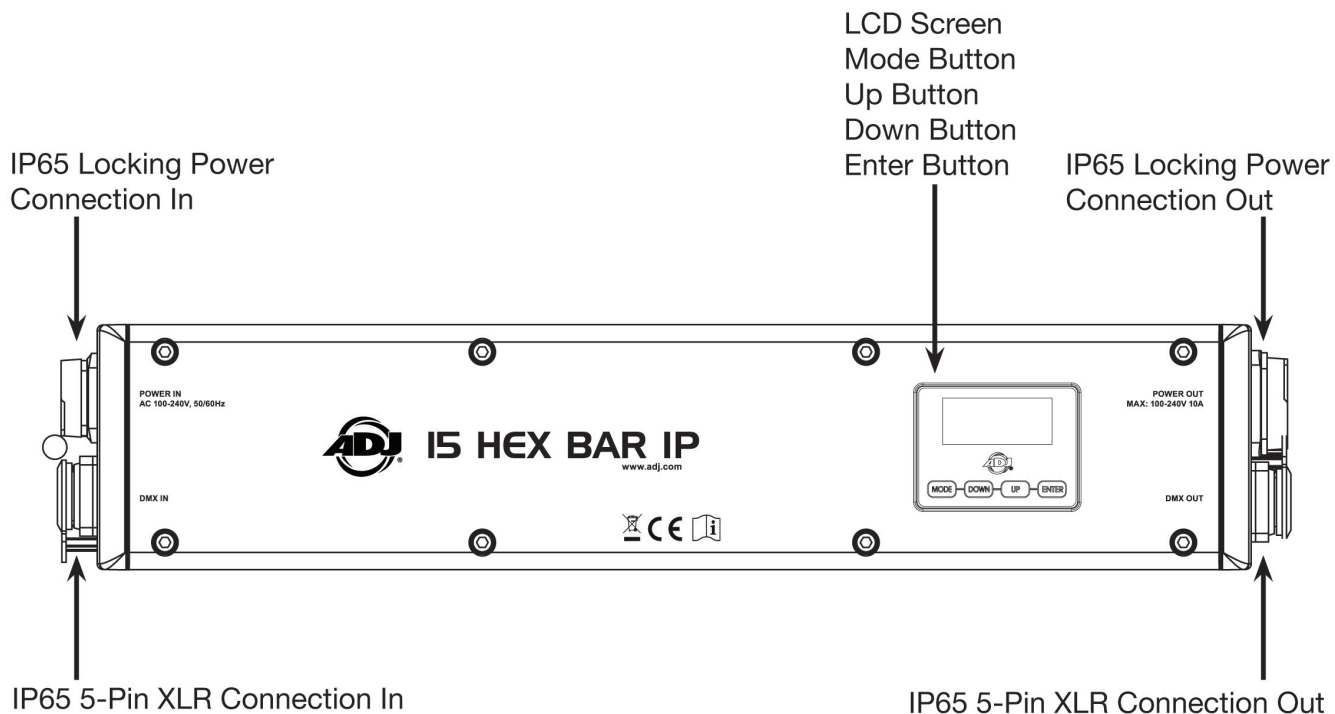

INSTALLATION

Always ensure that the unit is firmly fixed to avoid vibration and slipping while operating. Always ensure that the structure to which you are attaching the unit is secure and is able to support at least 10 times the unit's weight. **ALWAYS** use safety cables that can hold at least 12 times the unit's weight when installing the fixture.

This equipment must be installed by a professional, and it must be installed in a place where it is out of the reach of people's grasp. Overhead mounting requires extensive experience, including calculating working load limits, knowledge of installation material being used, and periodic safety inspection of all installation material and the unit itself. If you lack these qualifications, do not attempt the installation yourself. The installation should be checked by a skilled person once a year.

Ensure ALL connections and end caps are properly sealed with a non-conductive dielectric grease (available at most electrical suppliers) to prevent water ingress/condensation and/or corrosion.

The 15 Hex Bar IP is fully operational in three different mounting positions: hanging upside-down, mounted sideways on trussing, or set on a flat level surface. Be sure this fixture is kept at least 12m (40ft) away from any flammable materials (decoration etc.). **ALWAYS** use and install a properly rated safety cable as a safety measure to prevent accidental damage and/or injury in the event the clamp fails.

Screw one clamp via a M12 screw and nut into the Omega holder. Insert the quick-lock fasteners of the Omega holder into the matching holes of the adjustable mounting bracket. Tighten the quick-lock fasteners fully clockwise. Pull the safety-cable through the attachment openings and over the trussing system or a safe fixation spot. Insert the end in the carabine and tighten the safety screw.

PLEASE REFER TO THE ILLUSTRATIONS ON THE FOLLOWING PAGE.

INSTALLATION

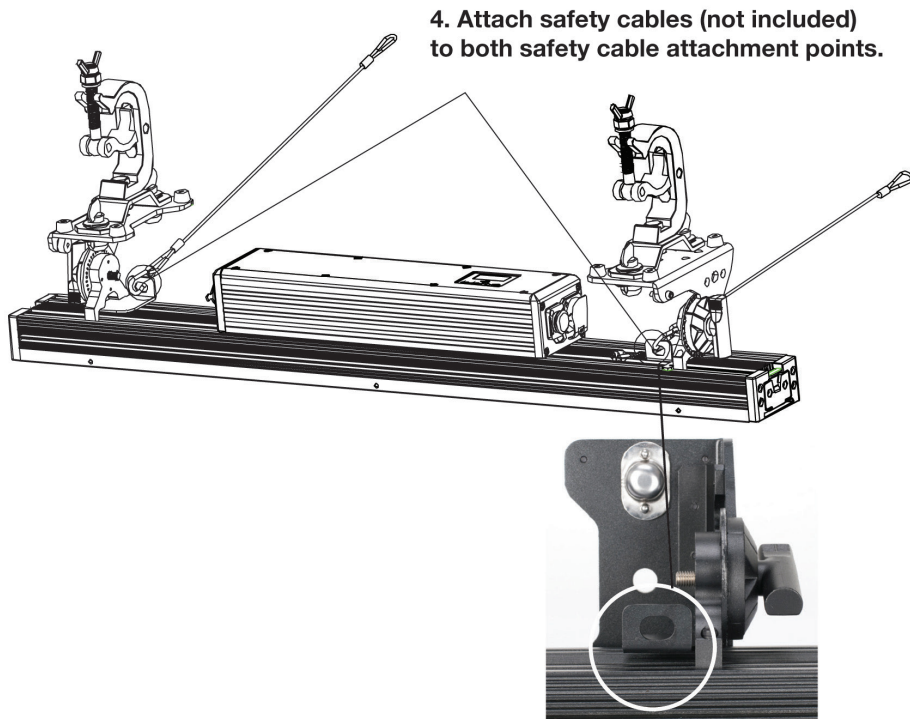
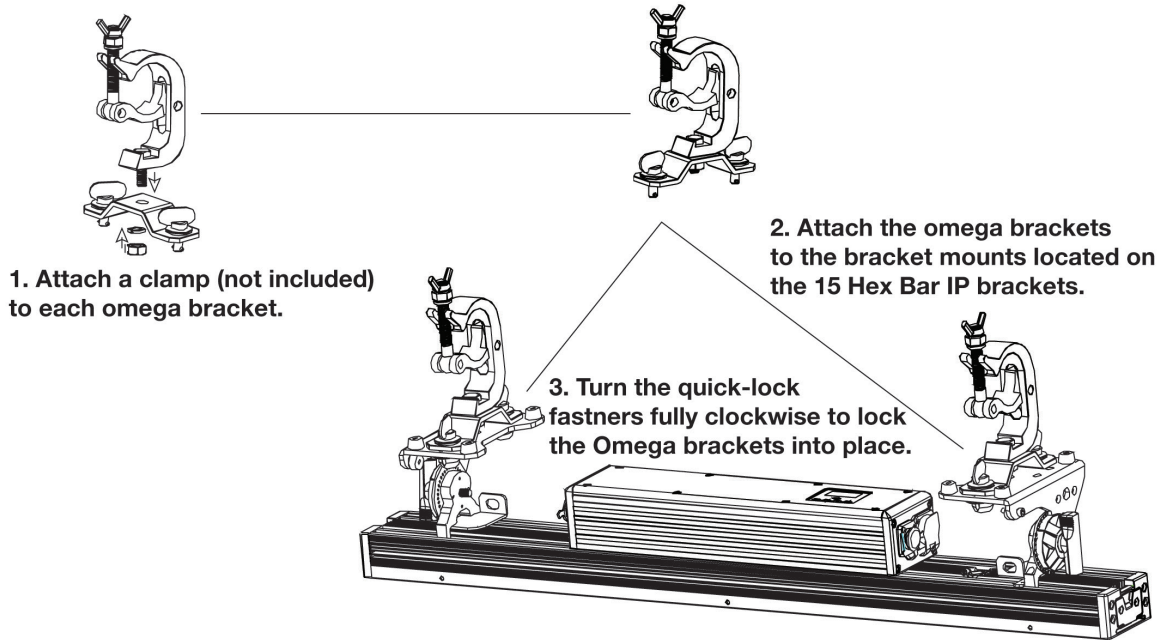

NOTE: Safety cable attachment points are located at both ends. Its recommended to use safety cables on both ends.



ALWAYS ATTACH A SAFETY CABLE WHENEVER INSTALLING THIS DEVICE IN A SUSPENED ENVIRONMENT IN ORDER TO ENSURE THE FIXTURE WILL NOT FALL IF THE CLAMP FAILS.

MANUAL TILT ADJUSTMENT

The bar angle is adjustable manually using the brackets located on each side of the unit. Simply loosen the tilt adjustment knobs attached to each mounting bracket and adjust the bracket accordingly. After making your desired set up, securely tighten the tilt adjustment knobs. The image below illustrates a 90-degree configuration.

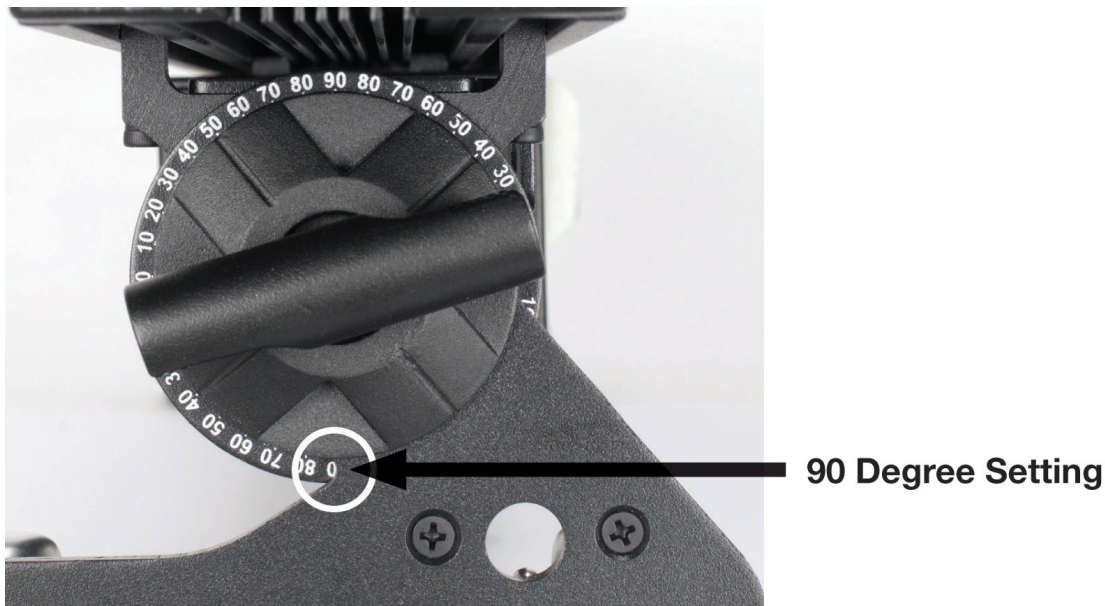

CONNECTIONS

ENSURE ALL CONNECTIONS AND END CAPS ARE PROPERLY SEALED WITH A DIELECTRIC GREASE (AVAILABLE AT MOST ELECTRICAL SUPPLIERS) TO PREVENT WATER CORROSION AND/OR ELECTRICAL SHORT CIRCUIT.

TO MAINTAIN IP65 RATING INTEGRITY AND PREVENT WATER FROM ENTERING THE FIXTURE, ALL CONNECTION RUBBER CAPS MUST BE SEALED WHEN NOT IN USE.



DMX SET UP

DMX-512: DMX is short for Digital Multiplex. This is a universal protocol used as a form of communication between intelligent fixtures and controllers. A DMX controller sends DMX data instructions from the controller to the fixture. DMX data is sent as serial data that travels from fixture to fixture via the DATA “IN” and DATA “OUT” XLR terminals located on all DMX fixtures (most controllers only have a DATA “OUT” terminal).

DMX Linking: DMX is a language allowing all makes and models of different manufacturers to be linked together and operate from a single controller, as long as all fixtures and the controller are DMX compliant. To ensure proper DMX data transmission, try to use the shortest path possible when linking several DMX fixtures. The order in which fixtures are connected in a DMX line does not influence the DMX addressing. For example, a fixture assigned a DMX address of 1 may be placed anywhere in a DMX line: at the beginning, at the end, or anywhere in the middle. When a fixture is assigned a DMX address of 1, the DMX controller knows to send DATA assigned to address 1 to that unit, no matter where it is located in the DMX chain.

Data Cable (DMX Cable) Requirements (For DMX Operation): The 15 Hex Bar IP can be controlled via DMX-512 protocol. The 15 Hex Bar IP has 10 DMX channel modes. The DMX address is set on the back panel of the 15 Hex Bar IP. Your unit and your DMX controller require a standard 5-pin XLR connector for data input and data output. We recommend Accu-Cable DMX cables. If you are making your own cables, be sure to use standard 110-120 Ohm shielded cable (This cable may be purchased at almost all pro lighting stores). Your cables should be made with a male XLR connector at one end and a female XLR connector on the other. Also remember that DMX cable must be daisy chained and cannot be split.

Special Note: Line Termination. When longer runs of cable are used, you may need to use a terminator on the last unit to avoid erratic behavior. A terminator is a 110-120 ohm 1/4 watt resistor which is connected between pins 2 and 3 of a male XLR connector (DATA + and DATA -). This unit is inserted in the female XLR connector of the last unit in your daisy chain to terminate the line. Using a cable terminator (ADJ part number Z-DMX/T) will decrease the possibilities of erratic behavior.

SYSTEM MENU

The fixture includes an easy to navigate system menu control panel display where all necessary settings and adjustments are made. During normal operation, pressing the MENU button once will access the fixture's main menu. Once in the main menu, you can navigate through the different functions and access the sub-menus with the UP and DOWN buttons. When you reach a field that requires adjusting, press the ENTER button to access that field and use the UP and DOWN buttons to adjust the field. Pressing the ENTER button once more will confirm your setting. You may exit the main menu at any time without making any adjustments by pressing the MENU button.

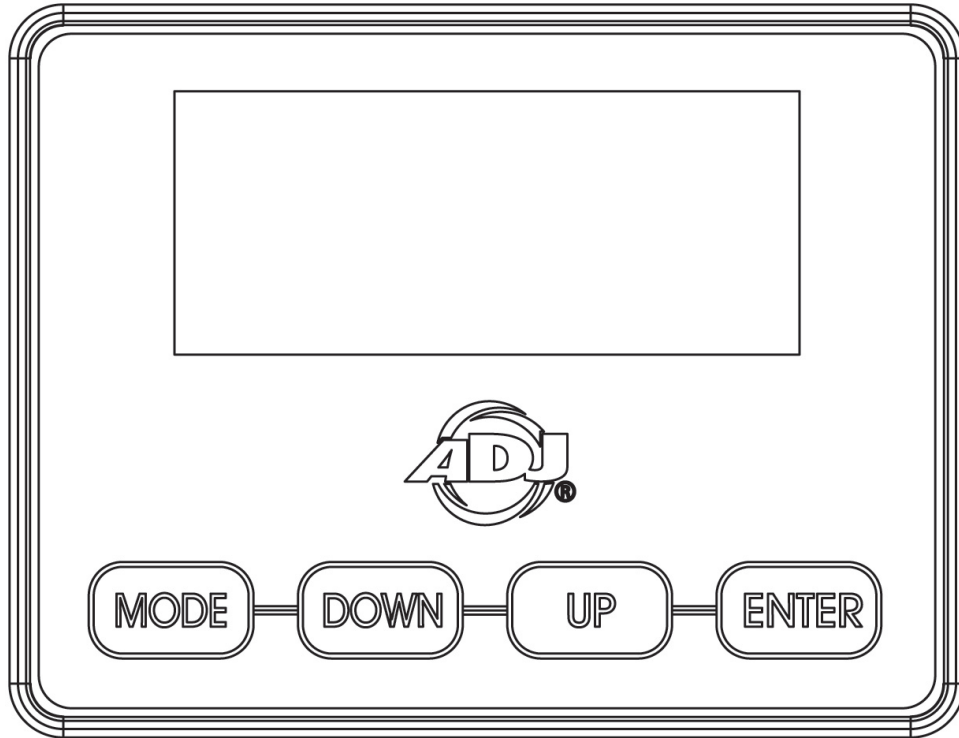

SYSTEM MENU

DMX SET	Address	001 - 512		Set DMX address
	Ch. Mode	6ch		Set DMX mode
		9ch		
		12ch		
		14ch		
		17ch		
		30ch		
		33ch		
		38ch		
		41ch		
	No DMX	60ch		
Hold		Hold last channel values received before DMX signal was lost		
Blackout		Take all channels to 0 when DMX signal is lost		
	Int. Prog.		Run last set internal program when DMX signal is lost	
PERSONALITY	Primary	On / Off		
	Secondary	On / Off		
	Pixel Flip	Off (1-15)		
		On (15-1)		
	Fan Set	Auto		
		High		
		Silent		
	Dim Mode	Standard		
		Stage		
		TV		
		Archi.		
Theatre				
Stage 2				
Dim Speed		0.1 sec - 10 sec		
LED Rfrsh	900~1500 Hz, 6000 Hz, 25000 Hz		Default = 1200 Hz	

CONTINUED ON NEXT PAGE

SYSTEM MENU

PERSONALITY (continued)	Gamma	1.0			
		2.0			
		2.2			
		2.4			
		2.6			
		2.8			
	Display	Save Dlay	1 - 10		
		Lock	Off , 1min - 10min		Time interval of inactivity before screen locks
	Service	Passcode = 011	Calibrat	Red 000 - 255	
				Green 000 - 255	
				Blue 000 - 255	
				White 000 - 255	
				Amber 000 - 255	
UV 000 - 255					
	S. Update	Yes / No			
	Restore	Yes / No		Reset to factory default settings	
MANUAL	Red	000 - 255		Note: Color macros take priority over manual color settings	
	Blue	000 - 255			
	Green	000 - 255			
	White	000 - 255			
	Amber	000 - 255			
	UV	000 - 255			
	Strobe	000 - 255			
	Mastr Dim	000 - 255			
	Clr Macro	00 - 63			
	Clr Temp	000 - 255			
INT PROGS	Prog 0	Speed	000 - 255		
		Fade	000 - 255		
		Sound	On / Off	000 - 255	
	Prog 1	Speed	000 - 255		
		Fade	000 - 255		
		Sound	On / Off	000 - 255	
	
	Prog 13	Sped	000 - 255		
		Fade	000 - 255		
Sound		On / Off	000 - 255		

CONTINUED ON NEXT PAGE

SYSTEM MENU

INFO	Hours	Pwr On Hr 1	xxxxxx Hours		Total hours fixture has been powered on. Non resettable
		Pwr On Hr 2	xxxxxx Hours		Hours fixture has been powered on since last reset
		Pwr On Rst	Passcode = 050		Allows Pwr On Hr 2 to be reset to zero
	Temp	xxx°	F / C		Select units
		Max Temp 1	xxx F / xxx C		Current max temperature since last reset
		Max Temp 2	xxx F / xxx C		All time max temperature, cannot be reset
		Temp Rst	Yes / No	Passcode = 050	Reset Max Temp 2 to zero
	Humidity	Head Humd	xxx %		Humidity in the head
		Base Humd	xxx %		Humidity in the base
	Fan Info	Fan 1 RPM	xxxx		
		Fan 2 RPM	xxxx		
	DMX Value	Red			
		Green			
		...			
		Gamma			
	Soft Vers	x.xx			Current software version

PRIMARY-SECONDARY SET UP

This function allows you to link units together to run in a Primary-Secondary set-up, in which one unit will act as the controlling unit and the others will react to the controlling unit's built-in programs. Any unit can be configured to act as a Primary or as a Secondary, but only one unit in a given system can be programmed to act as the Primary.

Primary-Secondary Connections and Settings:

1. Daisy chain your units via the XLR connectors on the rear panels of each unit. Use standard XLR data cables to link your units together. Remember that the male XLR connector is the input and the female XLR connector is the output. The first unit in the chain (primary) will use the female XLR connector only. The last unit in the chain will use the male XLR connector only.
2. Use the display screen and control panel to navigate to the Personality menu, where you will find both a Primary and Secondary option. If you want the unit to operate as the Primary unit, select Primary and switch it to ON, then select Secondary and switch it to OFF. On the other hand, if you want the unit to operate as a Secondary, select Primary and switch it to OFF, then select Secondary and switch it to ON.
3. Repeat this process until all the connected units have been assigned a Primary or Secondary status. Make sure that only one unit is designated as the Primary, while all other units are designated as Secondaries.
4. The secondary units will act in conjunction with the primary unit.

FAN MODES AND LOW NOISE OPERATION

This unit is a high-performance fixture suited for multiple applications. For noise critical environments such as Theater, Opera or Orchestra Halls, it offers various fan operation modes which remove any distraction for the audience and performers. Fan Modes can be changed remotely via the DMX control channel, allowing the fixture to offer high output or whisper silent operation at a moment's notice. All Fan Modes smoothly transition over a brief time, preventing unwanted attraction to the fixture.

Mode	dbA at 1m LED off	dbA at 1m Dimmer 100%
Fan Control - Auto (Default)	39	46
Fan Control - Silent	32	33
Fan Control - High	50	59

Auto (Default)—Fans only run at the speeds needed to keep the LED engine within a safe temperature range and ensures optimal performance of the fixture. If possible, they will turn-off, for example, when the fixture is dimmed to a low intensity. Fans sense the ambient and fixture temperature, and will always try to keep noise levels to a minimum. The fixture output will only reduce when the LED engine cannot be cooled down to its safe operating range due to high ambient temperature.

NOTE: Recommended for daily operation.

High—Fan speeds are increased throughout for the most efficient cooling of the fixture. This mode will increase wear on the fans and should only be utilized in exceptional circumstances. Fans will always run, even if the fixture is dimmed down. Fixture output is kept at 100% unless the LED engine temperature reaches an unsafe temperature at which point the fixture will reduce power carefully to ensure continued safe operation. This mode is only required in very high ambient temperatures when automatic fan speed adjustments are not desired.

Silent—For very critical noise environments, the fixture offers two additional Low Noise Modes for silent operation. The fixture output will be reduced, however due to the extremely high luminous flux the fixture still offers outstanding performance. In Low Noise Modes all parameters of the fixture operate quieter with reduced fan speeds.

Almost all fixture fans are turned off, and only run when necessary. The fixture LED power output is reduced to 50%.

DMX ADDRESSING

All fixtures should be given a DMX starting address when using a DMX controller, so the correct fixture responds to the correct control signal. This digital starting address is the channel number from which the fixture starts to “listen” to the digital control signal sent out from the DMX controller. The assignment of this starting DMX address is achieved by setting the correct DMX address on the digital control display on the fixture.

You can set the same starting address for all fixtures or a group of fixtures, or set different addresses for each individual fixture. Setting all fixtures to the same DMX address will cause all fixtures to react in the same way; in other words, changing the settings of one channel will affect all the fixtures simultaneously.

If you set each fixture to a different DMX address, each unit will start to “listen” to the channel number you have set, based on the quantity of DMX channels of each fixture. That means changing the settings of one channel will only affect the selected fixture.

For instance, when operating this device in 6 channel mode, you should set the starting DMX address of the first unit to 1, the second unit to 7 (1 + 6), the third unit to 13 (1 + 6 + 6), and so on. See the chart below for more details.

CHANNEL MODE	UNIT 1 ADDRESS	UNIT 2 ADDRESS	UNIT 3 ADDRESS	UNIT 4 ADDRESS
6 Channels	1	7	13	19
9 Channels	1	10	19	28
12 Channels	1	13	25	37
14 Channels	1	15	29	43
17 Channels	1	18	35	52
30 Channels	1	31	61	91
33 Channels	1	34	67	100
38 Channels	1	39	77	115
41 Channels	1	42	83	124
60 Channels	1	61	121	181

DMX TRAITS

CHANNEL										DMX VALUES	FUNCTION
6CH	9CH	12CH	14CH	17CH	30CH	33CH	38CH	41CH	60CH		
1	1	1	1	1						000 - 255	All Red, 0% to 100%
		2								000 - 255	All Red Fine
2	2	3	2	2						000 - 255	All Green, 0 % to 100%
		4								000 - 255	All Green Fine
3	3	5	3	3						000 - 255	All Blue, 0% to 100%
		6								000 - 255	All Blue Fine
4	4	7	4	4						000 - 255	All White, 0% to 100%
		8								000 - 255	All White Fine
5	5	9	5	5						000 - 255	All Amber, 0% to 100%
		10								000 - 255	All Amber Fine
6	6	11	6	6						000 - 255	All UV, 0% to 100%
		12								000 - 255	All UV Fine
					1	1	1	1	1	000 - 255	Red 1, 0% to 100%
									2	000 - 255	Red 1 Fine
					2	2	2	2	3	000 - 255	Green 1, 0% to 100%
									4	000 - 255	Green 1 Fine
					3	3	3	3	5	000 - 255	Blue 1, 0% to 100%
									6	000 - 255	Blue 1 Fine
					4	4	4	4	7	000 - 255	White 1, 0% to 100%
									8	000 - 255	White 1 Fine
					5	5	5	5	9	000 - 255	Amber 1, 0% to 100%
									10	000 - 255	Amber 1 Fine
					6	6	6	6	11	000 - 255	UV 1, 0% to 100%
									12	000 - 255	UV 1 Fine
					7	7	7	7	13	000 - 255	Red 2, 0% to 100%
									14	000 - 255	Red 2 Fine
					8	8	8	8	15	000 - 255	Green 2, 0% to 100%
									16	000 - 255	Green 2 Fine
					9	9	9	9	17	000 - 255	Blue 2, 0% to 100%
									18	000 - 255	Blue 2 Fine
					10	10	10	10	19	000 - 255	White 2, 0% to 100%
									20	000 - 255	White 2 Fine
					11	11	11	11	21	000 - 255	Amber 2, 0% to 100%
									22	000 - 255	Amber 2 Fine
					12	12	12	12	23	000 - 255	UV 2, 0% to 100%

CONTINUED ON NEXT PAGE

DMX TRAITS

CHANNEL										DMX VALUES	FUNCTION
6CH	9CH	12CH	14CH	17CH	30CH	33CH	38CH	41CH	60CH		
									24	000 - 255	UV 2 Fine
					13	13	13	13	25	000 - 255	Red 3, 0% to 100%
									26	000 - 255	Red 3 Fine
					14	14	14	14	27	000 - 255	Green 3, 0% to 100%
									28	000 - 255	Green 3 Fine
					15	15	15	15	29	000 - 255	Blue 3, 0% to 100%
									30	000 - 255	Blue 3 Fine
					16	16	16	16	31	000 - 255	White 3, 0% to 100%
									32	000 - 255	White 3 Fine
					17	17	17	17	33	000 - 255	Amber 3, 0% to 100%
									34	000 - 255	Amber 3 Fine
					18	18	18	18	35	000 - 255	UV 3, 0% to 100%
									36	000 - 255	UV 3 Fine
					19	19	19	19	37	000 - 255	Red 4, 0% to 100%
									38	000 - 255	Red 4 Fine
					20	20	20	20	39	000 - 255	Green 4, 0% to 100%
									40	000 - 255	Green 4 Fine
					21	21	21	21	41	000 - 255	Blue 4, 0% to 100%
									42	000 - 255	Blue 4 Fine
					22	22	22	22	43	000 - 255	White 4, 0% to 100%
									44	000 - 255	White 4 Fine
					23	23	23	23	45	000 - 255	Amber 4, 0% to 100%
									46	000 - 255	Amber 4 Fine
					24	24	24	24	47	000 - 255	UV 4, 0% to 100%
									48	000 - 255	UV 4 Fine
					25	25	25	25	49	000 - 255	Red 5, 0% to 100%
									50	000 - 255	Red 5 Fine
					26	26	26	26	51	000 - 255	Green 5, 0% to 100%
									52	000 - 255	Green 5 Fine
					27	27	27	27	53	000 - 255	Blue 5, 0% to 100%
									54	000 - 255	Blue 5 Fine
					28	28	28	28	55	000 - 255	White 5, 0% to 100%
									56	000 - 255	White 5 Fine
					29	29	29	29	57	000 - 255	Amber 5, 0% to 100%
									58	000 - 255	Amber 5 Fine

CONTINUED ON NEXT PAGE

DMX TRAITS

CHANNEL										DMX VALUES	FUNCTION
6CH	9CH	12CH	14CH	17CH	30CH	33CH	38CH	41CH	60CH		
					30	30	30	30	59	000 - 255	UV 5 , 0% to 100%
									60	000 - 255	UV 5 Fine
			7	7			31	31		000 - 255	Color Macros , see Color Macros Chart section of this manual
			8	8			32	32		000 - 255	Color Temperature , 2700K - 7000K Linear
											Shutter, Strobe
										000 - 031	LEDs Off
										032 - 063	LEDs On
										064 - 095	Strobe Effect, slow to fast
	7		9	9		31	33	33		096 - 127	LEDs On
										128 - 159	Pulse Effect in Sequences
										160 - 191	LEDs On
										192 - 223	Random Strobe Effect, slow to fast
										224 - 255	LEDs On
	8		10	10		32	34	34		000 - 255	Dimmer Intensity , 0% to 100%
	9		11	11		33	35	35		000 - 255	Dimmer Fine
											Auto Programs
										000 - 010	Off
										011 - 026	Auto Program 1
										027 - 043	Auto Program 2
										044 - 060	Auto Program 3
										061 - 076	Auto Program 4
										077 - 093	Auto Program 5
				12				36		094 - 110	Auto Program 6
										111 - 126	Auto Program 7
										127 - 143	Auto Program 8
										144 - 160	Auto Program 9
										161 - 176	Auto Program 10
										177 - 193	Auto Program 11
										194 - 210	Auto Program 12
										211 - 226	Auto Program 13
										227 - 255	No Function

CONTINUED ON NEXT PAGE

DMX TRAITS

CHANNEL										DMX VALUES	FUNCTION
6CH	9CH	12CH	14CH	17CH	30CH	33CH	38CH	41CH	60CH		
				13				37		000 - 255	Auto Programs Speed , slow to fast
				14				38		000 - 255	Auto Programs Fade , least fade to most fade
											Dim Mode
										000 - 020	Standard
										021 - 040	Stage
										041 - 060	TV
										061 - 080	Architectural
										081 - 100	Theatre
										101 - 120	Stage 2
										121	0.1 sec
										122	0.2 sec
										123	0.3 sec
										124	0.4 sec
										125	0.5 sec
										126	0.6 sec
			12	15			36	39		127	0.7 sec
										128	0.8 sec
										129	0.9 sec
										130	1.0 sec
										131	1.5 sec
										132	2.0 sec
										133	3.0 sec
										134	4.0 sec
										135	5.0 sec
										136	6.0 sec
										137	7.0 sec
										138	8.0 sec
										139	9.0 sec
										140	10.0 sec
										141 - 255	Default to unit setting
											Refresh Rates
			13	16			37	40		000 - 015	Default to unit setting
										016 - 030	900 Hz
										031 - 045	1000 Hz

CONTINUED ON NEXT PAGE

DMX TRAITS

CHANNEL										DMX VALUES	FUNCTION
6CH	9CH	12CH	14CH	17CH	30CH	33CH	38CH	41CH	60CH		
			13	16			37	40			Refresh Rates (continued)
											046 - 060 1100 Hz
											061 - 075 1200 Hz
											076 - 090 1300 Hz
											091 - 105 1400 Hz
											106 - 120 1500 Hz
											121 - 135 2500 Hz
											136 - 150 4000 Hz
											151 - 165 5000 Hz
											166 - 180 10000 Hz
											181 - 195 15000 Hz
											196 - 210 20000 Hz
											211 - 225 25000 Hz
											226 - 255 No Function
			14	17			38	41			Gamma
											000 - 020 Default to unit setting
											021 - 040 2.0
											041 - 060 2.2
											061 - 080 2.4
											081 - 100 2.6
											101 - 120 2.8
											121 - 255 No function

COLOR MACRO CHART

COLOR NUMBER	DMX VALUE	COLOR INTENSITY					
		RED	GREEN	BLUE	WHITE	AMBER	UV
Off	000	0	0	0	0	0	0
Color1	001 - 004	80	255	234	80	0	0
Color2	005 - 008	80	255	164	80	0	0
Color3	009 - 012	77	255	112	77	0	0
Color4	013 - 016	117	255	83	83	0	0
Color5	017 - 020	160	255	77	77	0	0
Color6	021 - 024	223	255	83	83	0	0
Color7	025 - 028	255	243	77	77	0	0
Color8	029 - 032	255	200	74	74	0	0
Color9	033 - 036	255	166	77	77	0	0
Color10	037 - 040	255	125	74	74	0	0
Color11	041 - 044	255	97	77	74	0	0
Color12	045 - 048	255	71	77	71	0	0
Color13	049 - 052	255	83	134	83	0	0
Color14	053 - 056	255	93	182	93	0	0
Color15	057 - 060	255	96	236	96	0	0
Color16	061 - 064	238	93	255	93	0	0
Color17	065 - 068	196	87	255	87	0	0
Color18	069 - 072	150	90	255	90	0	0
Color19	073 - 076	100	77	255	77	0	0
Color20	077 - 080	77	100	255	77	0	0
Color21	081 - 084	67	148	255	67	0	0
Color22	085 - 088	77	195	255	77	0	0
Color23	089 - 092	77	234	255	77	0	0
Color24	093 - 096	158	255	144	144	0	0
Color25	097 - 100	255	251	153	153	0	0
Color26	101 - 104	255	175	147	147	0	0
Color27	105 - 108	255	138	186	138	0	0
Color28	109 - 112	255	147	251	147	0	0
Color29	113 - 116	151	138	255	138	0	0
Color30	117 - 120	100	138	255	138	0	0
Color31	121 - 124	138	169	255	138	0	0
Color32	125 - 128	255	255	255	255	0	0
Color33	129 - 132	255	206	143	0	0	0

CONTINUED ON NEXT PAGE

COLOR MACRO CHART

COLOR NUMBER	DMX VALUES	COLOR INTENSITY					
		RED	GREEN	BLUE	WHITE	AMBER	UV
Color34	133 - 136	254	177	153	0	0	0
Color35	137 - 140	254	192	138	0	0	0
Color36	141 - 144	254	165	98	0	0	0
Color37	145 - 148	254	121	0	0	0	0
Color38	149 - 152	176	17	0	0	0	0
Color39	153 - 156	96	0	11	0	0	0
Color40	157 - 160	234	139	171	0	0	0
Color41	161 - 164	224	5	97	0	0	0
Color42	165 - 168	175	77	173	0	0	0
Color43	169 - 172	119	130	199	0	0	0
Color44	173 - 176	147	164	212	0	0	0
Color45	177 - 180	88	2	163	0	0	0
Color46	181 - 184	0	38	86	0	0	0
Color47	185 - 188	0	142	208	0	0	0
Color48	189 - 192	52	148	209	0	0	0
Color49	193 - 196	0	46	35	0	0	0
Color50	197 - 200	8	107	222	0	0	0
Color51	201 - 204	107	156	231	0	0	0
Color52	205 - 208	165	198	247	0	0	0
Color53	209 - 212	0	83	115	0	0	0
Color54	213 - 216	0	97	166	0	0	0
Color55	217 - 220	1	100	167	0	0	0
Color56	221 - 224	0	40	86	0	0	0
Color57	225 - 228	209	219	182	0	0	0
Color58	229 - 232	42	165	85	0	0	0
Color59	233 - 236	255	0	0	0	0	0
Color60	237 - 240	0	255	0	0	0	0
Color61	241 - 244	0	0	255	0	0	0
Color62	245 - 248	0	0	0	255	0	0
Color63	249 - 252	0	0	0	0	255	0
Color64	253 - 255	0	0	0	0	0	255

PIXEL ZONES

PIXEL FLIP OFF

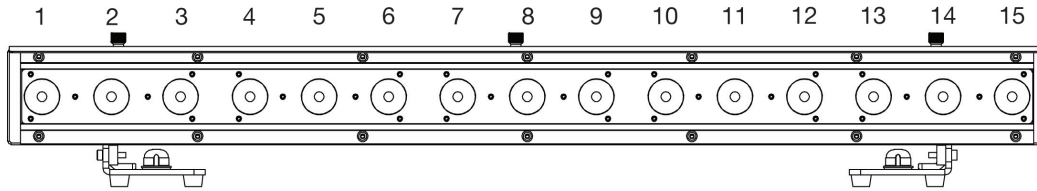

PIXEL FLIP ON

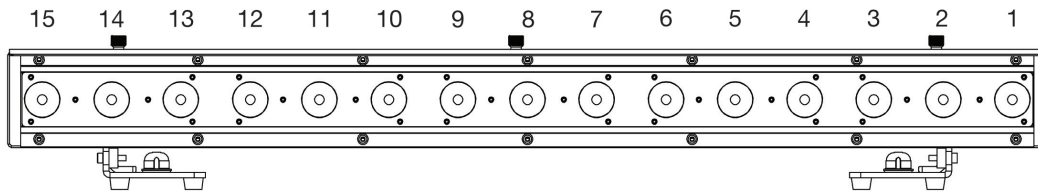

DIMMER CURVE CHART

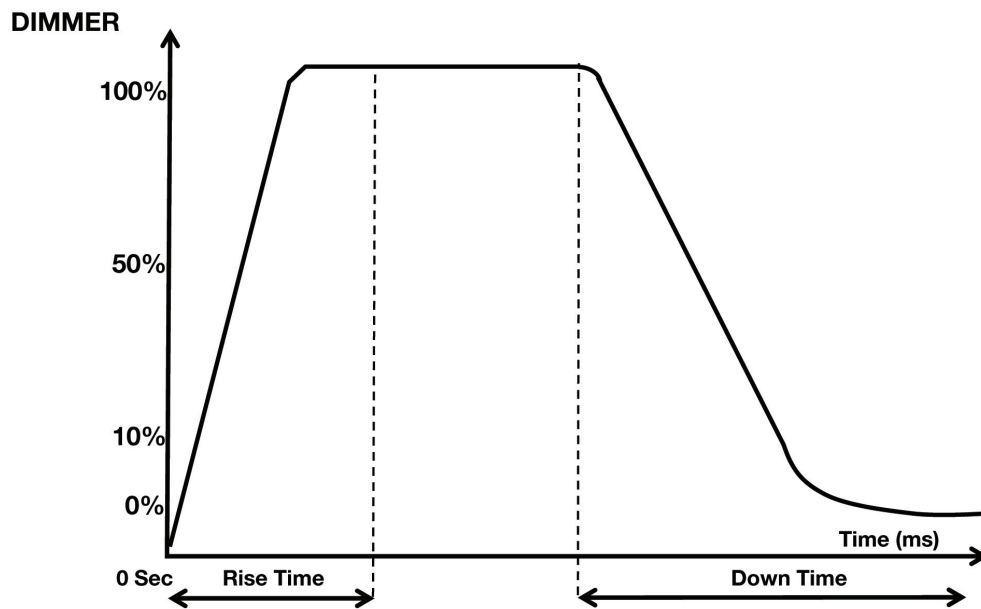

Dimming Curve Ramp Effect	0 sec Fade Time		1 sec Fade Time	
	Rise Time (ms)	Down Time (ms)	Rise Time (ms)	Down Time (ms)
Standard (default)	0	0	0	0
Stage	780	1100	1540	1660
TV	1180	1520	1860	1940
Architectural	1380	1730	2040	2120
Theatre	1580	1940	2230	2280
Stage 2	0	1100	0	1660

GLARE SHIELD INSTALLATION

The 15 Hex Bar IP comes with an attachable glare shield. The glare shield can easily be installed by following the directions below. If you have any questions regarding installation, please contact ADJ customer support.

1. Locate the three (3) screw holes located on either side of the unit.

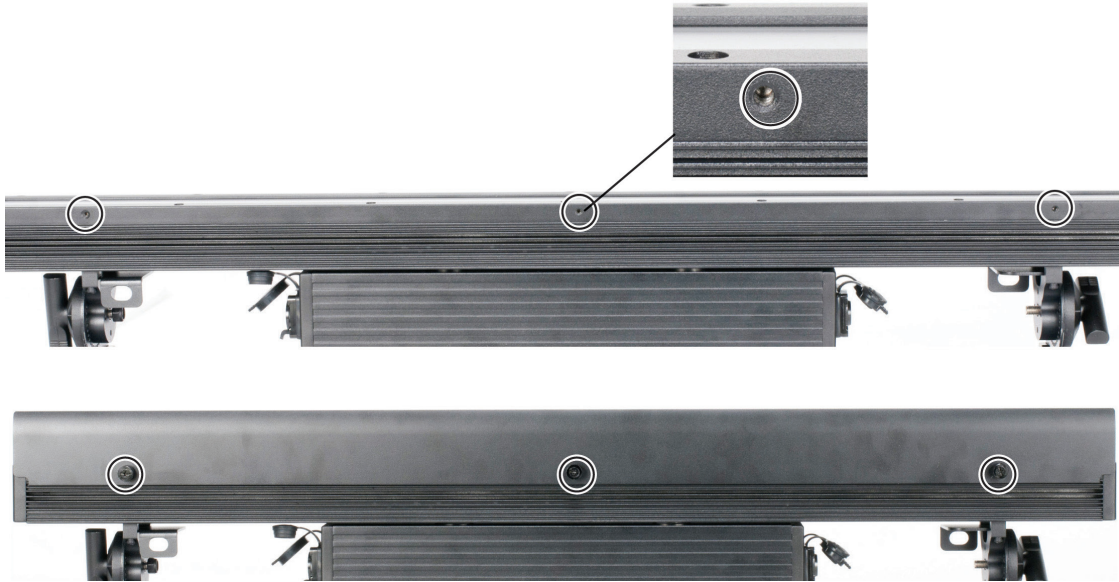

2. Line up the three (3) glare shield thumb screws with the three (3) thumb screw holes located on either side of the unit. Screw the thumb screws in and tighten. DO NOT overtighten.

FILTER INSTALLATION

The 15 Hex Bar IP comes with an optional frost/diffuser filter. The filter can easily be installed by following the directions below. If you have any questions regarding installation, please contact ADJ customer support.



Locate the filter slot door located at either end of the unit. Pull and hold the slot door down and gently slide the frost/diffuser filter in. Make sure the filter is all the way inside before releasing the slot door to close.

DIMENSIONAL DRAWINGS

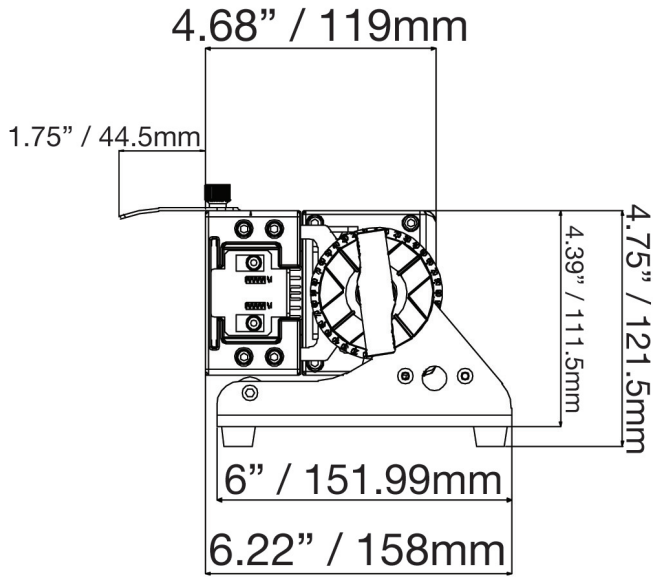

BAR FACING 0°

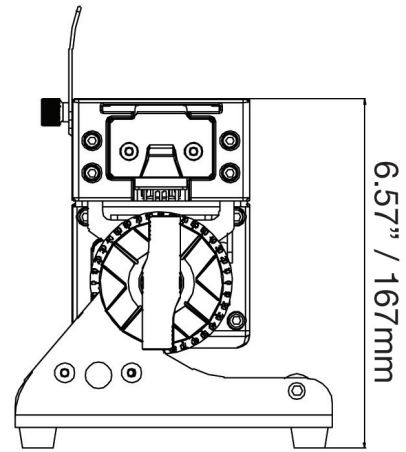

BAR FACING UP (90°)

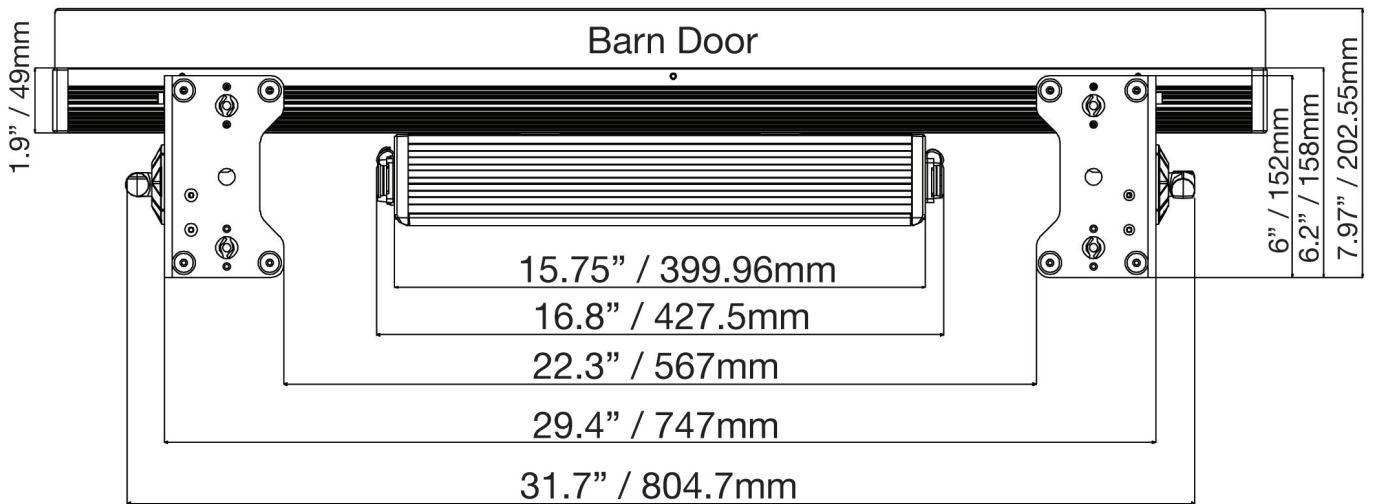
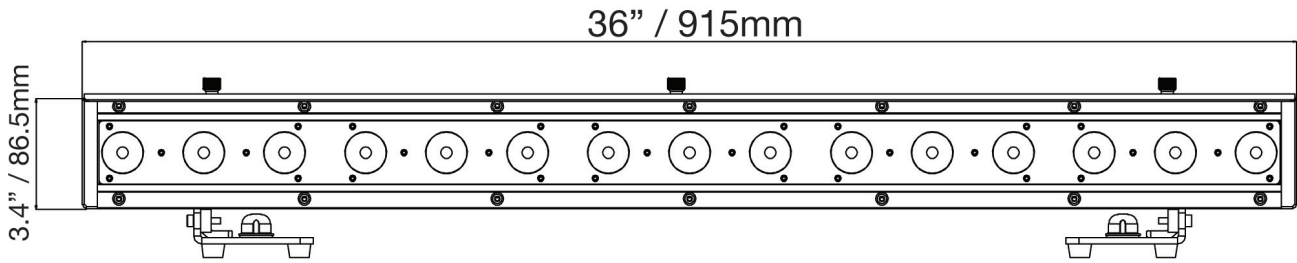

MULTIPLE UNIT POWER LINKING

With this feature you can link the fixtures to one another using the power cable input and output sockets.

The maximum number of units that can be linked in this manner is as follows:

- 6 units with 120V power.
- 15 units with 240V power.

NOTE: USE CAUTION WHEN POWER LINKING OTHER FIXTURES AS THE POWER CONSUMPTION OF OTHER MODEL FIXTURES MAY EXCEED THE MAX POWER OUTPUT ON THIS FIXTURE! CHECK SILK SCREEN FOR MAX AMPS.

TROUBLE SHOOTING

Below is a common problem that the user may encounter, with a potential solution.

Unit not responding to DMX:

Check that the DMX cables are connected and wired properly (pin 3 is “hot”; on some other DMX devices pin 2 may be “hot”). Also, check that all cables are connected to the proper connectors, as the manner in which the input and outputs are connected does have an effect on how the devices operate.

CLEANING

Due to fog residue, smoke, and dust, cleaning the internal and external optical lenses must be carried out periodically to optimize light output.

- Use normal glass cleaner and a soft cloth to wipe down the outside casing.
- Periodically clean the external optics with glass cleaner and a soft cloth.
- Always be sure to dry all parts completely before plugging the unit back in.

Cleaning frequency depends on the environment in which the fixture operates (i.e. smoke, fog residue, dust, dew).

LIMITED WARRANTY (USA ONLY)

- A. ADJ Products, LLC hereby warrants, to the original purchaser, ADJ Products, LLC products to be free of manufacturing defects in material and workmanship for a prescribed period from the date of purchase (see specific warranty period on reverse). This warranty shall be valid only if the product is purchased within the United States of America, including possessions and territories. It is the owner's responsibility to establish the date and place of purchase by acceptable evidence, at the time service is sought.
- B. For warranty service, you must obtain a Return Authorization number (RA#) before sending the product back—please contact ADJ Products, LLC Service Department at 800-322-6337. Send the product only to the ADJ Products, LLC factory. All shipping charges must be prepaid. If the requested repairs or service (including parts replacement) are within the terms of this warranty, ADJ Products, LLC will pay return shipping charges only to a designated point within the United States. If the entire instrument is sent, it must be shipped in its original package and packaging material. No accessories should be shipped with the product. If any accessories are shipped with the product, ADJ Products, LLC shall incur no liability whatsoever for loss of or damage to any such accessories, nor for the safe return thereof.
- C. This warranty is void if the product serial number and/or labels are altered or removed; if the product is modified in any manner which ADJ Products, LLC concludes, after inspection, affects the reliability of the product; if the product has been repaired or serviced by anyone other than the ADJ Products, LLC factory unless prior written authorization was issued to purchaser by ADJ Products, LLC; if the product is damaged because it was not properly maintained as set forth in the product instructions, guidelines and/or user manual.
- D. This is not a service contract, and this warranty does not include maintenance, cleaning, or periodic check-up. During the period specified above, ADJ Products, LLC will replace defective parts at its expense with new or refurbished parts, and will absorb all expenses for warranty service and repair labor by reason of defects in material or workmanship. The sole responsibility of ADJ Products, LLC under this warranty shall be limited to the repair of the product, or replacement thereof, including parts, at the sole discretion of ADJ Products, LLC. All products covered by this warranty were manufactured after August 15, 2012, and bear identifying marks to that effect.
- E. ADJ Products, LLC reserves the right to make changes in design and/or improvements upon its products without any obligation to include these changes in any products theretofore manufactured.
- F. No warranty, whether expressed or implied, is given or made with respect to any accessory supplied with products described above. Except to the extent prohibited by applicable law, all implied warranties made by ADJ Products, LLC in connection with this product, including warranties of merchantability or fitness, are limited in duration to the warranty period set forth above. And all warranties, whether expressed or implied, including warranties of merchantability or fitness, are limited in duration to the warranty period set forth above. The consumer's and/or dealer's sole remedy shall be such repair or replacement as is expressly provided above; and under no circumstances shall ADJ Product, LLC be liable for any loss and/or damage, direct and/or consequential arising out of the use of, and/or inability to use this product.
- G. This warranty is the only written warranty applicable to ADJ Products, LLC products, and supersedes all prior warranties and written descriptions of warranty terms and conditions heretofore published.

MANUFACTURER'S LIMITED WARRANTY PERIODS:

- Non-LED Lighting Products = 1-Year (365 Days) (Including Special Effect Lighting, Intelligent Lighting, UV lighting, Strobes, Fog Machines, Bubble Machines, Mirror Balls, Par Cans, Trussing, Lighting Stands, Power/Data Distribution, etc. excluding LED and lamps)
- Laser Products = 1-Year (365 Days) (excluding laser diodes which have a 6-Month Limited Warranty)
- LED Products = 2-Year (730 Days) (excluding batteries which have a 180 Day Limited Warranty)
- NOTE: 2-Year (730 Days) Limited Warranty ONLY applies to product purchased within the United States.
- StarTec Series = 1-Year (365 Days) (excluding batteries which have a 180 Day Limited Warranty)
- ADJ DMX Controllers = 2 Year (730 Days)
- American Audio Products = 1 Year (365 Days)

SPECIFICATIONS

Light Source:

- LED: 15x 12W HEX (6-In-1) RGBWA+UV LEDs (50,000 hr.)
- Beam Angle: 25-degrees
- LUX: 14541 @ 1M, 582 @ 5M (Full On No UV); 14517 @ 1M, 581 @ 5M (Full On)

Features:

- IP65 rated – protects from dust, sand, moisture and liquid (Temporary outdoor use only)
- All metal construction with black housing
- Includes heavy duty bracket
- Sure-lock locking bracket system (securely locks every 10-degrees)
- Flicker free for film and broadcast
- 63 Built-in Color Macros
- Linear variable white temperature control

Construction:

- Display: OLED display with function buttons
- Data In/Out: Seetronic IP65 rated, 5-pin DMX In/Out (with rubber protective covers over connections)
- Power In/Out: Seetronic IP65 rated Power locking In/Out (with rubber protective covers over connections)
- Daisy chain up to 6 fixtures @ 120V; 15 fixtures @ 240V
- All Metal Heavy-Duty Housing: Built To Last In Outdoor or Touring Applications

Control:

- Multiple DMX channel modes
- Built-in internal programs
- 5 individually controlled sections with Zone Control
- 0-100% Dimming + smooth 16-bit Dimming
- 6 Dimming Curve Modes• Control Mode: DMX512, RDM (Remote Device Management)
- With Wired Digital Communication Network

Electrical:

- Power voltage: AC100-240V, 50/60Hz (Multi-voltage)
- Power consumption: 130W max

Dimensions & Weight:

- Dimension (LxWxH): 36" x 8" x 7.75" / 915x203x200mm
- Weight: 20 lbs. / 8.9 kg.

Approvals / Rating:

- CE Certified / IP65 (Temporary outdoor use only)

Please Note: Specifications and improvements in the design of this unit and this manual are subject to change without any prior written notice.

