

# **HYDRO BEAM X2**

User Instructions

©2022 ADJ Products, LLC all rights reserved. Information, specifications, diagrams, images, and instructions herein are subject to change without notice. ADJ Products, LLC logo and identifying product names and numbers herein are trademarks of ADJ Products, LLC. Copyright protection claimed includes all forms and matters of copyrightable materials and information now allowed by statutory or judicial law or hereinafter granted. Product names used in this document may be trademarks or registered trademarks of their respective companies and are hereby acknowledged. All non-ADJ Products, LLC brands and product names are trademarks or registered trademarks of their respective companies.

**ADJ Products, LLC** and all affiliated companies hereby disclaim any and all liabilities for property, equipment, building, and electrical damages, injuries to any persons, and direct or indirect economic loss associated with the use or reliance of any information contained within this document, and/or as a result of the improper, unsafe, insufficient and negligent assembly, installation, rigging, and operation of this product.

**ADJ PRODUCTS LLC World Headquarters**

6122 S. Eastern Ave. | Los Angeles, CA 90040 USA

Tel: 800-322-6337 | Fax: 323-582-2941 | [www.adj.com](http://www.adj.com) | [lsupport@adj.com](mailto:lsupport@adj.com)

**ADJ Supply Europe B.V.**

Junostraat 2 | 6468 EW Kerkrade | Netherlands

Tel: +31 45 546 85 00 | Fax: +31 45 546 85 99 | [www.americandj.eu](http://www.americandj.eu) | [service@americandj.eu](mailto:service@americandj.eu)

Europe Energy Saving Notice

Energy Saving Matters (EuP 2009/125/EC)

Saving electric energy is a key to help protecting the environment. Please turn off all electrical products when they are not in use. To avoid power consumption in idle mode, disconnect all electrical equipment from power when not in use. Thank you!

**DOCUMENT VERSION**



Due to additional product features and/or enhancements, an updated version of this document may be available online.

Please check [www.adj.com](http://www.adj.com) for the latest revision/update of this manual before beginning installation and/or programming.

Date	Document Version	Software Version >	DMX Channel Mode	Notes
07/02/19	1	1.0.2	16 / 17	Initial Version
09/26/19	1.2	N/C	N/C	3-Pin DMX Updated to 5-Pin
10/31/19	2	1.0.4	N/C	“Reset All” Added to DMX Modes Pan Degree Selection Added Gamma Removed, Dimming Curves Added
05/06/21	3.5	N/C	N/C	Updated Dimensions
07/20/21	4.0	N/C	N/C	Updated Antenna Range
08/10/21	4.5	N/C	N/C	Updated WiFly Control
12/01/22	5.0	N/C	N/C	Updated IP65 Notice and Torque Settings for Screws; added RDM
12/05/22	5.5	N/C	N/C	Removed FCC Statement

# CONTENTS

General Information	4
Limited Warranty (USA Only)	5
IP65 Notice	6
Safety Guidelines	7
Overview	11
Discharge Lamp Warning	12
Lamp Installation	13
Torque Settings for Screws	15
Gobo Specifications   Gobos	17
Gobo Installation	18
Fixture Installation	22
Connections	25
Remote Device Management (RDM)	26
DMX Set Up	27
DMX Addressing	28
System Menu	29
WiFly Control	35
DMX Traits: Channel Functions & Values	36
Error Codes	39
Multiple Power Linking   Cleaning	41
Specifications	42
Dimensions	43

# **GENERAL INFORMATION**

## **INTRODUCTION**

Please read and understand all instructions in this manual carefully and thoroughly before attempting to operate these products. These instructions contain important safety and use information.

## **UNPACKING**

The products in this kit have been thoroughly tested and have been shipped in perfect operating condition. Carefully check the shipping carton for damage that may have occurred during shipping. If the carton appears to be damaged, carefully inspect each unit included for damage and be sure all accessories necessary to operate the units have arrived intact. In the event damage has been found or parts are missing, please contact our customer support team for further instructions. Please do not return this kit to your dealer without first contacting customer support at the number listed below. Please do not discard the shipping carton in the trash. Please recycle whenever possible.

## **WARRANTY RETURNS**

All returned service items whether under warranty or not, must be freight pre-paid and accompany a return authorization (R.A.) number. The R.A. number must be clearly written on the outside of the return package. A brief description of the problem as well as the R.A. number must also be written down on a piece of paper and included in the shipping container. If the unit is under warranty, you must provide a copy of your proof of purchase invoice. Items returned without a R.A. number clearly marked on the outside of the package will be refused and returned at customer's expense. You may obtain a R.A. number by contacting customer support.

## LIMITED WARRANTY (USA ONLY)

- A. ADJ Products, LLC hereby warrants, to the original purchaser, ADJ Products, LLC products to be free of manufacturing defects in material and workmanship for a prescribed period from the date of purchase (see specific warranty period on reverse). This warranty shall be valid only if the product is purchased within the United States of America, including possessions and territories. It is the owner's responsibility to establish the date and place of purchase by acceptable evidence, at the time service is sought.
- B. For warranty service, you must obtain a Return Authorization number (RA#) before sending back the product-please contact ADJ Products, LLC Service Department at 800-322-6337. Send the product only to the ADJ Products, LLC factory. All shipping charges must be pre-paid. If the requested repairs or service (including parts replacement) are within the terms of this warranty, ADJ Products, LLC will pay return shipping charges only to a designated point within the United States. If the entire instrument is sent, it must be shipped in its original package. No accessories should be shipped with the product. If any accessories are shipped with the product, ADJ Products, LLC shall have no liability whatsoever for loss of or damage to any such accessories, or for the safe return thereof.
- C. This warranty is void if the serial number has been altered or removed; if the product is modified in any manner which ADJ Products, LLC concludes, after inspection, affects the reliability of the product, if the product has been repaired or service by anyone other than ADJ Products, LLC factory unless prior written authorization was issued to purchaser by ADJ Products, LLC; if the product is damaged because not properly maintained as set forth in the instruction manual.
- D. This is not a service contract, and this warranty does not include maintenance, cleaning or periodic check up. During the period specified above, ADJ Products, LLC will replace defective parts at its expense with new or refurbished parts, and will absorb all expenses for warranty service and repair labor by reason of defects in material or workmanship. The sole responsibility of ADJ Products, LLC under this warranty shall be limited to the repair of the product, or replacement thereof, including parts, at the sole discretion of ADJ Products, LLC. All products covered by this warranty were manufactured after August 15, 2012, and bear identifying marks to that effect.
- E. ADJ Products, LLC reserves the right to make changes in design and/or improvements upon its products without any obligation to include these changes in any products theretofore manufactured.
- F. No warranty, whether expressed or implied, is given or made with respect to any accessory supplied with products described above. Except to the extent prohibited by applicable law, all implied warranties made by ADJ Products, LLC in connection with this product, including warranties of merchantability or fitness, are limited in duration to the warranty period set forth above. And no warranties, whether expressed or implied, including warranties of merchantability or fitness, shall apply to this product after said period has expired. The consumer's and/or Dealer's sole remedy shall be such repair or replacement as is expressly provided above; and under no circumstances shall ADJ Products, LLC be liable for any loss or damage, direct or consequential, arising out of the use of, or inability to use, this product.
- G. This warranty is the only written warranty applicable to ADJ Products, LLC Products and supersedes all prior warranties and written descriptions of warranty terms and conditions heretofore published.

### LIMITED WARRANTY PERIODS

- **Non L.E.D. Lighting Products = 1-year (365 days) Limited Warranty** (Such as: Special Effect Lighting, Intelligent Lighting, UV lighting, Strobes, Fog Machines, Bubble Machines, Mirror Balls, Par Cans, Trussing, Lighting Stands etc. excluding LED and lamps)
- **Laser Products = 1 Year (365 Days) Limited Warranty** (excludes laser diodes which have 6 month limited warranty)
- **L.E.D. Products = 2-year (730 days) Limited Warranty** (excluding batteries which have a 180 day limited warranty)  
Note: 2 Year Warranty only applies to purchases within the United States.
- **StarTec Series = 1 Year Limited Warranty** (excluding batteries which have a 180 day limited warranty)
- **ADJ DMX Controllers = 2 Year (730 Days) Limited Warranty**

## IP65 NOTICE

An IP rated lighting fixture is one, which is commonly installed in outdoor environments and has been designed with an enclosure that effectively protects the ingress (entry) of external foreign objects such as dust and water. The International Protection (IP) rating system is commonly expressed as “IP” (Ingress Protection) followed by two numbers (i.e. IP65) where the numbers define the degree of protection. The first digit (Foreign Bodies Protection) indicates the extent of protection against particles entering the fixture and the second digit (Water Protection) indicates the extent of protection against water entering the fixture. An IP65 rated lighting fixture has been designed and tested to protect against the ingress of dust (6) and low-pressure water jets from any direction (5).

**Please note that even with an IP65 rating, this unit is intended only for temporary outdoor usage.**

### MARINE/COASTAL ENVIRONMENT INSTALLATIONS



NOT suitable for marine and/or coastal environment installations. Installing this fixture in a marine and/or coastal environment may cause corrosion and/or excessive wear to the interior and/or exterior components of the fixture. Damages and/or performance issues resulting from installation in a marine and/or coastal environment will void the manufactures warranty and will NOT be subject to any warranty claims and/or repairs.

# SAFETY GUIDELINES

**FOR YOUR OWN PERSONAL SAFETY, PLEASE READ AND UNDERSTAND THIS MANUAL COMPLETELY BEFORE YOU ATTEMPT TO INSTALL OR OPERATE THIS UNIT!**

- **THERE ARE NO USER SERVICEABLE PARTS INSIDE THIS UNIT. DO NOT ATTEMPT ANY REPAIRS YOURSELF; DOING SO WILL VOID YOUR MANUFACTURES WARRANTY. DAMAGES RESULTING FROM MODIFICATIONS TO THIS FIXTURE AND/OR THE DISREGARD OF SAFETY INSTRUCTIONS AND GUIDELINES IN THIS MANUAL VOID THE MANUFACTURES WARRANTY AND ARE NOT SUBJECT TO ANY WARRANTY CLAIMS AND/OR REPAIRS.**
- **DO NOT PLUG THE FIXTURE INTO A DIMMER PACK! NEVER OPEN THIS FIXTURE WHILE IN USE! UNPLUG POWER BEFORE SERVICING FIXTURE! NEVER TOUCH THE FIXTURE DURING OPERATION AS IT MAY BE HOT! KEEP FLAMMABLE MATERIALS AWAY FROM FIXTURE! ENSURE ALL CONNECTIONS AND END CAPS ARE PROPERLY SEALED WITH A DIELECTRIC GREASE (AVAILABLE AT MOST ELECTRICAL SUPPLIERS) TO PREVENT WATER CORROSION AND/OR ELECTRICAL SHORT CIRCUIT.**
- **IF THE FIXTURE IS EXPOSED TO ENVIRONMENTAL TEMPERATURE CHANGES SUCH AS RELOCATION FROM AN OUTDOOR COLD TO AN INDOOR WARM ENVIRONMENT, DO NOT POWER THE FIXTURE ON IMMEDIATELY. INTERNAL CONDENSATION AS A RESULT OF ENVIRONMENTAL TEMPERATURE CHANGE CAN CAUSE INTERNAL FIXTURE DAMAGE. LEAVE THE FIXTURE POWERED OFF UNTIL IT HAS REACHED ROOM TEMPERATURE BEFORE POWERING ON.**
- **NEVER LOOK DIRECTLY INTO THE LIGHT SOURCE! RETINA INJURY RISK - MAY INDUCE BLINDNESS SENSITIVE PERSONS MAY SUFFER AN EPILEPTIC SHOCK!**
- Replace shields, lenses or ultraviolet screens if they have become visibly damaged to such an extent that their effectiveness is impaired, for example by cracks or deep scratches.

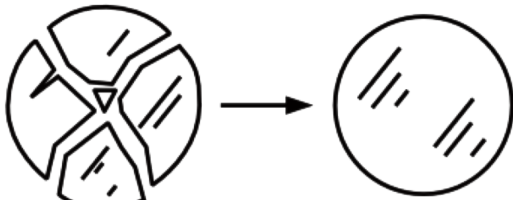

**Ø3.6" (98mm) Round**

- Change the lamp if it has become damaged or thermally deformed.
- The luminaire is intended for professional use only.
- The light source contained in this luminaire shall only be replaced by the manufacturer, qualified service agent, or a similar qualified technician.
- Reinforced insulation is located between LV supply and DMX dimming control circuit.
- No insulation located between SELV circuit and DMX dimming control circuit.
- Be sure that the local power outlet is compatible with the required voltage for your unit. • Do not attempt to operate this unit if the power cord has been frayed or broken.
- Do not attempt to remove or break off the ground prong from the electrical cord. internal short.
- Disconnect from main power before making any type of connection.
- Do not remove the cover under any conditions. There are no user serviceable parts inside. • Never operate this unit when it's cover is removed.
- Always be sure to mount this unit in an area that will allow proper ventilation. Allow about 7.9" (20cm) between this device and a wall.
- Do not attempt to operate this unit, if it becomes damaged. • Always mount this unit in safe and stable matter.
- Power-supply cords should be routed so that they are not likely to be walked on or pinched by items placed upon or against them, paying particular attention to cords at plugs, convenience receptacles, and the point where they exit from the appliance.
- Cleaning -The fixture should be cleaned only as recommended by the manufacturer.
- Heat -This fixture should be situated away from heat sources such as radiators, heat registers, stoves, or other appliances (including amplifiers) that produce heat.
- The fixture should be serviced by qualified service personnel when the appliance does not appear to operate normally or exhibits a marked change in performance.



# SAFETY GUIDELINES

To guarantee a smooth operation, it is important to follow all instructions and guidelines in this manual. ADJ Products, LLC is not responsible for injury and/or damages resulting from the misuse of this fixture due to the disregard of the information printed in this manual. Only qualified and/or certified personnel should perform installation of this fixture and only the original rigging parts included with this fixture should be used for installation. Any modifications to the fixture and/or the included mounting hardware will void the original manufactures warranty and increase the risk of damage and/or personal injury.



## **PROTECTION CLASS 1 - FIXTURE MUST BE PROPERLY GROUNDED**



**THERE ARE NO USER SERVICEABLE PARTS INSIDE THIS UNIT. DO NOT ATTEMPT ANY REPAIRS YOURSELF; DOING SO WILL VOID YOUR MANUFACTURES WARRANTY. DAMAGES RESULTING FROM MODIFICATIONS TO THIS FIXTURE AND/OR THE DISREGARD OF SAFETY INSTRUCTIONS AND GUIDELINES IN THIS MANUAL VOID THE MANUFACTURES WARRANTY AND ARE NOT SUBJECT TO ANY WARRANTY CLAIMS AND/OR REPAIRS.**



**DO NOT PLUG FIXTURE INTO A DIMMER PACK!  
NEVER OPEN THIS FIXTURE WHILE IN USE!  
UNPLUG POWER BEFORE SERVICING FIXTURE!  
NEVER TOUCH FIXTURE DURING OPERATION AS IT MAY BE HOT!**

**Maximum ambient temperature is  $T_a$ : 40°C. DO NOT operate it where the temperature is higher than this. Unit surface temperature may reach up to 75°C. DO NOT touch the housing bare-hand during its operation. Turn off the power and allow about 15 minutes for the unit to cool down before replacing or serving.**

**KEEP FLAMMABLE MATERIALS AWAY FROM FIXTURE!**



**ENSURE ALL CONNECTIONS AND END CAPS ARE PROPERLY SEALED WITH A DIELECTRIC GREASE (AVAILABLE AT MOST ELECTRICAL SUPPLIERS) TO PREVENT WATER CORROSION AND/OR ELECTRICAL SHORT CIRCUIT.**



**IF THE FIXTURE IS EXPOSED TO ENVIRONMENTAL TEMPERATURE CHANGES SUCH AS RELOCATION FROM AN OUTDOOR COLD TO AN INDOOR WARM ENVIRONMENT, DO NOT POWER THE FIXTURE ON IMMEDIATELY. INTERNAL CONDENSATION AS A RESULT OF ENVIRONMENTAL TEMPERATURE CHANGE CAN CAUSE INTERNAL FIXTURE DAMAGE. LEAVE THE FIXTURE POWERED OFF UNTIL IT HAS REACHED ROOM TEMPERATURE BEFORE POWERING ON.**



**NEVER LOOK DIRECTLY INTO THE LIGHT SOURCE! RETINA INJURY RISK - MAY INDUCE BLINDNESS! SENSITIVE PERSONS MAY SUFFER AN EPILEPTIC SHOCK!  
THIS IS A RISK GROUP 3 (HIGH RISK) PRODUCT ACCORDING TO EN 62471 AND IEC/ TR 62778. THE LUMINAIRE SHOULD BE POSITIONED 63METERS OR MORE FROM THE OUTPUT OF THE FIXTURE TO REDUCE OR ELIMINATE EXPOSURE.**



# SAFETY GUIDELINES

**⚠ CAUTION**

**HIGH  
INTENSITY  
ULTRAVIOLET  
LIGHT**



AVOID DIRECT EYE & SKIN EXPOSURE.  
WEAR PROPER EYE & SKIN PROTECTION.  
SEE MANUAL FOR SAFETY INSTRUCTIONS

**RISK GROUP 3 - RISK OF EXPOSURE TO ULTRAVIOLET UV RADIATION! FIXTURE EMITS HIGH INTENSITY WAVELENGTH OF ULTRAVIOLET UV LIGHT FROM THE UV COLOR FILTER. WEAR PROPER EYE AND SKIN PROTECTION. AVOID PROLONGED PERIODS OF EXPOSURE TO UV COLOR FILTER. AVOID WEARING WHITE COLOR CLOTHING AND/OR USING UV PAINTS ON SKIN. AVOID DIRECT EYE AND/OR SKIN**

**EXPOSURE AT DISTANCES LESS THAN 11 feet (3.3m). DO NOT OPERATE FIXTURE WITH DAMAGED/MISSING EXTERNAL COVERS. DO NOT LOOK DIRECTLY INTO THE UV LIGHT AND/OR VIEW UV LIGHT DIRECTLY WITH OPTICAL INSTRUMENTS THAT MAY CONCENTRATE THE LIGHT/RADIATION OUTPUT. INDIVIDUALS SUFFERING FROM A RANGE OF EYE CONDITIONS, SUNLIGHT EXPOSURE DIS-ORDERS, OR INDIVIDUALS USING PHOTSENSITIVE MEDICATION, MAY RECEIVE DISCOMFORT IF EXPOSED TO THE ULTRAVIOLET UV LIGHT EMITTED FROM THE UV LED.**

**DO NOT TOUCH** the fixture housing during operation. Turn OFF the power and allow approximately 15 minutes for the fixture to cool down before servicing.

**DO NOT** shake fixture; avoid brute force when installing and/or operating fixture.

**DO NOT** operate fixture if the power cord has become frayed, crimped, damaged and/or if any of the power cord connectors are damaged and do not insert into the fixture securely with ease.

**NEVER** force a power cord connector into the fixture. If the power cord or any of its connectors are damaged, replace it immediately with a new one of similar power rating.

**DO NOT** block any air ventilation slots; these must remain clean and never blocked. Allow approx. 7.9" (20cm) between fixture and other devices or a wall for proper cooling.

When installing fixture in a suspended environment, always use mounting hardware that is no less than M10 x 25 mm, and always attach an appropriately rated safety cable.

**ALWAYS** disconnect fixture from main power source before performing any type of service and/or cleaning procedure. Only handle the power cord by the plug end; never pull out the plug by tugging the wire portion of the cord.

During the initial operation of this fixture, a light smoke or smell may emit from the interior of the fixture. This is a normal process and is caused by excess paint in the interior of the casing burning off from the heat associated with the lamp and will decrease gradually over time.

Consistent operational breaks will ensure fixture will function properly for many years. **ONLY** use the original packaging and materials to transport the fixture in for service.

# SAFETY GUIDELINES

## POTENTIAL INTERNAL FIXTURE DAMAGE FROM EXTERNAL SOURCES OF LIGHT BEAMS

External sources of light beams from direct sunlight, lighting moving head fixtures, and lasers, which are focused directly towards the exterior housing and/or penetrate the front lens opening of ADJ lighting fixtures, can cause severe internal damage including burning to optics, dichroic color filters, glass and metal gobos, prisms, animation wheels, frost filters, iris, shutters, motors, belts, wiring, discharge lamps, and LEDs.

This issue is not specific only to ADJ lighting fixtures, it is a common issue with lighting fixtures from all manufacturers. Although there is no true way to fully prevent this issue from happening, the guidelines below can prevent any potential damage from occurring if followed. Contact ADJ Service for more details.

**DO NOT EXPOSE THE FIXTURE AND/OR FRONT LENS OPENING TO LIGHT BEAMS FROM DIRECT SUNLIGHT, OTHER LIGHTING MOVING HEAD FIXTURES, AND LASERS WHILE UNPACKING, INSTALLATION, USE, AND EXTENDED IDLE TIMES OUTDOORS.**  
**DO NOT FOCUS A LIGHT BEAM FROM ONE LIGHTING FIXTURE DIRECTLY TOWARDS ANOTHER.**

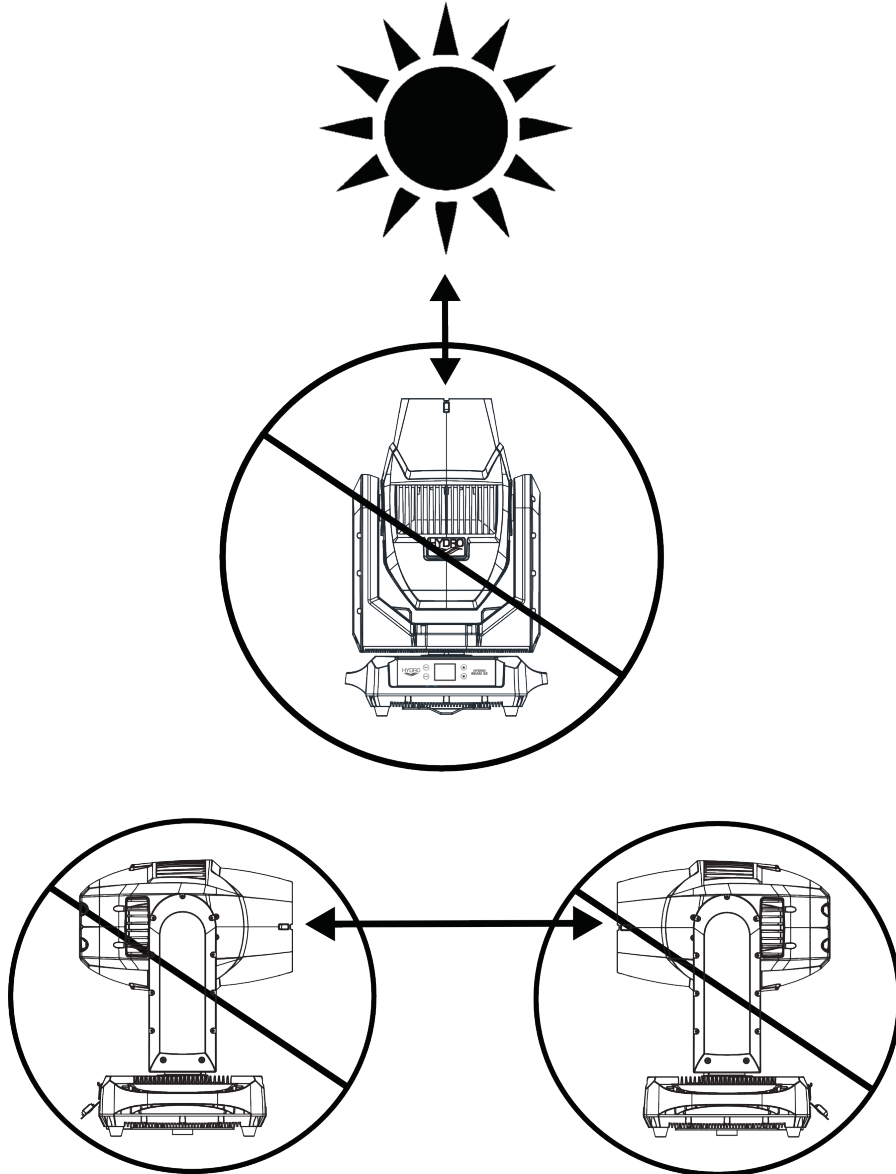

# OVERVIEW

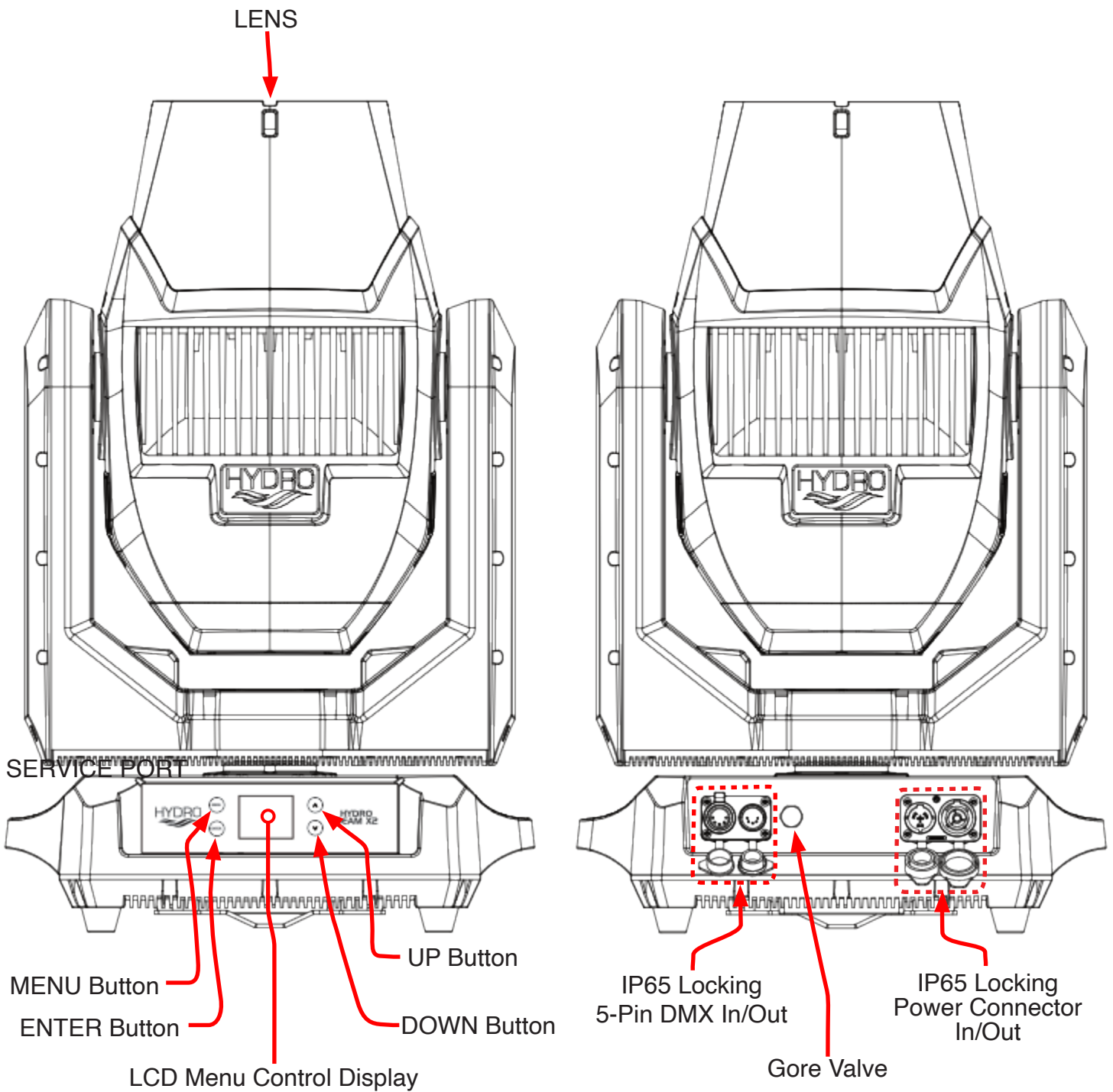

## DISCHARGE LAMP WARNING

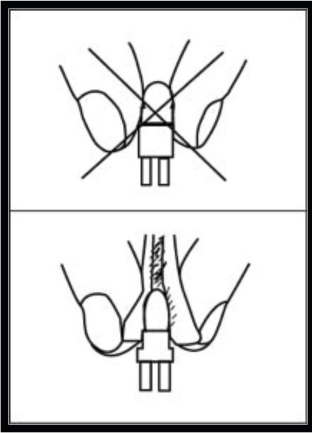

This fixture is fitted with a DISCHARGE LAMP, which is highly susceptible to damage if improperly handled. NEVER touch the lamp with your bare hands as the oil from your hands will shorten the life of the lamp. Also, NEVER move the fixture until the lamp has had ample time to cool. Lamps are NOT covered under warranty conditions. Avoid switching the fixture ON and OFF repeatedly in short intervals as this will reduce lamp life and intensity. To achieve the intensity associated with discharge lamps, these lamps use gas sealed in a high-pressure environment to emit a brilliant output.

Due to the high pressure involved with the construction of the lamp, the lamp MAY EXPLODE DURING PROLONGED EXTENSIVE USE. This risk is increased with age; added care is encouraged when dealing with older lamps. Thus, the lamp must always be replaced at the end of their recommended duty cycle. Extreme caution should be used when



**UV RADIATION NOTICE**

This fixture emits intense UV radiation, which is harmful to the eyes and skin. The intense luminescence of the lamp can cause severe damage to the retina. NEVER operate this fixture with ANY of the protective covers removed. These covers have been specially designed to shield against UV radiation.

operating this or any fixture fitted with a gas discharge lamp.

## LAMP REPLACEMENT WARNING

**NOTE: The lamp life is represented in “Percentages”.**

When the unit reaches 15% of lamp life left, the display will flash the message, “**Replace The Lamp Soon**”. This message will flash for up to 10 minutes. To confirm this warning and return to normal operation, press the **ENTER** button.

When the unit reaches 10% of lamp life left, the display will again flash the message, “**Replace The Lamp Soon**”. This message will flash for up to 10 minutes. To confirm this warning and return to normal operation, press the **ENTER** button.

**NOTE: When the fixture is powered OFF and then back ON again, the fixture display will flash the following message: “Replace The Lamp Soon”.**

When the unit reaches between 5%-0% of lamp life left, the display will flash the message “**Replace The Lamp Immediately**”. The unit will now NO longer respond to DMX commands and enter hibernation mode which will discontinue all fixture functionality with the exception of a few menu commands. The fixture will continue to enter into hibernation mode until the lamp is replaced and the lamp time (**LAMP ON TIME-R**) has been reset. See page 36 “**LAMP ON TIME-R**” under the “**TOTAL LAMP TIME**” submenu.

**NOTE: After replacing the lamp, the lamp time MUST be reset. The lamp time must be reset to gain access to the full system menu.**



Lamp Life may vary depending on several factors including but not limited to: Environmental Conditions, Power/Voltage, Usage Patterns (On-Off Cycling), Control, and Dimming.

## LAMP INSTALLATION



**WARNING! LAMP REPLACEMENT SHOULD ONLY BE DONE BY A TRAINED TECHNICIAN.**

1. Turn OFF power and allow approximately 15 minutes for the fixture to cool down.

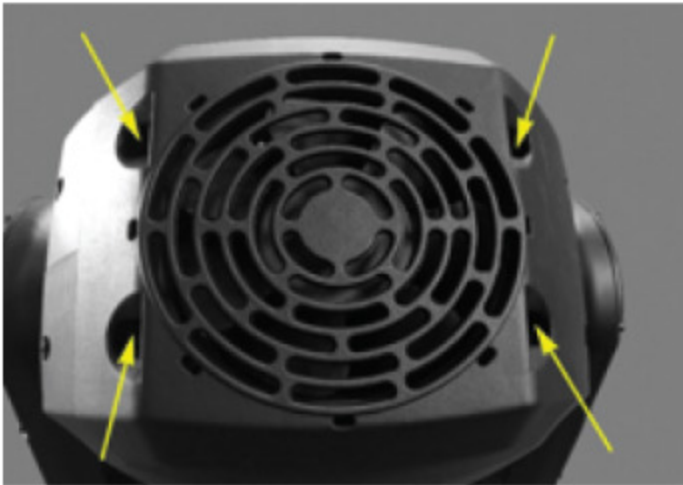

2. Unscrew the (4x) Allen Head Screws to remove the rear cover. When removing the rear cover, please be advised that the cover is connected to the unit via a safety cable and connected wire cable.

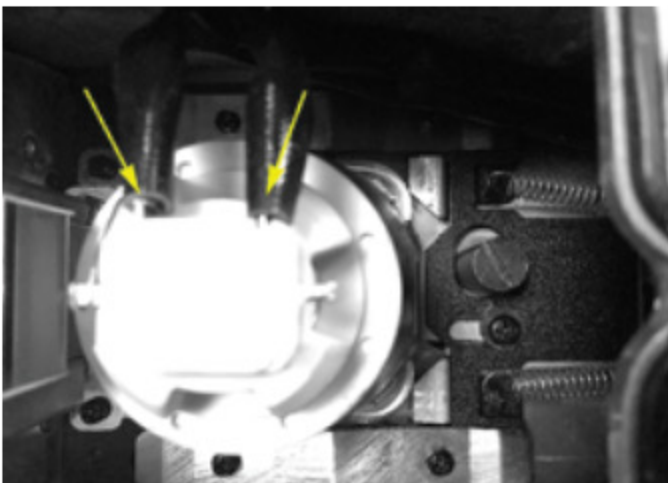

3. Gently remove the (2x) spade terminals connected to the lamp.

4. Loosen the Phillips head screw to unlock the lamp holding slider.



## LAMP INSTALLATION

5. Carefully slide the lamp to the right and tighten the Phillips head screw. Carefully remove the lamp from its holder and replace with the same type lamp.



6. Once the new lamp has been inserted, loosen the Phillips head screw again to allow the lamp holding mechanism to slide back to its closed position. Tighten the Phillips head screw.

Reconnect the (2x) spade terminal and replace the cover and tighten the (4x) Allen screws.



# TORQUE SETTINGS FOR SCREWS

All screws are Allen Head screws. Please see below for screw locations, screw quantity and torque settings. The number listed in the “#” column corresponds to the location on the fixture.

1	Lens Assembly to Head Casting (x14)	6.5-8.7 In-Lb / 3mm Hex
2	Lamp Cover to Head Casting (x4)	6.7-9.6 In-Lb / 4mm Hex
3	Plastic Head Cover to Head Casting (4 x Each Side = 8 Total)	6.5-8.7 In-Lb / 3mm Hex
4	Yoke Arm Cover to Yoke Frame (11 x Each Side = 22 Total)	6.5-8.7 In-Lb / 3mm Hex
5	Access Cover to Yoke Frame (x4)	Manual Screwdriver / 3mm Hex
6	Bottom Cover to Base Casting (x16)	6.7-9.6 In-Lb / 3mm Hex
7	Power & Data Connector to Base Casting (x8)	6.5-8.7 In-Lb / Torx T8
8	1/4 Turn Adapter Plate to Bottom Cover (x16)	6.5-8.7 In-Lb / 3mm Hex

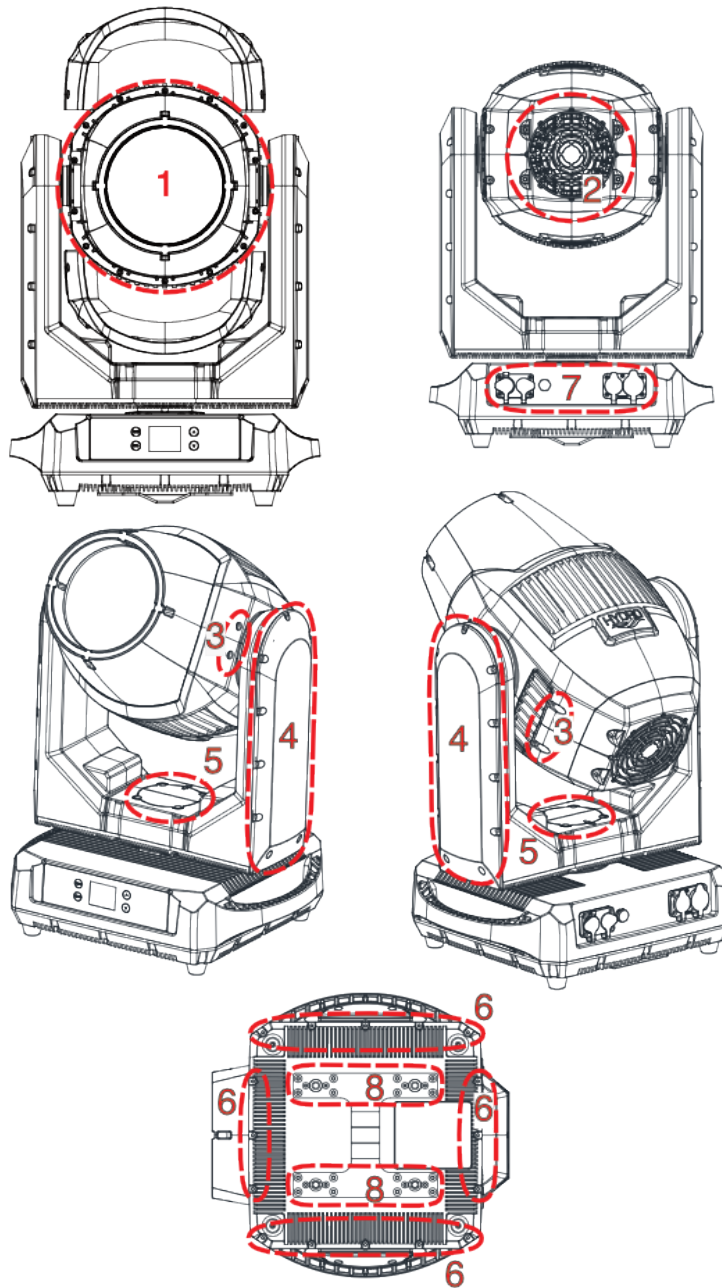



# TORQUE SETTINGS FOR SCREWS

A TORQUE DRIVER SHOULD BE USED TO SECURE ALL SCREWS ON THE FIXTURE!

TORQUE DRIVERS (Recommended): UTICA TS-30 (Shown)

ALTERNATIVE DRIVERS:

Proto J6107A

Wiha 28887



**CAUTION! DO NOT OVER TORQUE SCREWS AS THIS CAN CAUSE LEAKAGE ISSUES! TO CONFIRM THE IP65 INTEGRITY AFTER A LAMP REPLACEMENT, TEST THE FIXTURE USING THE ELATION IP TESTER. CONTACT ELATION SERVICE FOR MORE DETAILS.**



**CAUTION! THE USE OF PROTECTIVE GLOVES AND SAFETY GOGGLES IS STRONGLY RECOMMENDED WHILE PERFORMING THE IP PRESSURE TEST! AVOID PLACING YOUR FACE, EYES, HANDS, ETC IN CLOSE PROXIMITY TO THE FIXTURE'S LENS WHILE PERFORMING THE TEST!**



IP PRESSURE TESTING PARAMETERS			
Test Type	Target Value	Acceptable Change Due to Leakage	Hold Time
Vacuum Test	-4.4 psi (-30 KPa)	0.7 psi (4.5 KPa)	60 sec
Pressure Test	1.9 psi (13 KPa)	0.7 psi (4.5 KPa)	60 sec

# GOBO SPECIFICATIONS

\*\*\* IMPORTANT NOTICE REGARDING CUSTOM GOBOS \*\*\*

Due to the extreme high temperature optical system, special BOROFLOAT glass material and design criteria are required.

Due to varying gobo manufacturing processes and tolerances, it is highly recommended to provide a gobo sample and gobo holder/wheel sample from the fixture to the custom gobo vendor for accurate sizing. Gobo specifications below including diameter, thickness, and materials have been tested and are compatible in this fixture.

Using custom gobos that do not match the gobo specifications below, is not recommended and any damage to the fixture as a result of using a custom gobo is NOT covered under warranty. Extended testing of custom gobo designs is highly recommended prior to using.

**PLEASE CONTACT ADJ CUSTOMER SUPPORT FOR FURTHER INFORMATION.**

<b>ROTATING GLASS</b>	
<b>GOBOS Gobo O.D. (Max. Outer Diameter)</b>	<b>Ø9.8mm</b>
<b>Gobo I.D. (Max. Image Diameter)</b>	<b>Ø6.5mm</b>
<b>Gobo Holder Diameter</b>	<b>Ø10mm</b>
<b>Gobo Thickness</b>	<b>Ø1.1mm</b>
<b>Gobo Material</b>	<b>BOROFLOAT</b>

## GOBOS



GOBO 1



GOBO 2



GOBO 3



GOBO 4



GOBO 5



GOBO 6



GOBO 7



GOBO 8



GOBO 9



GOBO 10



GOBO 11

# GOBO INSTALLATION



**WARNING! GOBO REPLACEMENT SHOULD ONLY BE DONE BY A TRAINED TECHNICIAN.  
TURN OFF POWER AND ALLOW APPROXIMATELY 60 MINUTES FOR THE  
FIXTURE TO COOL DOWN.**

Unscrew and remove the 8 screws that secure the moving head shells.

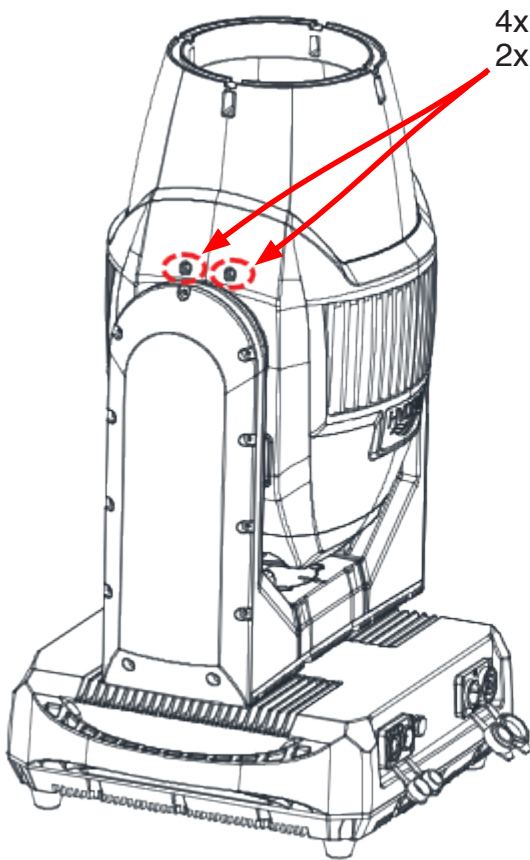

4x Screws Total  
2x Screws per side

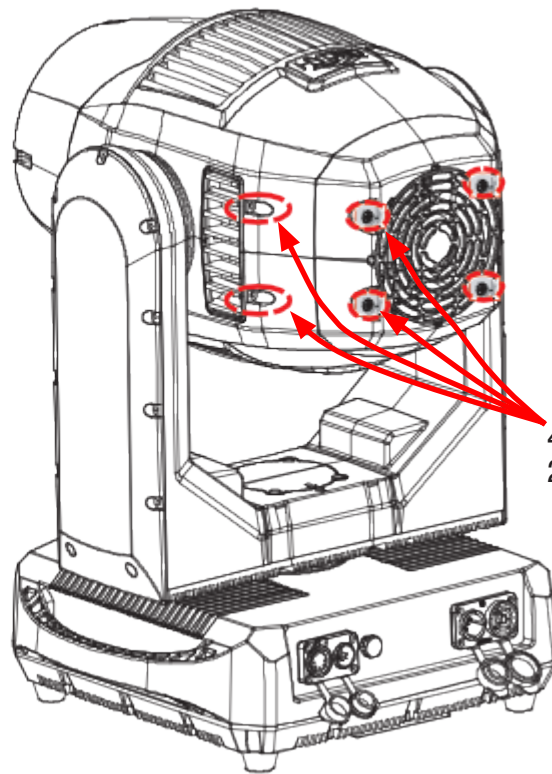

4 x Screws Total  
2 x Screws per side

# GOBO INSTALLATION

Remove both moving head shells

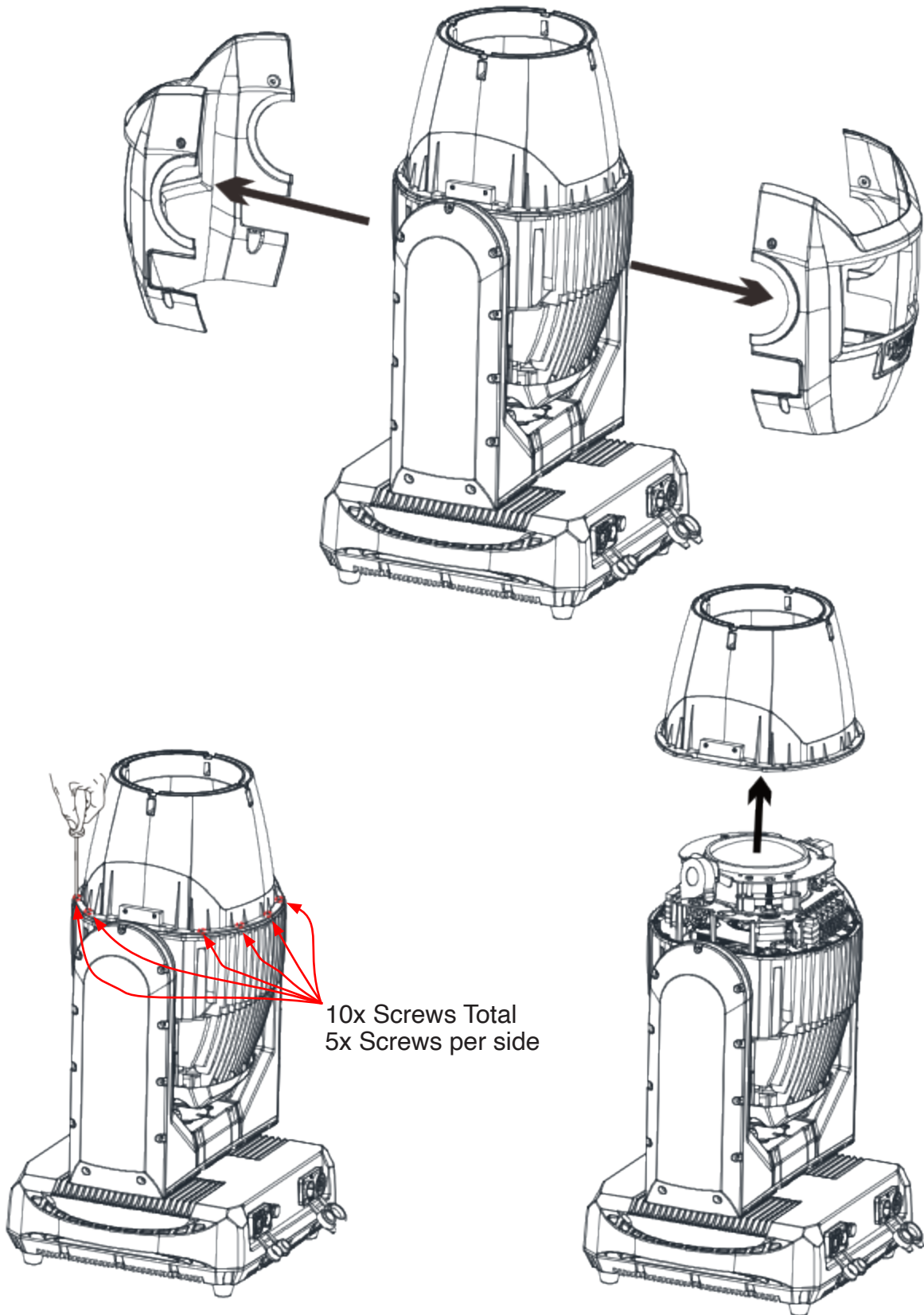

After the moving head shells have been removed unscrew and remove the 10 screws that secure the head in place. Carefully remove the head to access the inside module.



## GOBO INSTALLATION

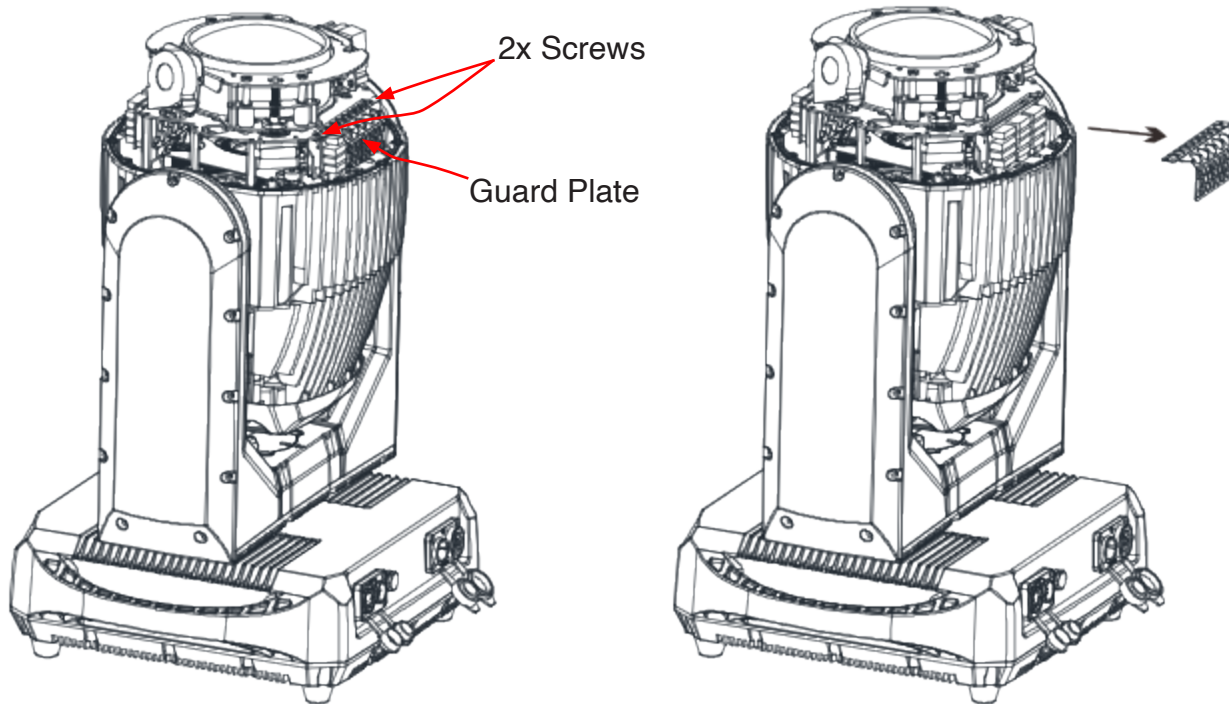

**Note: Disconnect the cables with RED sleeves before dismantling head module.**

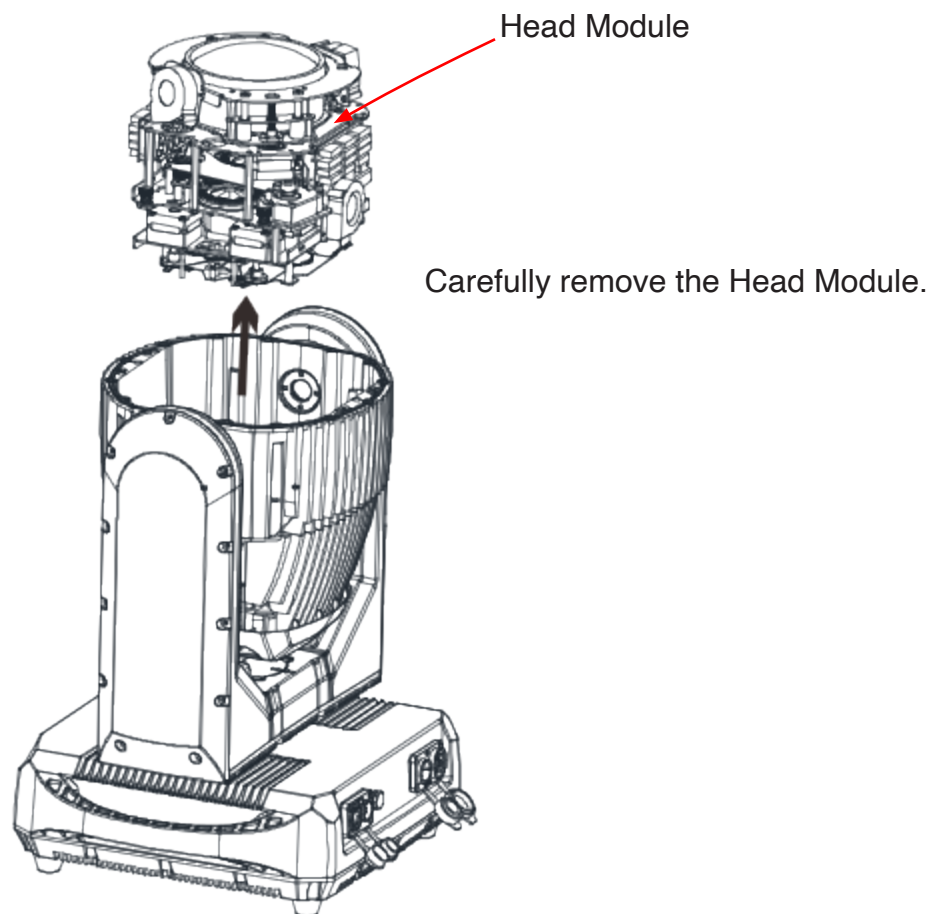

# GOBO INSTALLATION

Unscrew and remove the 4 screws that secure the Insulation Board

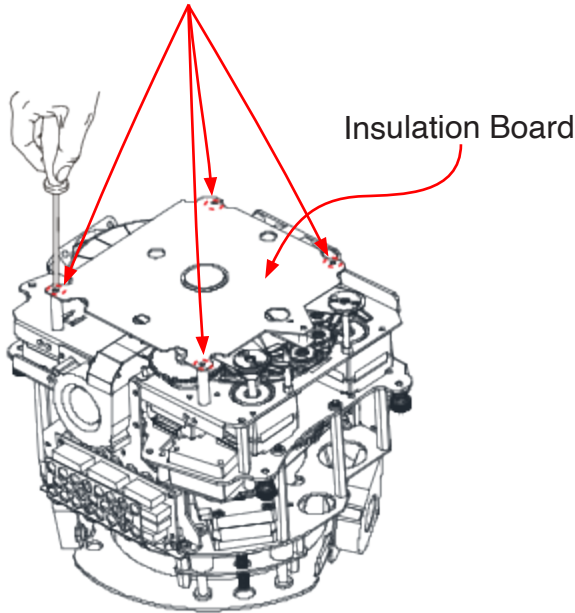

Carefully remove the Insulation Board

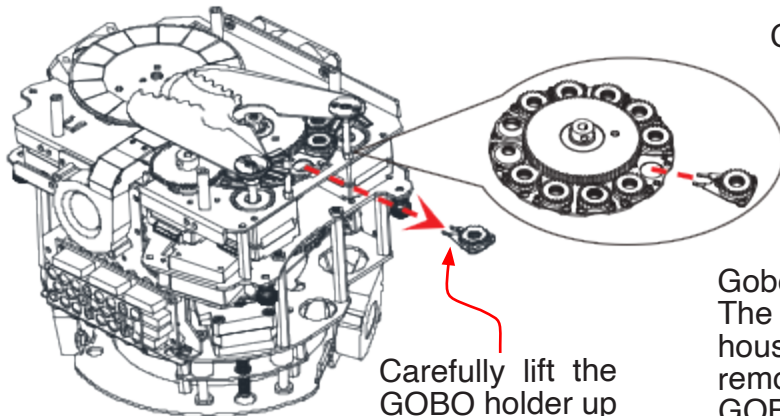
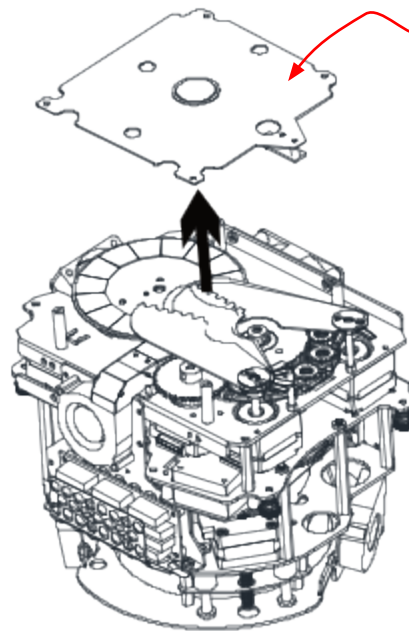

Carefully lift the GOBO holder up and out from the GOBO wheel.

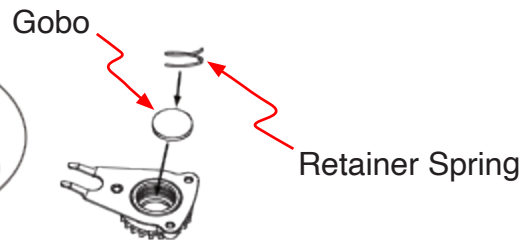

**Gobo Replacement:**  
The GOBO is secured into the gobo housing by a retainer spring. Carefully remove the retainer spring that holds the GOBO in place. Carefully remove the GOBO from the GOBO holder. Replace with your desired GOBO, and reinsert the retainer spring into place.

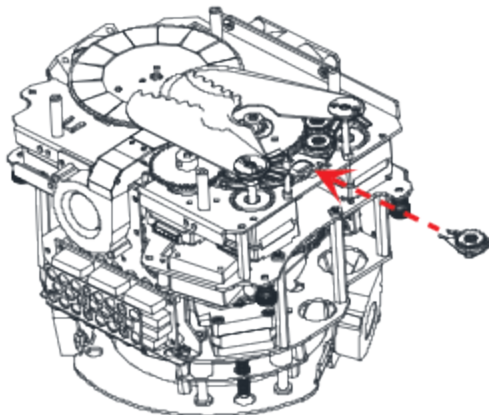

## FIXTURE INSTALLATION



### **FLAMMABLE MATERIAL WARNING**

Keep fixture at least 7.9in. (0.2m) away from any flammable materials, decorations, pyrotechnics, etc.



### **ELECTRICAL CONNECTIONS**

A qualified electrician should be used for all electrical connections and/or installations.



**MINIMUM DISTANCE TO OBJECTS/SURFACES MUST BE 40 FEET (12 METERS)**



**MAXIMUM TEMPERATURE OF EXTERNAL SURFACE 167°F (75°C)**

### **DO NOT INSTALL THE FIXTURE IF YOU ARE NOT QUALIFIED TO DO SO!**

Fixture **MUST** be installed following all local, national, and country commercial electrical and construction codes and regulations. Before rigging/mounting the fixture to any metal truss/structure or placing the fixture on any surface, a professional equipment installer **MUST** be consulted to determine if the metal truss/structure or surface is properly certified to safely hold the combined weight of the fixture, clamps, cables, and accessories.

Overhead fixture installation must always be secured with a secondary safety attachment, such as an appropriately rated safety cable that meets all local, national, and country codes and regulations.

Fixture ambient operating temperature range is **-4°F to 104°F. (-20°C to 40°C)** Do not use this fixture outside this temperature range.

Fixture should be installed in areas outside walking paths, seating areas, or away from areas where unauthorized personnel might reach the fixture by hand.

**NEVER** stand directly below the fixture when rigging, removing, or servicing.

Allow approximately 15-minutes for the fixture to cool down before servicing.



## FIXTURE INSTALLATION

**NOTICE:** The suitable environmental temperature for this lighting fixture is between  $-20^{\circ}\text{C}$  to  $40^{\circ}\text{C}$ . Do not place this lighting fixture in an environment where the temperatures are under or above the temperatures stated above. This will allow the fixture to run at its best and help prolong the fixture life.

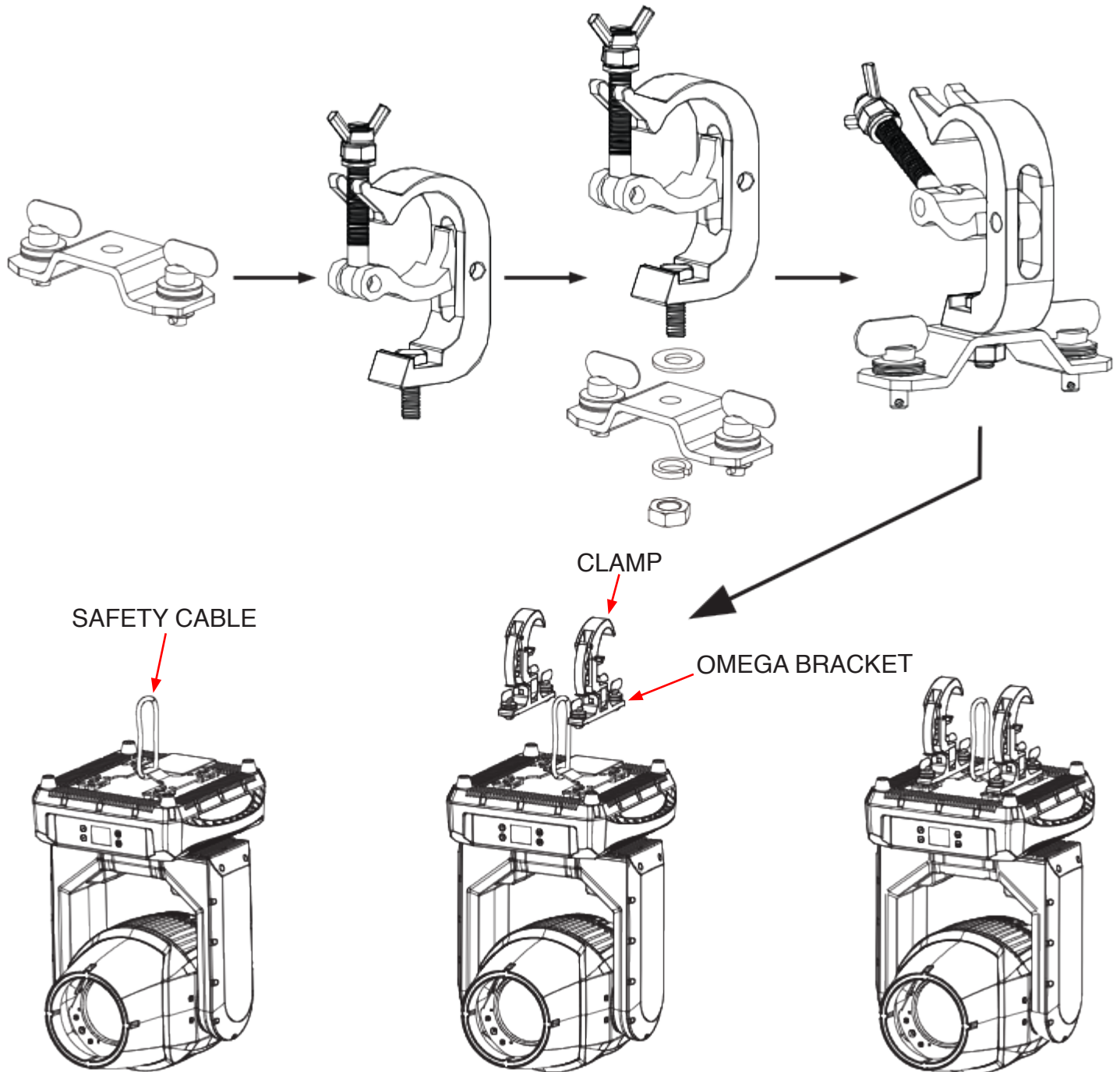

Screw one clamp via a M12 screw and nut into the Omega holder. Insert the quick-lock fasteners of the Omega holder into the respective holes of the adjustable mounting bracket. Tighten the quick-lock fasteners fully clockwise. Pull the safety-cable through the opening located on the bottom of the unit and over the trussing system or a safe fixation spot. Insert the end in the carabiner and tighten the safety screw.

# FIXTURE INSTALLATION

When installing the unit, the trussing or area of installation must be able to hold 10 times the weight without any deformation. When installing the unit must be secured with a secondary safety attachment, e.g. and appropriate safety cable. Never stand directly below the unit when mounting, removing, or servicing the unit.

Overhead mounting requires extensive experience, including calculating working load limits, installation material being used, and periodic safety inspection of all installation material and unit. If you lack these qualifications, do not attempt the installation yourself.

These installations should be checked by a skilled person once a year.

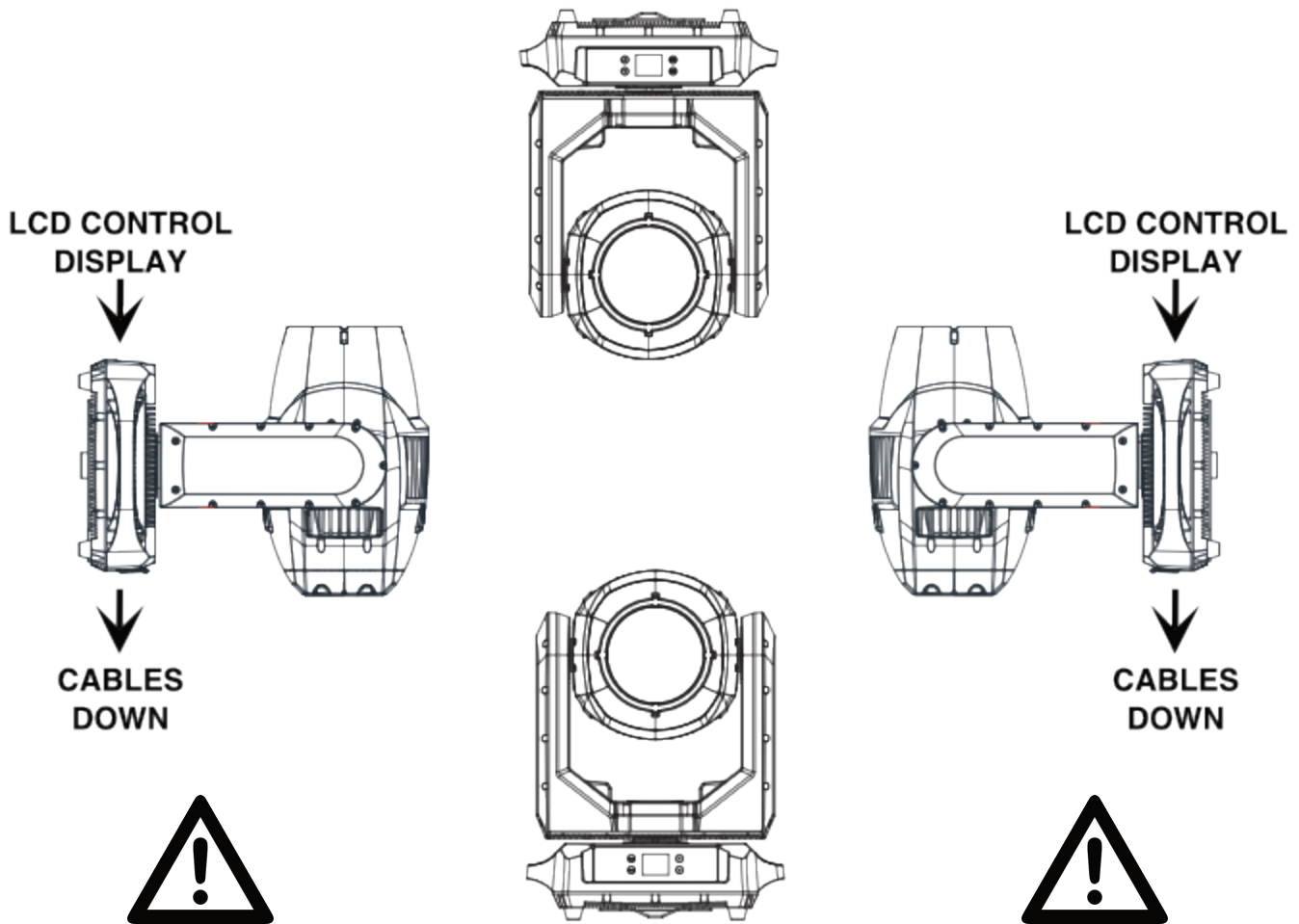

## \*SIDE MOUNTING

TO MAINTAIN IP65 RATING INTEGRITY, FIXTURE MUST BE INSTALLED WITH CABLES FACING THE GROUND AT ALL TIMES. WATER MUST EASILY RUN OFF AND NOT COLLECT AROUND CABLE CONNECTIONS.

## \*SAFETY CABLE

ALWAYS ATTACH A SAFETY CABLE WHENEVER INSTALLING THIS FIXTURE IN A SUSPENDED ENVIRONMENT TO ENSURE THE FIXTURE WILL NOT DROP IF THE CLAMP FAILS.

The Hydro Beam X2 is fully operational in three different mounting positions, hanging upside-down, mounted sideways on trussing, or set on a flat level surface. Be sure this fixture is kept at least 0.2m (7.9in.) away from any flammable materials (decoration etc.). Always use and install the supplied safety cable as a safety measure to prevent accidental damage and/or injury in the event the clamp fails (see next page). Never use the carrying handles for secondary attachment.

## CONNECTIONS

ENSURE ALL CONNECTIONS AND END CAPS ARE PROPERLY SEALED WITH A DIELECTRIC GREASE (AVAILABLE AT MOST ELECTRICAL SUPPLIERS) TO PREVENT WATER CORROSION AND/OR ELECTRICAL SHORT CIRCUIT.

TO MAINTAIN IP65 RATING INTEGRITY AND PREVENT WATER FROM ENTERING THE FIXTURE, ALL UNUSED CONNECTION RUBBER CAPS MUST BE SEALED.

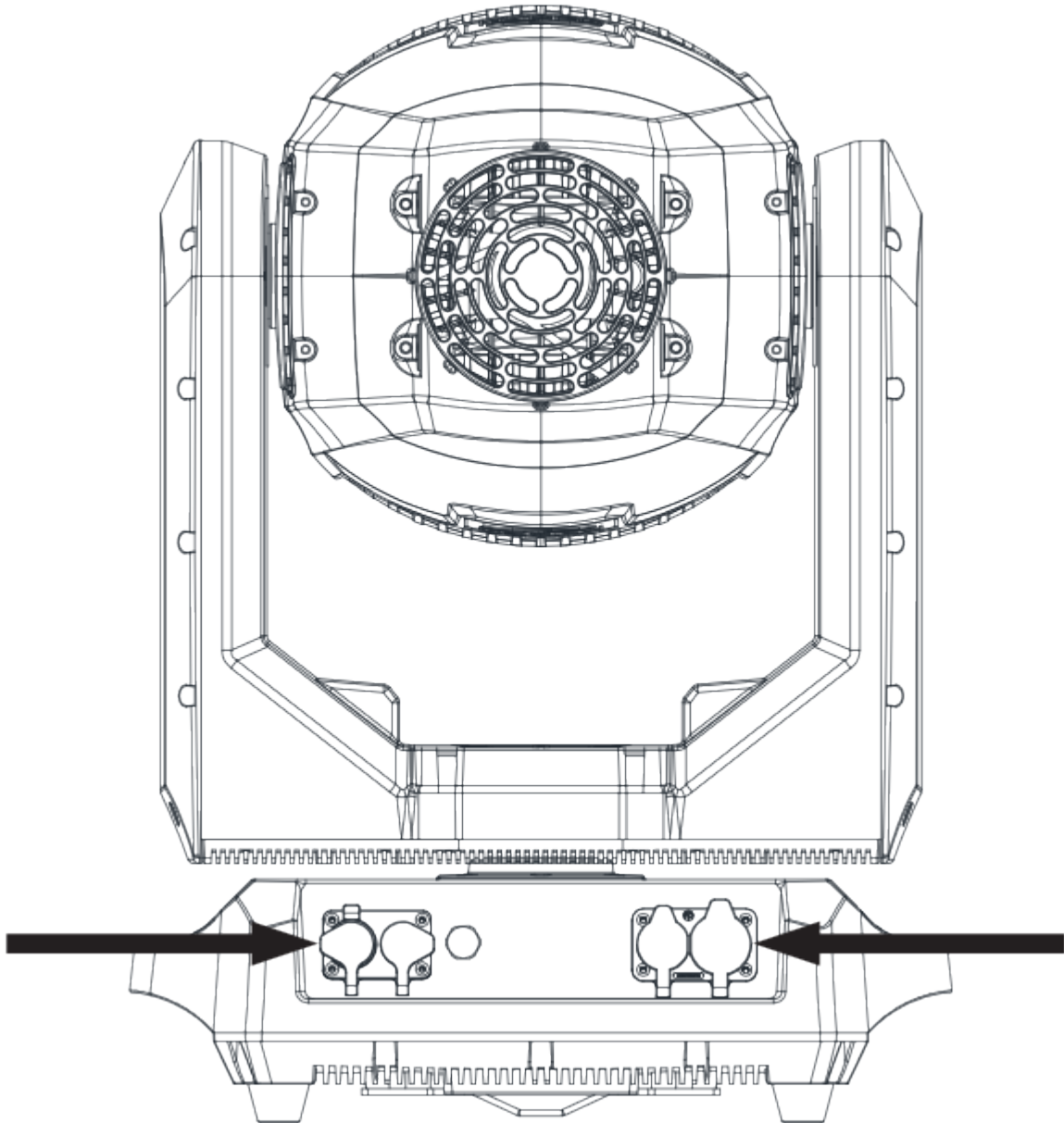

## REMOTE DEVICE MANAGEMENT (RDM)

**NOTE:** In order for RDM to work properly, RDM enabled equipment must be used throughout the entire system, including DMX data splitters and wireless systems.

Remote Device Management (RDM) is a protocol that sits on top of the DMX512 data standard for lighting, allowing the DMX systems of the fixtures to be modified and monitored remotely. This protocol is ideal for instances in which a unit is installed in a location that is not easily accessible.

With RDM, the DMX512 system becomes bi-directional, allowing a compatible RDM enabled controller to send out a signal to devices on the wire, as well as allowing the fixture to respond (known as a GET command). The controller can then use its SET command to modify settings that would typically have to be changed or viewed directly via the unit's display screen, including the DMX Address, DMX Channel Mode, and Temperature Sensors.

### FIXTURE RDM INFORMATION:

RDM Code	Device ID	Device Model ID	Personality ID
0x1900	Random	0x047C	0x0102 (15Ch) 0x0202 (17Ch)

**Please be aware that not all RDM devices support all RDM features**, and therefore it is important to check beforehand to ensure that the equipment that you are considering includes all of the features that you require.

The following parameters are accessible in RDM on this device:

Disc Unique Branch	DMX Personality
Disc Mute	DMX Personality Description
Disc Unmute	Sensor Definition
Device Info	Sensor Value
Supported Parameters	Device Hours
Software Version Label	Lamp Hours
DMX Start Address	Lamp State
Identify Device	Lamp On Mode
Device Model Description	Pan Invert
Status Messages	Tilt Invert
Manufacturer Label	Reset Device
Device Label	

## DMX SETUP

**DMX-512:** DMX is short for Digital Multiplex. This is a universal protocol used as a form of communication between intelligent fixtures and controllers. A DMX controller sends DMX data instructions from the controller to the fixture. DMX data is sent as serial data that travels from fixture to fixture via the DATA “IN” and DATA “OUT” XLR terminals located on all DMX fixtures (most controllers only have a DATA “OUT” terminal).

**DMX Linking:** DMX is a language allowing all makes and models of different manufactures to be linked together and operate from a single controller, as long as all fixtures and the controller are DMX compliant. To ensure proper DMX data transmission, when using several DMX fixtures try to use the shortest cable path possible. The order in which fixtures are connected in a DMX line does not influence the DMX addressing. For example; a fixture assigned a DMX address of 1 may be placed anywhere in a DMX line, at the beginning, at the end, or anywhere in the middle. When a fixture is assigned a DMX address of 1, the DMX controller knows to send DATA assigned to address 1 to that unit, no matter where it is located in the DMX chain.

**Data Cable (DMX Cable) Requirements (For DMX Operation):** The Hydro BeamX2 can be controlled via DMX-512 protocol. Your unit and your DMX controller requires a 5-pin XLR connector for data input and data output. We recommend Accu-Cable DMX cables. If you are making your own cables, be sure to use standard 110-120 Ohm shielded cable (This cable may be purchased at almost all pro lighting stores). Your cables should be made with a male and female XLR connector on either end of the cable. Also remember that DMX cable must be daisy chained and cannot be split.

**Special Note: Line Termination.** When longer runs of cable are used, you may need to use a terminator on the last unit to avoid erratic behavior. A terminator is a 110-120 ohm 1/4 watt resistor which is connected between pins 2 and 3 of a male XLR connector (DATA + and DATA -). This unit is inserted in the female XLR connector of the last unit in your daisy chain to terminate the line. Using a cable terminator (ADJ part number Z-DMX/T) will decrease the possibilities of erratic behavior.

**TO MAINTAIN IP65 RATING INTEGRITY AND PREVENT WATER FROM ENTERING THE FIXTURE, ALL UNUSED CONNECTION RUBBER CAPS MUST BE SEALED AND ONLY IP65 RATED POWER AND DATE CABLES MUST BE USED.**

## DMX ADDRESSING

All fixtures should be given a DMX starting address when using a DMX controller, so the correct fixture responds to the correct control signal. This digital starting address is the channel number from which the fixture starts to “listen” to the digital control signal sent out from the DMX controller. The assignment of this starting DMX address is achieved by setting the correct DMX address on the digital control display on the fixture.

You can set the same starting address for all fixtures or a group of fixtures, or set different addresses for each individual fixture. Setting all fixtures to the same DMX address will cause all fixtures to react in the same way, in other words, changing the settings of one channel will affect all the fixtures simultaneously.

If you set each fixture to a different DMX address, each unit will start to “listen” to the channel number you have set, based on the quantity of DMX channels of each fixture. That means changing the settings of one channel will only affect the selected fixture. In the case of the Hydro Beam X2, when in 15 Channel you should set the starting DMX address of the first unit to 1, the second unit to 16 (15 + 1), the third unit to 31 (16 + 15), and so on. (See the chart below for more details).

Channel Mode	Unit 1 Address	Unit 2 Address	Unit 3 Address	Unit 4 Address
15 Channels	1	16	31	46
17 Channels	1	18	35	52

## SYSTEM MENU

The fixture includes an easy to navigate system menu control panel display where all necessary settings and adjustments are made. (See image below) During normal operation, pressing the **MENU** button once will access the fixture's main menu. Once in the main menu, you can navigate through the different functions and access the sub-menus with the **UP** and **DOWN** buttons. When you reach a field that requires adjusting, press the **ENTER** button to access that field and use the **UP** and **DOWN** buttons to adjust the field. Pressing the **ENTER** button once more will confirm your setting. You may exit the main menu at any time without making any adjustments by pressing the **MENU** button.

**SYSTEM LOCK/UNLOCK:** When the display lock function is activated, the display and system menu will lock after 10 seconds of no activity. To **UNLOCK** the display, press and **HOLD** the **MENU** button for 10+ seconds.

While pressing the **MENU** button, a timer will appear at the bottom of the display indicating the passing seconds from 0-9. Once the timer reaches 9 seconds, the display will unlock allowing access to the system menu.

### **DO NOT RELEASE THE MENU BUTTON UNTIL THE DISPLAY IS UNLOCKED.**

If the **MENU** button is released before the timer reaches 9 seconds and/or is unlocked, the display will not unlock and the time will be reset.

**NOTE: The timer will not appear in the display if the lock function is disabled.**





# SYSTEM MENU (Software Version >V1.0.3)

Menu	Submenu	Options	Description	
DMX Settings	DMX Address	001-512	DMX Addressing	
	DMX CH Mode	15Ch / <b>17Ch</b>	DMX Channel Mode Selection	
	No DMX Status	<b>Hold Last</b> / Blackout / Manual	DMX Lost Status	
Personality	Select Signal	DMX: <b>Yes</b> / No	Control via DMX	
		WiFly: <b>Yes</b> / <b>No</b>	Control via WiFly	
		WiFly and DMX Out: <b>Yes</b> / <b>No</b>	Control via WiFly and send DMX Out via DMX cable	
	Status Settings	Pan Invert: On / <b>Off</b>	Reverse Pan Motion	
		Tilt Invert: On / <b>Off</b>	Reverse Tilt Motion	
		P/T. Feedback: On / <b>Off</b>	Pan/Tilt Movement Feedback	
		Pan Degree: <b>540</b>	Pan Degree	
		P./T. Speed: <b>Speed 1</b> / Speed 2	Pan/Tilt Movement Speed	
		Hibernation: Off / 01M~99M / <b>15M</b>	Sleep Setting (No Activity)	
	WiFly Settings	Set WiFly Channel: <b>00</b> ~14	Set WiFly Wireless Channel	
		Enable / <b>Disable</b> WiFly	Activate / Deactivate WiFly	
	Reset Motors	Reset All Motors: <b>Yes</b> / <b>No</b>	Reset All Motors	
		Pan/Tilt Reset: <b>Yes</b> / <b>No</b>	Reset the Pan & Tilt Motors	
		Color Reset: <b>Yes</b> / <b>No</b>	Reset the Color Wheel Motor	
		Gobo/R-G Reset: <b>Yes</b> / <b>No</b>	Reset the Gobo Wheel Motors	
		Prism1/R-P1 Reset: <b>Yes</b> / <b>No</b>	Reset the Prism 1 Motors	
		Prism2/R-P2 Reset: <b>Yes</b> / <b>No</b>	Reset the Prism 2 Motors	
		Shutter Reset: <b>Yes</b> / <b>No</b>	Reset the Shutter Motor	
		Focus Reset: <b>Yes</b> / <b>No</b>	Reset the Focus Motor	
		Frost Reset: <b>Yes</b> / <b>No</b>	Reset the Frost Motor	
	Display	Intensity: 1~ <b>10</b> (Dimmest-Brightest)	Display Brightness	
		Display Invert: <b>Yes</b> / <b>No</b>	Display Readout Inversion	
		Screen Saver Delay: <b>Off</b> ~10M	Display Shutoff Time	
		Lock On/Off: <b>On</b> / Off	Display Lock	
	Service	<b>Pass Code = 050</b>	Calibration ( <b>Pass Code = 050</b> )	Calibration Adjustment
			Factory Restore <b>Yes</b> / <b>No</b> ( <b>Pass Code = 011</b> )	Restore Factory Settings
	Manual Control	Pan	000-255	Manual Control
		Tilt	000-255	
		Color	000-255	
		Gobo	000-255	
RGobo		000-255		
Prism1		000-255		
RPrism1		000-255		
Prism2		000-255		
RPrism2		000-255		
Shutter		000-255		
Dimmer		000-255		
Frost		000-255		
Focus		000-255		

# SYSTEM MENU (Software Version >V1.0.4)

Menu	Submenu	Options	Description	
Information	Fixture Life Time	Power On Time: XXXXXX Hours	Total Running Time (Not Resettable)	
		P On Time-R: XXXXXX Hours	Total Running Time (Resettable)	
		P-On Time Reset: <b>Pass Code = 050</b>	Reset P-On Time-R (Total Running Time)	
	Total Lamp Time	Lamp On Time - XXXXXX Hours	Lamp On Time (Not Resettable)	
		Lamp On Time-R - XXXXXX Hours	Lamp On Time (Resettable)	
		Lamp On Time Reset: <b>Pass Code = 050</b>	Reset Lamp On Time-R (Lamp On Time)	
		LampLifeTime: XXX%	Current Lamp Life Percentage	
	Fixture Temps	Head	Current: XXX °F / XXX °C	Current Head Temperature
			Max Resettable: XXX °F / XXX °C	Maximum Temperature(1) Reached (Resettable) <b>(See Note 1)</b>
			Max Not Resettable: XXX °F / XXX °C	Maximum Temperature(2) Reached (Not Resettable) <b>(See Note 2)</b>
		Base	Current: XXX °F / XXX °C	Current Base Temperature
			Max Resettable: XXX °F / XXX °C	Maximum Temperature(1) Reached (Resettable) <b>(See Note 1)</b>
			Max Not Resettable: XXX °F / XXX °C	Maximum Temperature(2) Reached (Not Resettable) <b>(See Note 2)</b>
		Reset Head Temp: Yes / No <b>(Pass Code = 050)</b>	Reset Head Temperature (Max Resettable)	
	Reset Base Temp: Yes / No <b>(Pass Code = 050)</b>	Reset Base Temperature (Max Resettable)		
	Humidity	Head Humidity: XXX%	Current Head Humidity	
		Base Humidity: XXX%	Current Base Humidity	
	Fan Info. (RPM)	Base Fan 1: XXXX	Base Fan 1 Speed	
		Base Fan 2: XXXX	Base Fan 2 Speed	
		Base Fan 3: XXXX	Base Fan 3 Speed	
		Arm Fan 1: XXXX	Arm Fan 1 Speed	
		Arm Fan 2: XXXX	Arm Fan 2 Speed	
		Head Fan 1: XXXX	Head Fan 1 Speed	
		Head Fan 2: XXXX	Head Fan 2 Speed	
		Head Fan 3: XXXX	Head Fan 3 Speed	
		Head Fan 4: XXXX	Head Fan 4 Speed	
		Head Fan 5: XXXX	Head Fan 5 Speed	
		Head Fan 6: XXXX	Head Fan 6 Speed	
		Head Fan 7: XXXX	Head Fan 7 Speed	
	DMX Values(3) <b>(See Note 3)</b>	Pan, Pan Fine, Tilt, Tilt Fine, Color, Gobo, RGobo, Prism1, RPrism1, Prism2, RPrism2, Shutter, Dimmer, Focus, Frost, P/T Speed, & Spe. Func	Current DMX Values	
	Error Logs	Fixture Errors (Listed Errors One by One)	Last 10 Fixture Error Codes	
		Reset Error Log: Yes / No <b>(Pass Code = 050)</b>	Clear the Error Log	
	Software Version	X.XX	Current Software Version	

## SYSTEM MENU

Menu	Submenu	Options		Description
Lamp Control	Lamp ON / OFF	On / <b>Off</b>		Lamp On/Off
	Lamp ON with Power	On / <b>Off</b>		Lamp ON when Power ON
	Lamp ON via DMX	<b>On</b> / Off		Lamp Power ON via DMX
	Lamp OFF via DMX	<b>On</b> / Off		Lamp Power OFF via DMX

**Notes:**

- (1) **Current Maximum Temperature** - Maximum fixture temp. that has been recorded, before reset and after reset.
- (2) **Maximum Temperature** - Overall maximum fixture temp. that has been recorded. (Not Resettable)
- (3) **DMX Value options** depend on the DMX Channel mode the fixture is set to.

# SYSTEM MENU

**DMX SETTINGS** The submenus listed under **DMX SETTINGS** are as follows: **DMX Address**, **DMX Channel Mode**, **No DMX Status**, and **Select Signal**.

- **DMX ADDRESS** - In this submenu you can use the **UP** or **DOWN** buttons to adjust and find your desired DMX address.
- **DMX CHANNEL MODE** - In this submenu you can use the **UP** or **DOWN** buttons to find your desired DMX channel mode.
- **NO DMX STATUS** - This submenu setting is used as a precaution mode in case the DMX signal is lost or interrupted. The operating mode chosen in this submenu is the running mode the fixture will go into when the DMX signal is lost. Listed below are the 2 modes.
- **HOLD** - This setting will have the fixture stay in the last DMX setup.
- **BLACKOUT** - This setting will have the fixture automatically go into stand by mode.
- **MANUAL** - This setting will go into the current manual control set up. See **MANUAL CONTROL**.

**PERSONALITY** - The submenus listed under **PERSONALITY** are as follows: **Select Signal**, **Status Settings**, **WiFly Settings**, **Reset Motors**, **Display**, and **Service**.

- **SELECT SIGNAL** - In this submenu you can select your desired DMX control mode:
- **DMX** - Control the unit via DMX cable connection.
- **WiFly** - Control the unit via WiFly connection.
- **WiFly / DMX Out** - Control the unit via WiFly connection. The DMX signal is sent to the next unit via DMX cable.
- **STATUS SETTINGS** - In this submenu you are able to access and adjust/change: Pan Invert, Tilt Invert, P./T. Feedback, Pan Degree, P./T. Speed, and Hibernation.
- **WIFLY SETTINGS** - In this submenu you are able to access and adjust/change: WiFly Channel and Enable/Disable WiFly.
- **RESET MOTORS** - In this submenu you are able to reset selected motors.
- **DISPLAY** - In this submenu you are able to access and adjust/change: Backlight Intensity, Display Invert, Screen Saver Delay, and Display Lock.
- **SERVICE** - In this submenu you are able to access and adjust/change: the calibration (effect adjust) and restore the factory settings.

**MANUAL CONTROL** This menu is for manual testing and manual control. Pan, tilt, color wheel, gobo wheel, gobo rotation, prism 1, prism 1 rotation, prism 2, prism 2 rotation, shutter, dimmer, frost, and focus can all be tested/adjusted.

**INFORMATION** - The submenus listed under **INFORMATION** are as follows: **Fixture Life Time**, **Total Lamp Time**, **Fixture Temps**, **Humidity**, **Fan Info. (RPM)**, **DMX Values**, **Error Logs**, and **Software Version**.

## FIXTURE LIFE TIME

- **Power On Time** -The **TOTAL** power ON running time of the unit is displayed. This time **CANNOT** be reset. **Reminder: The displayed time represents the TOTAL POWER ON time.**
- **P-On Time-R** - The **CURRENT** power ON running time of the unit is displayed. This running time may not be the same as the total power ON running time displayed under “**Power On Time**”. This time **CAN** be reset. **Reminder: The displayed time represents the CURRENT POWER ON TIME since the last reset.**
- **P-On Time Reset** - Reset the **CURRENT** power ON running time that is displayed under “**P-On Time-R**”.

## TOTAL LAMP TIME

- **Lamp On Time** - The **TOTAL** Lamp ON time is displayed. This total lamp ON time **CANNOT** be reset. **Reminder: The displayed time represents the TOTAL LAMP ON time.**
- **Lamp On Time-R** - The **CURRENT LED ON** running time is displayed. This running time may not be the same as the total lamp ON time displayed under “**Lamp On Time**”. This total lamp ON time **CAN** be reset. **Reminder: The displayed time represents the CURRENT LAMP ON time since the last reset.**
- **Lamp On Time Reset** - With this function you can reset the **CURRENT** lamp ON time that is displayed under “**Lamp On Time-R**”.
- **LampLifeTime** - With this function you can check the current lamp life percentage.

# SYSTEM MENU

## FIXTURE TEMPS

- **Head**
  - Current** - Current temperature of the moving head is displayed.
  - Max Resettable** - Maximum moving head temperature that has been recorded, before reset and after reset. (Resettable)
  - Max Not Resettable** - Overall maximum moving head temperature that has been recorded. (**Not Resettable**)
- **Base**
  - Current** - Current temperature of the base is displayed.
  - Max Resettable** - Maximum base temperature that has been recorded, before reset and after reset. (**Resettable**)
  - Max Not Resettable** - Overall maximum moving head recorded temperature. (**Not Resettable**)
- **Reset Head Temp** - Reset the “**MAX RESETTABLE**” moving head temperature. (**Pass Code is “50”**)
- **Reset Base Temp** - Reset the “**MAX RESETTABLE**” base temperature. (**Pass Code is “50”**)
- **HUMIDITY**
  - Head Humidity** - The current humidity of the moving head is displayed.
  - Base Humidity** - The current humidity of the base is displayed.
- **FAN INFO. (RPM)**
  - Base Fan1** - Current speed of base fan 1 is displayed.
  - Base Fan2** - Current speed of base fan 2 is displayed.
  - Base Fan3** - Current speed of base fan 3 is displayed.
  - Arm Fan1** - Current speed of arm fan 1 is displayed.
  - Arm Fan2** - Current speed of arm fan 2 is displayed.
  - Head Fan1** - Current speed of moving head fan 1 is displayed.
  - Head Fan2** - Current speed of moving head fan 2 is displayed.
  - Head Fan3** - Current speed of moving head fan 3 is displayed.
  - Head Fan4** - Current speed of moving head fan 4 is displayed.
  - Head Fan5** - Current speed of moving head fan 5 is displayed.
  - Head Fan6** - Current speed of moving head fan 6 is displayed.
  - Head Fan7** - Current speed of moving head fan 7 is displayed.
- **DMX Values** - Displays the DMX values of any DMX channel that is currently in use.
- **Error Logs** - Displays any error codes.
- **Software Version** - Current software version is displayed.
- **LAMP CONTROL** - The submenus listed under **LAMP CONTROL** are as follows: **Lamp ON/OFF**, **Lamp ON with Power**, **Lamp ON via DMX**, and **Lamp OFF via DMX**.
- **Lamp ON/OFF** - Turn the lamp On/Off.
- **Lamp ON with Power** - Lamp powers “ON” when power is applied.
- **Lamp ON via DMX** - Power lamp “ON” using a DMX controller.
- **Lamp OFF via DMX** - Power lamp “OFF” using a DMX controller.

# WiFly CONTROL



**BEFORE SETTING THE WIRELESS CHANNEL ON ANY WIFLY FIXTURE, MAKE SURE THE SOURCE WIFLY WIRELESS DMX TRANSCEIVER DEVICE IS OFF.**

With this feature you are able to control the unit with DMX without the need of XLR cables. Your DMX controller must be connected to a ADJ WiFly Transceiver to use this function. You are able to communicate up to 2500 feet/760 meters (open line of sight).

1. Ensure the source **WiFly** wireless DMX Transceiver device is powered **OFF**.
2. Power **ON** the fixture and using the control panel scroll to the **PERSONALITY** menu and press **ENTER**. Use the **UP** and **DOWN** buttons to highlight the **WIFLY SETTINGS** submenu and press **ENTER**.
3. Using the **UP** and **DOWN** buttons, highlight **ENABLE/DISABLE WIFLY**. Press the **ENTER** button to toggle between **ENABLE & DISABLE**. Press **ENTER** so that “**Enable**” is displayed.
4. Next highlight **SET WIFLY CHANNEL** and press **ENTER**. Use the **UP** and **DOWN** buttons to find your desired WiFly address and press **ENTER** to confirm.

**NOTE:** Erratic fixture movement may occur if other **WiFly** wireless DMX products are in use in the same area and are using the same **WiFly** wireless channel. When **WiFly** is enabled, the fixture may immediately start to respond to the DMX wireless signal from another **WiFly** wireless DMX Transceiver. Make sure to know what **WiFly** wireless channels are being used in the area where the fixture is being used.

**ADJ WIFLY WIRELESS TRANSCEIVER only has 0-14 wireless channels, NO CH 15.**

5. Press the **MENU** button to exit out of the **WIFLY SETTINGS** submenu. Press the UP button so that **SELECT SIGNAL** is highlighted and press **ENTER**. Press the **DOWN** button to highlight **WIFLY** and press **ENTER**. Select **YES** and press **ENTER** to confirm.
6. Set your desired **DMX** address in the **DMX ADDRESS** submenu of the **DMX SETTINGS** main system menu. Set your desired DMX channel mode in the **DMX CH MODE** submenu of the **DMX SETTINGS** main system menu.
7. Repeat this process for all **WiFly** compatible fixtures in the **WiFly** wireless network, making sure all fixtures are assigned the same **WiFly** wireless channel
8. After all fixtures in the **WiFly** wireless network have been set to the same **WiFly** wireless channel and powered **ON**, power **ON** the source **WiFly** DMX Transceiver device.
9. Test all fixtures connected to the **WiFly** wireless network to confirm proper functionality.

## WIRELESS WIFLY INSTALLATION LOCATION GUIDELINES

For best results, position the fixture so that the display screen is oriented in the direction of the transmitter device or remote.

Wireless DMX signal can penetrate walls, glass, metal, and most objects. However, there are many factors that can affect and/or interrupt the wireless DMX signal, one of which is people. Therefore, it is highly recommended to position the wireless antenna a minimum of 9.8 ft. (3m) above audiences and/or above ground level. Careful planning and testing of the selected installation location is critical to ensure optimum and reliable wireless DMX operation.

9.8 ft (3m)  
Above Ground



# DMX TRAITS: CHANNEL FUNCTIONS & VALUES (15/17 DMX Channels)

15 Channels	17 Channels	Values	Functions
1	1	000-255	<b>PAN MOVEMENT 8-BIT:</b>
			Pan Movement (0° - 630°)
	2	000-255	<b>PAN FINE 16-BIT:</b>
			Fine Control of Pan Movement
2	3	000-255	<b>TILT MOVEMENT 8-BIT:</b>
			Tilt Movement (0° - 270°)
	4	000-255	<b>TILT FINE 16-BIT:</b>
			Fine Control of Tilt Movement
3	5		<b>COLOR WHEEL:</b>
		000-007	Open / White
		008-009	White + Red
		010-011	Red
		012-013	Red + Orange
		014-015	Orange
		016-017	Orange + Light Blue
		018-019	Light Blue
		020-021	Light Blue + Green
		022-023	Green
		024-025	Green + Light Green
		026-027	Light Green
		028-029	Light Green + Purple
		030-031	Purple
		032-033	Purple + Pink
		034-035	Pink
		036-037	Pink + Yellow
		038-039	Yellow
		040-041	Yellow + Magenta
		042-043	Magenta
		044-045	Magenta + Blue
		046-047	Blue
		048-049	Blue + Red/Green/Blue/Orange (Quad)
		050-051	Red/Green/Blue/Orange (Quad)
		052-053	Red/Green/Blue/Orange (Quad) + CTO-3200K
		054-055	CTO-3200K
		056-057	CTO-3200K + CTO-5600K
		058-059	CTO-5600K
		060-061	CTO-5600K + UV
		062-063	UV
		064-127	Color Wheel Indexing
		128-189	Clockwise Rotation Fast - Slow
190-193	Stop		
194-255	Clockwise Rotation Slow - Fast		



15 Channels	17 Channels	Values	Functions
4	6		<b>GOBO WHEEL</b>
		000-009	Open
		010-014	Gobo 1
		015-019	Gobo 2
		020-024	Gobo 3
		025-029	Gobo 4
		030-034	Gobo 5
		035-039	Gobo 6
		040-044	Gobo 7
		045-049	Gobo 8
		050-054	Gobo 9
		055-059	Gobo 10
		060-063	Gobo 11
		064-068	Open Shake
		069-073	Gobo 1 Shake
		074-078	Gobo 2 Shake
		079-083	Gobo 3 Shake
		084-088	Gobo 4 Shake
		089-093	Gobo 5 Shake
		094-098	Gobo 6 Shake
		099-103	Gobo 7 Shake
104-108	Gobo 8 Shake		
109-113	Gobo 9 Shake		
114-118	Gobo 10 Shake		
119-127	Gobo 11 Shake		
128-189	Clockwise Rotation Fast - Slow		
190-193	Stop		
194-255	Counter-Clockwise Rotation Slow - FastOpen		
5	7		<b>ROTATING GOBO:</b>
		000-127	Indexing
		128-189	Clockwise Rotation Fast - Slow
		190-193	Stop
		194-255	Counter-Clockwise Rotation Slow - Fast
6	8		<b>PRISM 1 (6 FACET LINEAR):</b>
		000-007	Close
		008-255	Open
7	9		<b>ROTATING PRISM 1 (6 FACET LINEAR):</b>
		000-127	Indexing
		128-189	Counter-Clockwise Rotation Fast - Slow
		190-193	Stop
		194-255	Clockwise Rotation Slow - Fast
8	10		<b>PRISM 2 (8 FACET CIRCULAR):</b>
		000-007	Close
		008-255	Open
9	11		<b>ROTATING PRISM 2 (8 FACET CIRCULAR):</b>
		000-127	Indexing
		128-189	Counter-Clockwise Rotation Fast - Slow
		190-193	Stop
		194-255	Clockwise Rotation Slow - Fast

15 Channels	17 Channels	Values	Functions
10	12		<b>SHUTTER &amp; STROBING:</b>
		000-031	Close
		032-063	Open
		064-095	Strobing Slow - Fast
		096-127	Open
		128-159	Pulsating Strobe Slow - Fast
		160-191	Open
		192-223	Random Strobing
		224-255	Open
11	13		<b>MASTER DIMMER:</b>
		000-255	0% - 100%
12	14		<b>FOCUS:</b>
		000-255	0% - 100%
			Frost
		000-007	Off
		008-255	On
14	16		<b>PAN/TILT MOVEMENT SPEED:</b>
		000-255	Fast - Slow
15	17		<b>SPECIAL FUNCTIONS:</b>
		000-069	No Function
		070-079	Blackout W/ Pan/Tilt Movement Enabled
		080-089	Blackout W/ Pan/Tilt Movement Disabled
		090-099	Blackout W/ Color Wheel Movement Enabled
		100-109	Blackout W/ Color Wheel Movement Disabled
		110-119	Blackout W/ Gobo Wheel Movement Enabled
		120-129	Blackout W/ Gobo Wheel Movement Disabled
		130-139	Lamp On
		140-149	Reset Pan & Tilt Motors
		150-159	Reset Effect Motors
		160-179	No Function
		180-189	Lamp Full Power
		190-199	Lamp Half Power
		200-209	Reset All
		210-229	No Function
230-239	Lamp Off		
240-255	No Function		

## ERROR CODES

#	Print Error Message	Description
1	Lamp Hot Power Off	Lamp Hot Power Off
2	CPU-B Error	CPU-B Error
3	CPU-C Error	CPU-C Error
4	CPU-D Error	CPU-D Error
5	CPU-E Error	CPU-E Error
6	Pan Reset Error	Pan :Reset Error
7	Pan Encoder Error	Pan : Encoder Error
8	Tilt Reset Error	Tilt :Reset Error
9	Tilt Encoder Error	Tilt : Encoder Error
10	Color Reset Error	Color :Reset Error
11	Gobo Reset Error	Gobo :Reset Error
12	RGobo Reset Error	RGobo :Reset Error
13	Prism1 Reset Error	Prism1 :Reset Error
14	RPrism1 Reset Error	RPrism1 :Reset Error
15	Prism2 Reset Error	Prism2 :Reset Error
16	RPrism2 Reset Error	RPrism2 :Reset Error
17	Focus Reset Error	Focus :Reset Error
18	Base Fan 1 start Errors	Base Fan 1 Can't Start
19	Base Fan 1 stop Errors	Base Fan 1 Can't Stop
20	Base Fan 1 Too Low Errors	Base Fan 1 speed Too low
21	Base Fan 1 Too High Errors	Base Fan 1 speed Too high
22	Base Fan 2 start Errors	Base Fan 2 Can't Start
23	Base Fan 2 stop Errors	Base Fan 2 Can't Stop
24	Base Fan 2 Too Low Errors	Base Fan 2 speed Too low
25	Base Fan 2 Too High Errors	Base Fan 2 speed Too high
26	Base Fan 3 start Errors	Base Fan 3 Can't Start
27	Base Fan 3 stop Errors	Base Fan 3 Can't Stop
28	Base Fan 3 Too Low Errors	Base Fan 3 speed Too low
29	Base Fan 3 Too High Errors	Base Fan 3 speed Too high
30	Side Fan 1 start Errors	Side Fan 1 Can't Start
31	Side Fan 1 stop Errors	Side Fan 1 Can't Stop
32	Side Fan 2 start Errors	Side Fan 2 Can't Start
33	Side Fan 2 stop Errors	Side Fan 2 Can't Stop
34	Lamp Fan 1 start Errors	Lamp Fan 1 Can't Start
35	Lamp Fan 1 stop Errors	Lamp Fan 1 Can't Stop
36	Lamp Fan 1 Too Low Errors	Lamp Fan 1 speed Too low
37	Lamp Fan 1 Too High Errors	Lamp e Fan 1 speed Too high

## ERROR CODES

#	Print Error Message	Description
38	Lamp Fan 2 start Errors	Lamp Fan 2 Can't Start
39	Lamp Fan 2 stop Errors	Lamp Fan 2 Can't Stop
40	Lamp Fan 2 Too Low Errors	Lamp Fan 2 speed Too low
41	Lamp Fan 2 Too High Errors	Lamp Fan 2 speed Too high
42	Lamp Fan 3 start Errors	Lamp Fan 3 Can't Start
43	Lamp Fan 3 stop Errors	Lamp Fan 3 Can't Stop
44	Lamp Fan 3 Too Low Errors	Lamp Fan 3 speed Too low
45	Lamp Fan 3 Too High Errors	Lamp Fan 3 speed Too high
46	Lamp Fan 4 start Errors	Lamp Fan 4 Can't Start
47	Lamp Fan 4 stop Errors	Lamp Fan 4 Can't Stop
48	Lamp Fan 4 Too Low Errors	Lamp Fan 4 speed Too low
49	Lamp Fan 4 Too High Errors	Lamp Fan 4 speed Too high
50	Lamp Fan 5 start Errors	Lamp Fan 5 Can't Start
51	Lamp Fan 5 stop Errors	Lamp Fan 5 Can't Stop
52	Lamp Fan 5 Too Low Errors	Lamp Fan 5 speed Too low
53	Lamp Fan 5 Too High Errors	Lamp Fan 5 speed Too high
54	Lamp Fan 6 start Errors	Lamp Fan 6 Can't Start
55	Lamp Fan 6 stop Errors	Lamp Fan 6 Can't Stop
56	Lamp Fan 6 Too Low Errors	Lamp Fan 6 speed Too low
57	Lamp Fan 6 Too High Errors	Lamp Fan 6 speed Too high
58	Lamp Fan 7 start Errors	Lamp Fan 7 Can't Start
59	Lamp Fan 7 stop Errors	Lamp Fan 7 Can't Stop
60	Lamp Fan 7 Too Low Errors	Lamp Fan 7 speed Too low
61	Lamp Fan 7 Too High Errors	Lamp Fan 7 speed Too high

## **MULTIPLE POWER LINKING**

With this feature you can connect the fixtures to one another using the power cable input and output sockets.

**NOTE: USE CAUTION WHEN POWER LINKING OTHER FIXTURES AS THE POWER CONSUMPTION OF OTHER MODEL FIXTURES MAY EXCEED THE MAX POWER OUTPUT ON THIS FIXTURE! CHECK SILK SCREEN FOR MAX AMPS.**

## **CLEANING**

Due to fog residue, smoke, and dust cleaning the internal and external optical lenses must be carried out periodically to optimize light output.

1. Use normal glass cleaner and a soft cloth to wipe down the outside casing.
2. Clean the external optics with glass cleaner and a soft cloth every 20 days.
3. Always be sure to dry all parts completely before plugging the unit back in.

Cleaning frequency depends on the environment in which the fixture operates (i.e. smoke, fog residue, dust, dew).

# SPECIFICATIONS

## Light Source:

- Lamp: Osram Sirius HRI 370W LL Long Life Discharge (Average Rated Life 1500 hours)
- Color Temperature : 8000K
- CRI: 70
- Beam Angle: 3-degrees

## Features:

- IP65 rated – protects from dust, sand, moisture, liquid
- Linear motorized focus
- Independent frost filter (wash effect)
- 0-100% smooth dimming
- Various strobe speeds
- Includes omega brackets
- Wifly EXR wireless DMX
- 8-facet circular prism
- 6-facet linear prism
- Antenna Range: 98.42ft (30m)

## Color Wheel:

- 11 colors + 3200K & 5600K + one Quad Color + open

## GOBO Wheel:

- 1 GOBO Wheel with 5 glass GOBOs, 3 metal GOBOs and 3 GOBO reducers + open
- All GOBOs rotate and are removable
- GOBOs outside diameter: 9.8mm
- GOBOs image diameter: 6.5mm
- GOBOs Thickness: 1.1mm Boro

## Construction:

- Display: Color
- Data In/Out: 5-pin DMX IP65 (with rubber protective covers over connections)
- Power In/Out: locking IP65 (with rubber protective covers over connections)
- Protection Rating: IP65
- All metal case design

## Control:

- 2 DMX Channel Modes: 15/17 Channels
- Control Mode: DMX512, RDM (Remote Device Management)
- With Wired Digital Communication Network

## Pan/Tilt:

- Pan/Tilt: 540/270
- Pan/Tilt Resolution; 16-bit

## Electrical:

- Power voltage: AC100-240V, 50/60Hz (Multi-voltage)
- Power consumption: 540W

## Dimensions & Weight:

- Dimension: 15.8" (L) x 16.5" (W) x 24.8" (H) / 401 x 419 x 629mm
- Weight: 64 lbs. / 29kg.

## Operating Temperature:

- Minimum operating temperature: -4°F (-20C)
- Maximum operating temperature: 104°F (40C)

## CERTIFICATIONS:

- cETLus Approved (Control #4000358)





# DIMENSIONS (VERTICAL)

