



# COB CANNON WASH ST COB CANNON WASH PEARL



## User Manual



©2022 ADJ Products, LLC all rights reserved. Information, specifications, diagrams, images, and instructions herein are subject to change without notice. ADJ Products, LLC logo and identifying product names and numbers herein are trademarks of ADJ Products, LLC. Copyright protection claimed includes all forms and matters of copyrightable materials and information now allowed by statutory or judicial law or hereinafter granted. Product names used in this document may be trademarks or registered trademarks of their respective companies and are hereby acknowledged. All non-ADJ Products, LLC brands and product names are trademarks or registered trademarks of their respective companies.

**ADJ Products, LLC** and all affiliated companies hereby disclaim any and all liabilities for property, equipment, building, and electrical damages, injuries to any persons, and direct or indirect economic loss associated with the use or reliance of any information contained within this document, and/or as a result of the improper, unsafe, insufficient and negligent assembly, installation, rigging, and operation of this product.

## DOCUMENT VERSION



Due to additional product features and/or enhancements, an updated version of this document may be available online.

Please check [www.adj.com](http://www.adj.com) for the latest revision/update of this manual before beginning installation and/or programming.

Date	Document Version	Software Version	DMX Channels	Notes
08/20/18	1.0	1.0	3 / 4 / 6 / 7 / 8 / 8A / 10 / 11 Ch.	Initial Release.
11/24/21	1.1	N/C	No Change	Updated UC IR Control.
11/29/21	1.2	N/C	No Change	Corrected Multi Unit Power Linking and Frequently Asked Questions
04/01/22	1.3	1.01	No Change	Updated primary/secondary

### Europe Energy Saving Notice

Energy Saving Matters (EuP 2009/125/EC)

Saving electric energy is a key to help protecting the environment. Please turn off all electrical products when they are not in use. To avoid power consumption in idle mode, disconnect all electrical equipment from power when not in use. Thank you!

## TABLE OF CONTENTS

FCC Statement	4
General Information	5
Limited Warranty (USA Only)	6
Safety Guidelines	7
Maintenance Guidelines	9
Overview	10
DMX Setup	11
Installation Instructions	13
System Menu	15
UC IR/Airstream Control	19
DMX Traits	21
Dimmer Curve Chart	28
Multi Unit Power Linking   Primary-Secondary Setup	29
Cleaning and Maintenance   Trouble Shooting Tips	30
Frequently Asked Questions   Optional Accessories	31
Specifications	32
Dimensional Drawings	33

## **FCC STATEMENT**

This device complies with Part 15 of the FCC Rules. Operation is subject to the following two conditions: (1) this device may not cause harmful interference, and (2) this device must accept any interference received, including interference that may cause undesired operation.

### **FCC RADIO FREQUENCY INTERFERENCE WARNINGS & INSTRUCTIONS**

This product has been tested and found to comply with the limits as per Part 15 of the FCC Rules. These limits are designed to provide reasonable protection against harmful interference in a residential installation. This device uses and can radiate radio frequency energy and, if not installed and used in accordance with the included instructions, may cause harmful interference to radio communications. However, there is no guarantee that interference will not occur in a particular installation. If this device does cause harmful interference to radio or television reception, which can be determined by turning the device off and on, the user is encouraged to try to correct the interference by one or more of the following methods:

- Reorient or relocate the device.
- Increase the separation between the device and the receiver.
- Connect the device and the radio received to electrical outlets on different electrical circuits.
- Consult the dealer or an experienced radio/TV technician for help.



## GENERAL INFORMATION

**Introduction:** Please read and understand all instructions in this manual carefully and thoroughly before attempting to operate these products. These instructions contain important safety and use information.

**Unpacking:** The products in this kit have been thoroughly tested and have been shipped in perfect operating condition. Carefully check the shipping carton for damage that may have occurred during shipping. If the carton appears to have been damaged, carefully inspect the unit for damage and be sure all accessories necessary to operate the unit has arrived intact. In the event that damage has been found or parts are missing, please contact our customer support team for further instructions. Please do not return this kit to your dealer without first contacting customer support at the number listed below. Please do not discard the shipping carton in the trash. Please recycle whenever possible.

**Warranty Returns:** All returned service items, whether under warranty or not, must be freight pre-paid and accompanied by a return authorization (R.A.) number. The R.A. number must be clearly written on the outside of the return package. A brief description of the problem as well as the R.A. number must also be written down on a piece of paper and included in the shipping container. If the unit is under warranty, you must provide a copy of your proof of purchase invoice. Items returned without an R.A. number clearly marked on the outside of the package will be refused and returned at customer's expense. You may obtain an R.A. number by contacting customer support.

### **ADJ PRODUCTS LLC USA**

6122 S. Eastern Ave. Los Angeles, CA 90040  
323-582-2650 | Fax 323-532-2941 | [www.adj.com](http://www.adj.com) | [info@adj.com](mailto:info@adj.com)

### **ADJ SUPPLY Europe B.V**

Junostraat 2 6468 EW Kerkrade, The Netherlands  
+31 (0)45 546 85 00 | Fax +31 45 546 85 99 | [www.americandj.eu](http://www.americandj.eu) | [info@americandj.eu](mailto:info@americandj.eu)

### **ADJ PRODUCTS GROUP Mexico**

AV Santa Ana 30 Parque Industrial Lerma, Lerma, Mexico 52000  
+52 (728) 282-7070 | [ventas@adj.com](mailto:ventas@adj.com)

### **CUSTOMER SUPPORT**

Contact ADJ Service for any product related service and support needs.  
Please visit [forums.adj.com](http://forums.adj.com) with questions, comments, or suggestions.

### **ADJ SERVICE USA - Monday - Friday 8:00am to 4:30pm PST**

800-322-6337 | Fax 323-832-2941 | [support@adj.com](mailto:support@adj.com)

### **ADJ SERVICE EUROPE - Monday - Friday 08:30 to 17:00 CET**

+31 45 546 85 60 | Fax +31 45 546 85 96 | [support@adj.eu](mailto:support@adj.eu)

**REPLACEMENT PARTS** please visit [parts.adj.com](http://parts.adj.com)

## LIMITED WARRANTY (USA ONLY)

- A. ADJ Products, LLC hereby warrants, to the original purchaser, ADJ Products, LLC products to be free of manufacturing defects in material and workmanship for a prescribed period from the date of purchase (see specific warranty period on reverse). This warranty shall be valid only if the product is purchased within the United States of America, including possessions and territories. It is the owner's responsibility to establish the date and place of purchase by acceptable evidence, at the time service is sought.
- B. For warranty service, you must obtain a Return Authorization number (RA#) before sending the product back—please contact ADJ Products, LLC Service Department at 800-322-6337. Send the product only to the ADJ Products, LLC factory. All shipping charges must be prepaid. If the requested repairs or service (including parts replacement) are within the terms of this warranty, ADJ Products, LLC will pay return shipping charges only to a designated point within the United States. If the entire instrument is sent, it must be shipped in its original package and packaging material. No accessories should be shipped with the product. If any accessories are shipped with the product, ADJ Products, LLC shall incur no liability whatsoever for loss of or damage to any such accessories, nor for the safe return thereof.
- C. This warranty is void if the product serial number and/or labels are altered or removed; if the product is modified in any manner which ADJ Products, LLC concludes, after inspection, affects the reliability of the product; if the product has been repaired or serviced by anyone other than the ADJ Products, LLC factory unless prior written authorization was issued to purchaser by ADJ Products, LLC; if the product is damaged because it was not properly maintained as set forth in the product instructions, guidelines and/or user manual.
- D. This is not a service contract, and this warranty does not include maintenance, cleaning, or periodic checkup. During the period specified above, ADJ Products, LLC will replace defective parts at its expense with new or refurbished parts, and will absorb all expenses for warranty service and repair labor by reason of defects in material or workmanship. The sole responsibility of ADJ Products, LLC under this warranty shall be limited to the repair of the product, or replacement thereof, including parts, at the sole discretion of ADJ Products, LLC. All products covered by this warranty were manufactured after August 15, 2012, and bear identifying marks to that effect.
- E. ADJ Products, LLC reserves the right to make changes in design and/or improvements upon its products without any obligation to include these changes in any products theretofore manufactured.
- F. No warranty, whether expressed or implied, is given or made with respect to any accessory supplied with products described above. Except to the extent prohibited by applicable law, all implied warranties made by ADJ Products, LLC in connection with this product, including warranties of merchantability or fitness, are limited in duration to the warranty period set forth above. And all warranties, whether expressed or implied, including warranties of merchantability or fitness, are limited in duration to the warranty period set forth above. The consumer's and/or dealer's sole remedy shall be such repair or replacement as is expressly provided above; and under no circumstances shall ADJ Product, LLC be liable for any loss and/or damage, direct and/or consequential arising out of the use of, and/or inability to use this product.
- G. This warranty is the only written warranty applicable to ADJ Products, LLC products, and supersedes all prior warranties and written descriptions of warranty terms and conditions heretofore published.

### MANUFACTURER'S LIMITED WARRANTY PERIODS:

- Non-LED Lighting Products = 1-Year (365 Days) (Including Special Effect Lighting, Intelligent Lighting, UV lighting, Strobes, Fog Machines, Bubble Machines, Mirror Balls, Par Cans, Trussing, Lighting Stands, Power/Data Distribution, etc. excluding LED and lamps)
- Laser Products = 1-Year (365 Days) (excluding laser diodes which have a 6-Month Limited Warranty)
- LED Products = 2-Year (730 Days) (excluding batteries which have a 180 Day Limited Warranty)
- NOTE: 2-Year (730 Days) Limited Warranty ONLY applies to product purchased within the United States. StarTec Series = 1-Year (365 Days) (excluding batteries which have a 180 Day Limited Warranty)
- ADJ DMX Controllers = 2 Year (730 Days)
- American Audio Products = 1 Year (365 Days)

## SAFETY GUIDELINES

To guarantee smooth operation, it is important to follow all instructions and guidelines in this manual. ADJ PRODUCTS LLC is not responsible for injury and/or damages resulting from the misuse of these devices due to the disregard of the information printed in this manual. Only qualified and/or certified personnel should perform installation of these devices, and only the original rigging parts included with these devices should be used for installation. Any modifications to these devices and/or the included mounting hardware will void the original manufacturer's warranty and increase the risk of damage and/or personal injury.



### **PROTECTION CLASS 1 – DEVICES MUST BE PROPERLY GROUNDED**



**THERE ARE NO USER SERVICEABLE PARTS INSIDE THESE DEVICES. DO NOT ATTEMPT ANY REPAIRS YOURSELF, AS DOING SO WILL VOID YOUR MANUFACTURER'S WARRANTY. DAMAGES RESULTING FROM MODIFICATIONS TO THESE DEVICES AND/OR THE DISREGARD OF SAFETY INSTRUCTIONS AND GUIDELINES IN THIS MANUAL VOID THE MANUFACTURER'S WARRANTY AND ARE NOT SUBJECT TO ANY WARRANTY CLAIMS AND/OR REPAIRS.**



**DO NOT PLUG THIS UNIT INTO A DIMMER PACK!  
DO NOT REMOVE THE COVER FOR ANY REASON!  
NEVER OPERATE THIS UNIT WITH THE COVER REMOVED!  
UNPLUG POWER DURING LONG PERIODS OF NON-USE  
NEVER TOUCH LIGHT DURING OPERATION, AS SURFACE MAY BE HOT!  
KEEP FLAMMABLE MATERIALS AWAY FROM THESE DEVICES!  
DO NOT EXCEED OPERATING TEMPERATURES OF 185°F (85°C)!**



**INDOOR / DRY LOCATIONS USE ONLY!  
DO NOT EXPOSE DEVICES TO RAIN AND/OR MOISTURE!**

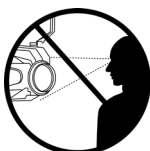

**NEVER LOOK DIRECTLY INTO THE LIGHT SOURCE!  
RETINA INJURY RISK - MAY INDUCE BLINDNESS!  
SENSITIVE PERSONS MAY SUFFER AN EPILEPTIC SHOCK!**

## **SAFETY GUIDELINES**

- DO NOT position devices close to any FLAMMABLE MATERIALS during operation.
- DO NOT attempt installation and/or operation of devices without knowledge how to do so.
- DO NOT permit operation by persons who are not qualified to operate these types of devices.
- DO NOT shake devices, and avoid brute force when installing and/or operating.
- DO NOT operate these devices if the main power cord has become frayed, crimped, and/or damaged. Replace any damaged power cords with new cords of the same power rating.
- DO NOT disassemble devices. There are NO user serviceable parts inside.
- ALWAYS disconnect devices from main power source before performing any cleaning.
- ALWAYS disconnect light from main power before replacing lamp.
- ALWAYS be sure to install these devices in an area that will allow proper ventilation.
- NEVER remove the ground prong from the power cable.
- Power cords should be safely routed and secured so they are not likely pinched.
- Disconnect power cords during long periods of non-use.
- Only use recommended rigging hardware as described in this guide.
- Use the original packaging and materials to transport these devices in for service.
- These devices should be serviced by qualified service personnel when:
  - A. The power cords or plugs have been damaged.
  - B. Objects have fallen on and/or liquid has spilled into the devices.
  - C. The devices have been exposed to rain and/or moisture.
  - D. The devices do not operate normally or exhibit a marked change in performance.



## MAINTENANCE GUIDELINES



**DISCONNECT POWER BEFORE PERFORMING ANY MAINTENANCE!**

### **CLEANING**

Frequent cleaning is recommended to ensure proper function, optimized light output, and an extended life. The frequency of cleaning depends on the environment in which the devices operates: damp, smoky, or particularly dirty environments can cause greater accumulation of dirt on the mirror ball and/or light fixture optics. Periodically clean the external lens of the mirror ball surface and the front lens of the light with a soft cloth to avoid dirt/debris accumulation

**NEVER** use alcohol, solvents, or ammonia-based cleaners.

### **MAINTENANCE**

Regular inspections are recommended to ensure proper function and extended life. There are no user serviceable parts inside these devices. Please refer all other service issues to an authorized ADJ service technician. Should you need any spare parts, please order genuine parts from your local ADJ dealer.

Please refer to the following points during routine inspections:

- A detailed review by an approved electrical engineer every three months, to make sure the circuit contacts are in good condition and prevent overheating.
- Be sure all screws and fasteners are securely tightened at all times. Loose screws may fall out during normal operation, resulting in damage or injury as larger parts could fall.
- Check for any deformations on the light, light housings, lenses, rigging hardware, and rigging points (ceiling, suspension, trussing). Deformations could allow for dust to enter into the devices. Damaged rigging points or unsecured rigging could cause the devices to fall and seriously injure a person(s).
- Electric power supply cables must not show any damage, material fatigue, or sediments.

## OVERVIEW

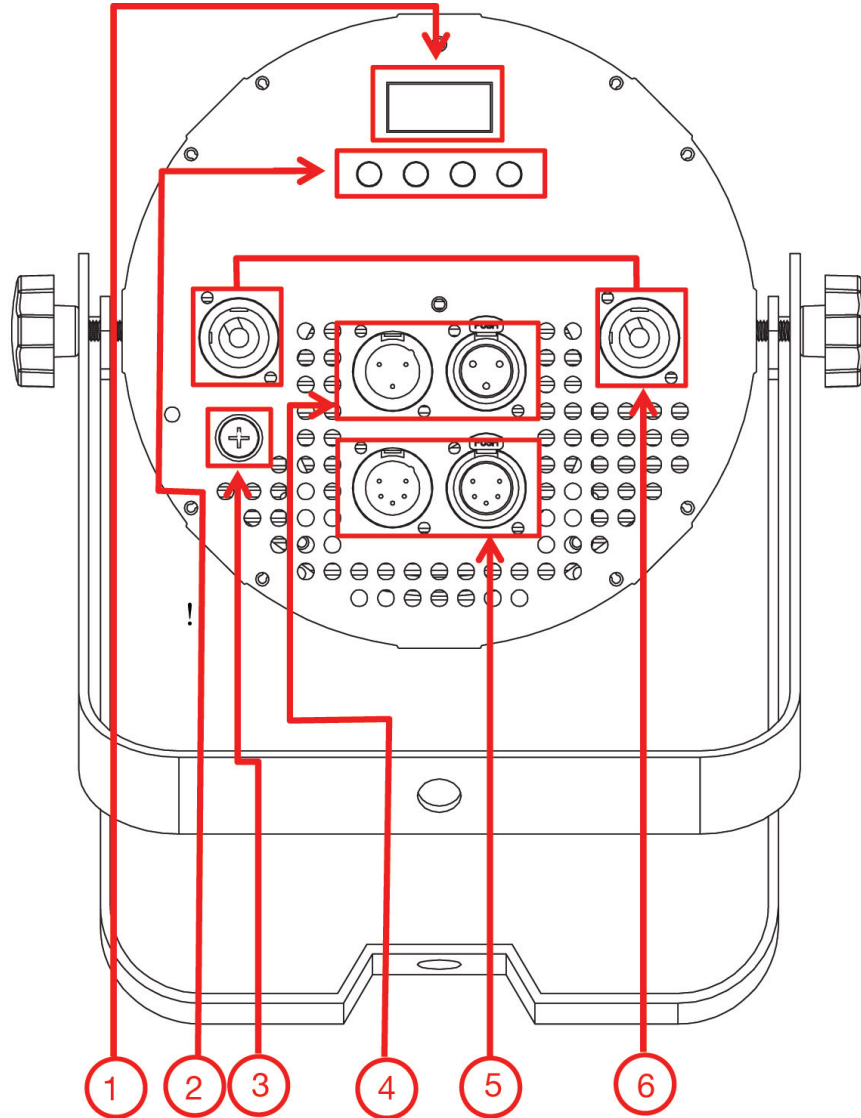

1. **Display:** Show the various menus and the selected functions.
2. **Button:**

MENU	Scroll through available functions
SET UP	Select and configure function
UP	Go backward in selected function
DOWN	Go forward in selected function

3. **Fuse:** 3 Amps
4. **DMX Input/Output:** 3-pin In/Out Connection
5. **DMX Input/Output:** 5-pin In/Out Connection
6. **Main Input/Output:** Power main connection

# DMX SETUP

## POWER SUPPLY

The COB Cannon Wash ST contains an automatic voltage switch, which will automatically sense the voltage when it is plugged into the power source. With this switch, there is no need to worry about the correct power voltage, and this unit can be plugged in anywhere.

## DMX-512

DMX is short for Digital Multiplex. This is a universal protocol used by most lighting and controller manufacturers as a form of communication between intelligent fixtures and controllers. A DMX controller sends DMX data instructions from the controller to the fixture. DMX data is sent as serial data that travels from fixture to fixture via the DATA “IN” and DATA “OUT” XLR terminals located on all DMX fixtures (most controllers only have a DATA “OUT” terminal).

## DMX LINKING

DMX is a language allowing all makes and models of different manufacturers to be linked together and operate from a single controller, as long as all fixtures and the controller are DMX compliant. To ensure proper DMX data transmission, try to use the shortest cable path possible when linking several DMX fixtures. The order in which fixtures are connected in a DMX line does not influence the DMX addressing. For example, a fixture assigned a DMX address of 1 may be placed anywhere in a DMX line: at the beginning, at the end, or anywhere in the middle. Therefore, the first fixture controlled by the controller could be the last fixture in the chain. When a fixture is assigned a DMX address of 1, the DMX controller knows to send DATA assigned to address 1 to that unit, no matter where it is located in the DMX chain.

## DATA CABLE (DMX CABLE) REQUIREMENTS (FOR DMX AND PRIMARY/SECONDARY OPERATION):

The COB Cannon Wash ST can be controlled via DMX-512 protocol. The COB Cannon Wash ST has eight DMX channel modes (3-channel, 4-channel, 6-channel, 7-channel, 8-channel, 8A-channel, 10-channel, or 11-channel mode). The DMX address is set electronically using the controls on the rear panel of the unit. Your unit and your DMX controller require an approved DMX-512 110 Ohm Data cable for data input and data output (Figure 1). We recommend AccuCable DMX cables. If you are making your own cables, be sure to use standard 110-120 Ohm shielded cable (This cable be purchased at almost all professional sound and lighting stores). Your cables should be made with a male XLR connector at one end and a female XLR connector at the other. Also remember that DMX cable must be daisy chained and cannot be split.



Figure 1

# DMX SETUP

## NOTICE

Be sure to follow figures two and three when making your own cables. Do not use the ground lug on the XLR connector. Do not connect the cable's shield conductor to the ground lug or allow the shield conductor to come in contact with the XLR's outer casing. Grounding the shield could cause a short circuit and result in erratic behavior.

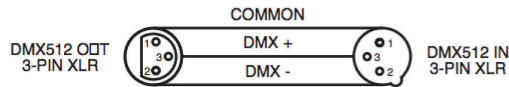

Figure 2

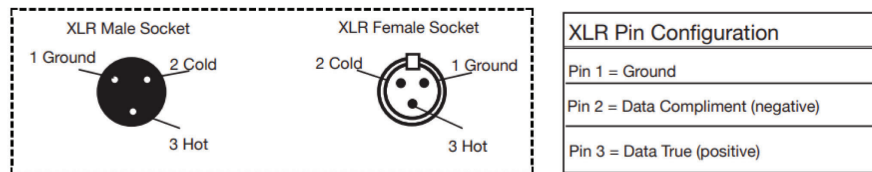

Figure 3

## SPECIAL NOTE: LINE TERMINATION

When longer runs of cable are used, you may need to use a terminator on the last unit to avoid erratic behavior. A terminator is a 110-120 ohm 1/4 watt resistor, which is connected between pins 2 and 3 of a male XLR connector (DATA + and DATA -). This unit is inserted in the female XLR connector of the last unit in your daisy chain to terminate the line. Using a cable terminator (ADJ part number Z-DMX/T) will reduce the risk of erratic behavior.

Figure 4

DMX512 IN  
3-PIN XLR

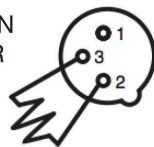

Termination reduces signal errors and avoids signal transmission problems and interference. It is always advisable to connect a DMX terminal, (Resistance 120 Ohm 1/4 W) between PIN 2 (DMX-) and PIN 3 (DMX +) of the last fixture.

Figure 4

# INSTALLATION INSTRUCTIONS

## INSTALLATION

This unit should be mounted using a mounting clamp (not provided), affixing it to the mounting bracket that is provided with the unit. Always ensure that the unit is firmly fixed to avoid vibration and slipping while operating. Always ensure that the structure to which you are attaching the unit is secure and is able to support at least ten (10) times the weight of the unit plus any mounting accessories. A safety cable (optional) is required when installing the fixture. It is also recommended that a professional installs the equipment, and that the unit be installed in a place where it is out of the reach of people's grasp.

The unit is capable of being mounted in any of the orientations shown in the diagram below:

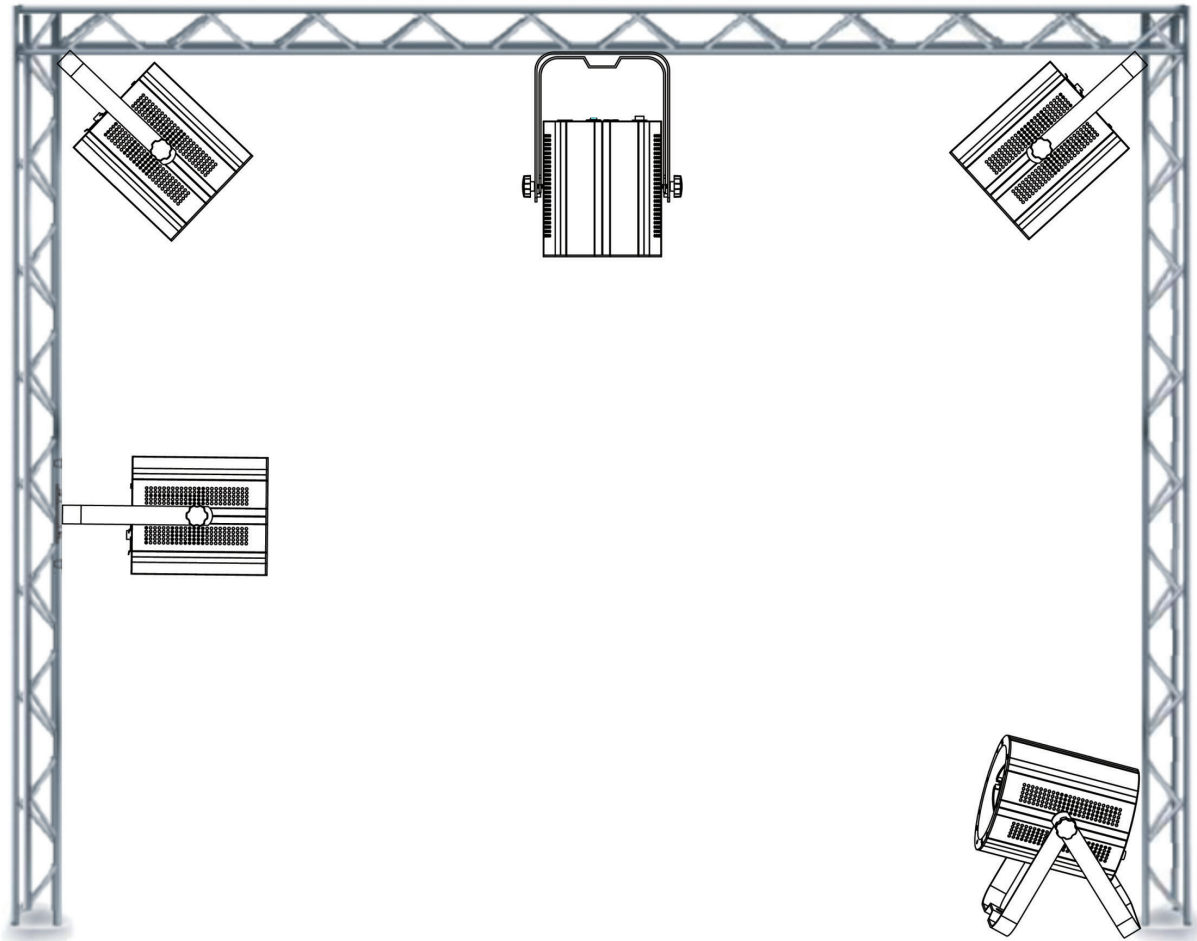

## INSTALLATION INSTRUCTIONS

### OPTIONAL LENS CHANGE

The COB Cannon Wash ST comes with an 80-degree lens already attached. Included in the box are optional 40 & 50-degree lenses. To switch lenses, follow the steps below:

1. Remove the retainer ring located in front of the current lens.
2. Carefully remove the lens, and attach your desired lens.
3. Reinstall the retainer ring. The switch is now complete.

**Note:** When reinstalling the retainer ring, make sure to insert 3 points of the retainer ring into the 3 notches located around the inside of the lens frame.

## SYSTEM MENU

### MODES

The COB Cannon Wash ST has 7 modes: DMX Mode, SEcd Mode, Manual Dimmer Color Mode, Sound Active Mode, Auto Run Program Mode and Static Color Select Mode.

During operation, the display will lock after 30 seconds. To unlock the display, press and hold the MODE button for 3 seconds.

MODE	SETUP	UP/DOWN	DESCRIPTION
DMX	d.xxx	d.001 ~ d.512	Set the DMX starting address
	Channels	Ch03	Select DMX channel mode
		Ch04	
		Ch06	
		Ch07	
		Ch08	
		Ch8A	
		Ch10	
	No DMX Mode	blAc	Unit switches all LEDs off when DMX signal is lost or interrupted
		LAST	Unit holds last state when DMX signal is lost or interrupted
ProG		Unit runs internal programs when DMX signal is lost or interrupted	
dr-x	dr-0 ~ dr-5	Select unit delay mode	
SEcd	SEcd	Set unit to secondary mode	
DIMMER	r.xxx	r.000 ~ r.255	Adjust red intensity
	G.xxx	G.000 ~ G.255	Adjust green intensity
	b.xxx	b.000 ~ b.255	Adjust blue intensity
	A.xxx	A.000 ~ A.255	Adjust amber intensity
	FS.xx	FS.00 ~ FS.15	Adjust flash speed; FS.00 is flash off, FS.01 is slowest, FS.15 is fastest
SOUND	Soxx	So01 ~ So16	Select from the 16 built-in sound modes
	SJ-x	SJ-1 ~ SJ-8	Adjust sound sensitivity level; SJ-1 is lowest, and SJ-8 is highest

CONTINUED ON NEXT PAGE

## SYSTEM MENU

MODE	SETUP	UP/DOWN	DESCRIPTION
AUTO RUN	AFxx	AF01 ~ AF16	Select from 16 built-in dreaming mode settings
	AJxx	AJ01 ~ AJ16	Select from 16 built-in jumping mode settings
	A-JF		Set unit to auto dreaming & jumping mode; unit will now run through dreaming mode and jumping mode in a continuous cycle
	Sp.xx	Sp.01 ~ Sp.16	Adjust speed of the dreaming/jumping mode
STATIC COLOR SELECT	CLxx	CL00 ~ CL64	Select from 64 static color options
	FS.xx	FS.00 ~ FS.15	Adjust flash speed: FS.00 is flash off, FS.01 is slowest, FS.15 is fastest
OTHER	don / doff		LED display always on (don) or display off (doff)
	Iron / Iroff		IR remote function on (Iron) or off (Iroff)
	Stnd / rev		Digital display orientation: standard (Stnd) or inverted (rev)
	dEFA		Initialize the unit at factory settings



## SYSTEM MENU

**DMX Mode:** Operating through a DMX controller gives the user the freedom to create their own programs tailored to their own individual needs. See the **DMX Traits** section of this manual for detailed information. Press the MODE button to select the DMX mode.

**DMX Addressing and Channel Mode:** This function will allow you to control each individual fixture's traits with a standard DMX 512 controller. (When a DMX Address is set, the LED display will flicker if there is no signal from the controller.)

1. To run your fixture in DMX mode, press the MODE button until "d.XXX" is displayed. "XXX" represents the current selected DMX address.
2. Use the UP or DOWN buttons to select your desired DMX address, then press the SET UP button to select your DMX Channel mode.
3. Use the UP or DOWN button to scroll through the DMX Channel modes (Ch03, Ch04, Ch05, Ch06, Ch07, Ch08, Ch8A, Ch10 and Ch11).

**No DMX Setup:** This mode allows the unit to default to one of three modes if the DMX signal is lost or interrupted

1. Press the SET UP button to select your setting.
2. Press the UP or DOWN button to select one of the three options.
  - BLACKOUT = "bIAc". The unit will switch all LED's off if signal is lost.
  - HOLD = "LAsT". The unit will hold the last state before the signal was lost.
  - AUTO = "ProG". The unit will run the default internal programs.

**Delay Mode:** Select the unit delay mode by pressing the SET UP button until "dr-X" is displayed. Press the Up or Down button to set the delay rate 0-5. After you have chosen your desired DMX Channel mode, plug in the fixture via the XLR connections to any standard DMX controller.

**Secondary Mode:** Press the MODE button to select the Secondary mode.

Secondary mode will be displayed as "SEcd".

*Note:* While in Secondary mode, the SET UP, UP, and DOWN buttons will not function.

**Manual Dimmer Color Mode:** Press the MODE button to select the Manual Dimmer Color mode. The Color Red will be displayed as "r.XXX" with "XX" representing the dimming rate of 0-255.

1. Press the SET UP button to select a different color; green "GXXX", blue "bXXX", or amber "AXXX".
2. Press the Up or Down button to set the dimming rate 0-255.

**Flash Speed Select:** Press MODE button to select the Flash Speed Select mode. Flash Speed will be displayed as "FS.XX" with "XX" representing the flash speed rate.

1. Press the SET UP button to adjust the desired flash speed.
2. Press the Up or Down button to set the speed between "FS.00" (flash off), "FS.01" (slowest flash) and "FS.15" (fastest flash).

## SYSTEM MENU

**Sound Active Mode:** In this mode, the COB Cannon Wash ST will react to sound, and chase through the different colors. Press MODE button to select the Sound Active mode. Sound Active mode will be displayed as “SoXX” with “XX” representing Sound Active mode (1-8).

1. Press the SET UP button to adjust the sound sensitivity. “SJ-X” should be displayed.
2. Press the UP or DOWN button to adjust the sensitivity level from 1 (off) to 8 (highest).

**Auto Run Program Mode:** There are 3 types of Auto Run Modes to choose from: Color Fade, Color Change, and both modes running together. The running speed is adjustable in all 3 modes. Press the MODE button until “AFXX”, “AJXX”, or “A-JF” is displayed.

- Color Fade Mode (AFxx): Choose from 16 color fade modes. Use the UP and DOWN buttons to scroll through the different modes.
- Color Change Mode (AJxx): Choose from 16 color change modes. Use the UP and DOWN buttons to scroll through the different modes.
- Both Color Fade and Color Change Modes (A-JF).

After you have chosen your desired running mode, press the SET UP button until “SP.XX” is displayed. When this is displayed you can adjust the running speed of your desired program. Use the UP or DOWN button to adjust the speed between “SP.01” (slowest) and “SP.16” (fastest). Once you have set your desired running speed, press the SET UP button to return to your desired Auto Run Mode.

**Static Color Select Mode:** Choose between 64 static colors and activate/deactivate strobe.

1. Press MODE button to select the Static Color Select mode.
2. Press the SET UP button until “CLXX” or “FSXX” is displayed.
  - Static Color Mode = “CLXX”. There are 64 static colors to choose from. Use the UP or DOWN button to select desired static color.
  - Flash Speed Select = “FS.XX”. Use the UP or DOWN button to adjust between “FS.00” (flash off), and “FS.01” (slowest flash) to “FS.15” (fastest flash).

**Other Program Select Mode:** There are 4 “Other” setup features to adjust. LED Display On/Off, IR Remote On/Off, Display Inversion, and Initialization. Press the MODE button until “doXX”, “IrXX”, “Stnd” or “dEFA” is displayed.

- LED Display On/Off = “doXX”. Set the LED display to turn off after 60 seconds by pressing UP or DOWN button to display “doff”. The display will turn off after 60 seconds and will reappear with the press of a button. Be advised that it will turn off again automatically after 60 seconds of inactivity. Selecting “don “ will set the LED display to On at all times.
- IR Remote Function On/OFF = “IrXX”. Press UP or DOWN button to display “Iron” to enable IR remote function or to “IroF” to disable IR remote function.
- LED Display Inversion = “Stnd”. Press UP or DOWN button to invert to display 180 degrees.
- Initialization select mode = “dEFR”. Press the UP and DOWN buttons simultaneously to restore all modes to default settings. Press the MODE button to exit.

## UC IR/AIRSTREAM CONTROL

### WIRELESS SETUP

There are many factors that can affect and/or interrupt a wireless signal, including walls, glass, metal, objects, and people. Therefore, the following guidelines are recommended in order to maximize the chances of having a clear path for the wireless signal to reach the device:

- Install the device a minimum of 9.8 ft (3m) above audiences and/or ground level.
- Arrange the wireless antenna in an upright, vertical position.
- Position devices in direct line of sight of the transmitting controller.

Careful planning and testing of the selected installation location is critical to ensure optimum and reliable wireless operation.

9.8 ft (3m)  
Above Ground



### UC IR REMOTE

The unit should respond to commands issued from the UC IR Remote. **NOTE: The unit can only be controlled when it has been set to Primary mode. The unit will NOT respond to commands when it has been set to Secondary mode.**



## UC IR/AIRSTREAM CONTROL

### WIRELESS FUNCTIONS

The UC IR (sold separately) infrared remote gives you control of various functions (See below). To control the fixture you must aim the remote at the front of the fixture and be no more than 30 feet away.

**Airstream IR (sold separately):** The remote transmitter plugs into the headphone jack of your iOS phone or tablet. To control your IR fixture, you must raise the volume to the maximum on your iOS phone or tablet and aim the transmitter at the fixture sensor. Maximum operating range is 15 feet. After you have purchased the Airstream IR transmitter, the app is a free download from the app store for your iOS phone or tablet. The app comes with 3 pages of control depending on the fixture you are using. Please see the information below for the IR Functions in the corresponding app page.

*Works with App Page 1.*

**UC IR Remote Controls:** The UC IR Remote can only be used if “IR Remote Function” is set to “On” (see the **System Menu** section of this manual for detailed instructions on enabling IR Remote Function).

- **STAND BY** - Pressing this button will blackout the fixture. Press the button again to return to the initial state.
- **FULL ON:** Press this button to fully light up the unit.
- **FADE/GOBO:** Press this button to switch between Color Fade, Color Change, and Auto Run mode.
- **DIMMER + / DIMMER -:** Use to adjust the color output intensity when color mode is active.
- **STROBE:** Press this button for strobing, then press button ‘1’ to select slow strobe speed, button ‘2’ to select medium strobe speed, button ‘3’ to select fast strobe speed, or button ‘4’ to select faster strobe speed.
- **COLOR:** Press this button to activate color mode. Use buttons 1-9 to select your desired color.
- **1-9 BUTTONS:** Use buttons 1-4 to select your desired strobe speed when strobe mode is active. Use buttons 1-9 to select your desired color when color mode is active or your desired show when show mode is active.
- **SOUND ON / SOUND OFF:** Use the buttons to activate and deactivate sound active mode.
- **SHOW 0:** Press this button to select Show mode, then use buttons 1-9 to select Shows 1-9. Press the “Show 0” button twice to run Show #10, and press button ‘1’ twice to run show #11.

## DMX TRAITS

CHANNEL								DMX VALUES	FUNCTION
3-CH	4-CH	6-CH	7-CH	8-CH	8A-CH	10-CH	11-CH		
1									<b><i>Color Macros</i></b>
								000	Off
								001 - 004	Color Macro 01
								005 - 008	Color Macro 02
								009 - 012	Color Macro 03
								013 - 016	Color Macro 04
								017 - 020	Color Macro 05
								021 - 024	Color Macro 06
								025 - 028	Color Macro 07
								029 - 032	Color Macro 08
								033 - 036	Color Macro 09
								037 - 040	Color Macro 10
								041 - 044	Color Macro 11
								045 - 048	Color Macro 12
								049 - 052	Color Macro 13
								053 - 056	Color Macro 14
								057 - 060	Color Macro 15
								061 - 064	Color Macro 16
								065 - 068	Color Macro 17
								069 - 072	Color Macro 18
								073 - 076	Color Macro 19
								077 - 080	Color Macro 20
								081 - 084	Color Macro 21
								085 - 088	Color Macro 22
								089 - 092	Color Macro 23
								093 - 096	Color Macro 24
								097 - 100	Color Macro 25
								101 - 104	Color Macro 26
								105 - 108	Color Macro 27
								109 - 112	Color Macro 28
								113 - 116	Color Macro 29
								117 - 120	Color Macro 30
								121 - 124	Color Macro 31
								125 - 128	Color Macro 32
							129 - 132	Color Macro 33	
							133 - 136	Color Macro 34	

CONTINUED ON NEXT PAGE

## DMX TRAITS

CHANNEL								DMX VALUES	FUNCTION	
3-CH	4-CH	6-CH	7-CH	8-CH	8A-CH	10-CH	11-CH			
1									<i>Color Macros (continued)</i>	
								137 - 140	Color Macro 35	
									141 - 144	Color Macro 36
									145 - 148	Color Macro 37
									149 - 152	Color Macro 38
									153 - 156	Color Macro 39
									157 - 160	Color Macro 40
									161 - 164	Color Macro 41
									165 - 168	Color Macro 42
									169 - 172	Color Macro 43
									173 - 176	Color Macro 44
									177 - 180	Color Macro 45
									181 - 184	Color Macro 46
									185 - 188	Color Macro 47
									189 - 192	Color Macro 48
									193 - 196	Color Macro 49
									197 - 200	Color Macro 50
									201 - 204	Color Macro 51
									205 - 208	Color Macro 52
									209 - 212	Color Macro 53
									213 - 216	Color Macro 54
									217 - 220	Color Macro 55
									221 - 224	Color Macro 56
									225 - 228	Color Macro 57
									229 - 232	Color Macro 58
									233 - 236	Color Macro 59
								237 - 240	Color Macro 60	
								241 - 244	Color Macro 61	
								245 - 248	Color Macro 62	
								249 - 252	Color Macro 63	
								253 - 255	Color Macro 64	
	1	1	1	1	1	1	1	000 - 255	<b>Red</b> , 0% to 100%	
					2			000 - 255	<b>Red Fine</b> , 0% to 100%	
	2	2	2	2	3	2	2	000 - 255	<b>Green</b> , 0% to 100%	
					4			000 - 255	<b>Green Fine</b> , 0% to 100%	
	3	3	3	3	5	3	3	000 - 255	<b>Blue</b> , 0% to 100%	

CONTINUED ON NEXT PAGE

## DMX TRAITS

CHANNEL								DMX VALUES	FUNCTION
3-CH	4-CH	6-CH	7-CH	8-CH	8A-CH	10-CH	11-CH		
					6			000 - 255	<b>Blue Fine</b> , 0% to 100%
	4	4	4	4	7	4	4	000 - 255	<b>Amber</b> , 0% to 100%
					8			000 - 255	<b>Amber Fine</b> , 0% to 100%
2			5	5		5	5		<b>Shutter/Strobe</b>
								000 - 031	LED Off
								032 - 063	LED On
								064 - 095	Strobe Effect, slow to fast
								096 - 127	LED On
								128 - 159	Strobe Pulse, slow to fast
								160 - 191	LED On
								192 - 223	Random Strobe, slow to fast
224 - 255	LED On								
3		5	6	6		6	6	000 - 255	<b>Master Dimmer</b> , 0% to 100%
		6	7	7		7	7	000 - 255	<b>Master Dimmer Fine</b> , 0% to 100%
				8			11		<b>Dimmer Modes</b>
								000 - 020	Standard
								021 - 040	Stage
								041 - 060	TV
								061 - 080	Architectural
								081 - 100	Theater
								101 - 120	Stage 2
121 - 255	Default to unit setting								
						8	8		<b>Ch9 Modes</b>
								000 - 051	Standard Dim Mode
								062 - 102	Engage CH9 Color Macro Mode
								103 - 153	Engage CH9 Color Jump Mode
								154 - 204	Engage CH9 Color Dream Mode
205 - 255	Engage CH9 Sound Mode								
						9	9		<b>Color Jump Mode</b>
								000 - 015	Color Jump 1
								016 - 031	Color Jump 2
								032 - 047	Color Jump 3
								048 - 063	Color Jump 4
								064 - 079	Color Jump 5
								080 - 095	Color Jump 6
096 - 111	Color Jump 7								

CONTINUED ON NEXT PAGE

## DMX TRAITS

CHANNEL								DMX VALUES	FUNCTION
3-CH	4-CH	6-CH	7-CH	8-CH	8A-CH	10-CH	11-CH		
									<b><i>Color Jump Mode (continued)</i></b>
								112 - 127	Color Jump 8
								128 - 143	Color Jump 9
								144 - 159	Color Jump 10
								160 - 175	Color Jump 11
								176 - 191	Color Jump 12
								192 - 207	Color Jump 13
								208 - 223	Color Jump 14
								224 - 239	Color Jump 15
								240 - 255	Color Jump 16
									<b><i>Color Dream Mode</i></b>
								000 - 015	Color Dream 1
								016 - 031	Color Dream 2
								032 - 047	Color Dream 3
								048 - 063	Color Dream 4
								064 - 079	Color Dream 5
								080 - 095	Color Dream 6
						9	9	096 - 111	Color Dream 7
								112 - 127	Color Dream 8
								128 - 143	Color Dream 9
								144 - 159	Color Dream 10
								160 - 175	Color Dream 11
								176 - 191	Color Dream 12
								192 - 207	Color Dream 13
								208 - 223	Color Dream 14
								224 - 239	Color Dream 15
								240 - 255	Color Dream 16
									<b><i>Color Macro Mode</i></b>
								000	Off
								001 - 004	Color Macro 01
								005 - 008	Color Macro 02
								009 - 012	Color Macro 03
								013 - 016	Color Macro 04
								017 - 020	Color Macro 05
								021 - 024	Color Macro 06
								025 - 028	Color Macro 07

CONTINUED ON NEXT PAGE



## DMX TRAITS

CHANNEL								DMX VALUES	FUNCTION
3-CH	4-CH	6-CH	7-CH	8-CH	8A-CH	10-CH	11-CH		
									<i>Color Macro Mode (continued)</i>
								029 - 032	Color Macro 08
								033 - 036	Color Macro 09
								037 - 040	Color Macro 10
								041 - 044	Color Macro 11
								045 - 048	Color Macro 12
								049 - 052	Color Macro 13
								053 - 056	Color Macro 14
								057 - 060	Color Macro 15
								061 - 064	Color Macro 16
								065 - 068	Color Macro 17
								069 - 072	Color Macro 18
								073 - 076	Color Macro 19
								077 - 080	Color Macro 20
								081 - 084	Color Macro 21
								085 - 088	Color Macro 22
								089 - 092	Color Macro 23
						9	9	093 - 096	Color Macro 24
								097 - 100	Color Macro 25
								101 - 104	Color Macro 26
								105 - 108	Color Macro 27
								109 - 112	Color Macro 28
								113 - 116	Color Macro 29
								117 - 120	Color Macro 30
								121 - 124	Color Macro 31
								125 - 128	Color Macro 32
								129 - 132	Color Macro 33
								133 - 136	Color Macro 34
								137 - 140	Color Macro 35
								141 - 144	Color Macro 36
								145 - 148	Color Macro 37
								149 - 152	Color Macro 38
								153 - 156	Color Macro 39
								157 - 160	Color Macro 40
								161 - 164	Color Macro 41
								165 - 168	Color Macro 42

CONTINUED ON NEXT PAGE

## DMX TRAITS

CHANNEL								DMX VALUES	FUNCTION
3-CH	4-CH	6-CH	7-CH	8-CH	8A-CH	10-CH	11-CH		
									<b><i>Color Macro Mode (continued)</i></b>
								169 - 172	Color Macro 43
								173 - 176	Color Macro 44
								177 - 180	Color Macro 45
								181 - 184	Color Macro 46
								185 - 188	Color Macro 47
								189 - 192	Color Macro 48
								193 - 196	Color Macro 49
								197 - 200	Color Macro 50
								201 - 204	Color Macro 51
								205 - 208	Color Macro 52
								209 - 212	Color Macro 53
								213 - 216	Color Macro 54
								217 - 220	Color Macro 55
								221 - 224	Color Macro 56
								225 - 228	Color Macro 57
								229 - 232	Color Macro 58
						9	9	233 - 236	Color Macro 59
								237 - 240	Color Macro 60
								241 - 244	Color Macro 61
								245 - 248	Color Macro 62
								249 - 252	Color Macro 63
								253 - 255	Color Macro 64
									<b><i>Sound Mode</i></b>
								000 - 015	Sound Active 1
								016 - 031	Sound Active 2
								032 - 047	Sound Active 3
								048 - 063	Sound Active 4
								064 - 079	Sound Active 5
								080 - 095	Sound Active 6
								096 - 111	Sound Active 7
								112 - 127	Sonud Active 8
								128 - 143	Sound Active 9
								144 - 159	Sound Active 10
								160 - 175	Sound Active 11
								176 - 191	Sound Active 12

CONTINUED ON NEXT PAGE

## DMX TRAITS

CHANNEL								DMX VALUES	FUNCTION
3-CH	4-CH	6-CH	7-CH	8-CH	8A-CH	10-CH	11-CH		
									<b><i>Sound Mode (continued)</i></b>
						9	9	192 - 207	Sound Active 13
								208 - 223	Sound Active 14
								224 - 239	Sound Active 15
								240 - 255	Sound Active 16
									<b><i>Color Jump/Dream Modes Speed</i></b>
								000 - 255	Speed, slow to fast
						10	10		<b><i>Sound Mode Sensitivity</i></b>
								000 - 031	Off
								032 - 255	Sensitivity, high to low

# DIMMER CURVE CHART

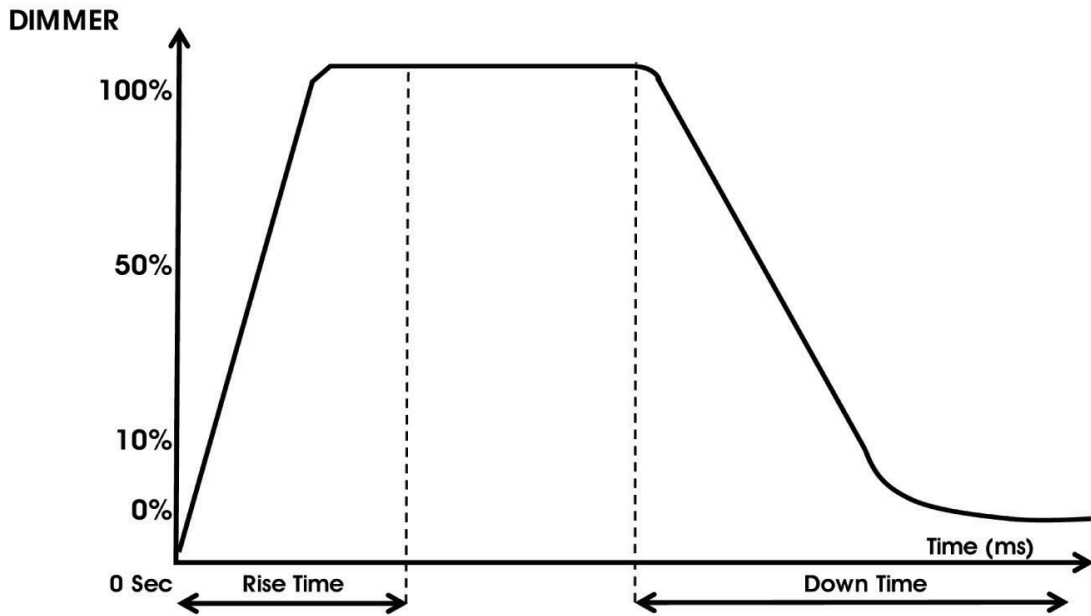

Dimming Curve Ramp Effect	0 sec Fade Time		1 sec Fade Time	
	Rise Time (ms)	Down Time (ms)	Rise Time (ms)	Down Time (ms)
Standard (default)	0	0	0	0
Stage	780	1100	1540	1660
TV	1180	1520	1860	1940
Architectural	1380	1730	2040	2120
Theatre	1580	1940	2230	2280
Stage 2	0	1100	0	1660

## **MULTIPLE UNIT POWER LINKING**

With this feature you can connect the fixtures to one another using the power cable input and output sockets.

**A MAXIMUM OF THREE (3) UNITS CAN BE LINKED IN THIS WAY! AFTER THIS VALUE HAS BEEN REACHED, ADDITIONAL UNITS MUST BE CONNECTED TO A SEPARATE OUTLET.**

**NOTE: USE CAUTION WHEN POWER LINKING FIXTURES OF OTHER MODEL TYPES, AS THE POWER CONSUMPTION OF OTHER MODEL FIXTURES MAY EXCEED THE MAX POWER OUTPUT ON THIS FIXTURE! CHECK SILK SCREEN FOR MAX AMPS.**

### **Primary-Secondary Setup**

1. Daisy chain your units via the XLR connectors on the rear of the unit. Use standard XLR data cables to link your units together. Remember that the Male XLR connector is the input and the Female XLR connector is the output. The first unit in the chain (primary) will use the female XLR connector only, and the last unit in the chain will use the male XLR connector only.
2. Set the "Primary" unit to your desired mode of operation.
3. On the "Secondary" units, press the MODE button until "SEcd" is displayed. Each "secondary" unit must be set to the same setting.
4. Connect the first "Secondary" unit to the "Primary." The "Secondary" unit(s) should now start following the "Primary" unit.

## CLEANING AND MAINTENANCE

### FUSE REPLACEMENT

Disconnect the unit from its power source, and remove the power cord from the unit. Use a Phillips head screwdriver to remove the fuse holder, which is located under the power connection. Remove the fuse located inside the fuse holder and replace with the new fuse. Install the fuse holder and new fuse and secure it back in place.

### CLEANING

Due to fog residue, smoke, and dust, cleaning the internal and external optical lenses must be carried out periodically to optimize light output.

- Use normal glass cleaner and a soft cloth to wipe down the outside casing.
- Clean the external optics with glass cleaner and a soft cloth every 20 days.
- Always be sure to dry all parts completely before plugging the unit back in.

Cleaning frequency depends on the environment in which the fixture operates (i.e. smoke, fog residue, dust, dew).

## TROUBLE SHOOTING TIPS

### Unit does not turn on:

- Confirm the unit has AC power.
- Check if circuit breaker that controls the AC outlet plug has not been tripped.
- Confirm the AC power cord from the light is not damaged or cut.
- Check the fuse and see if it needs to be replaced.
- If none of these solutions work, please contact ADJ Customer Service.

### Unit does not respond to DMX:

Check that the DMX cables are connected and wired correctly (pin 3 is “hot”; on some other DMX devices pin 2 may be ‘hot’). Also, check that all cables are connected to the right connectors; the order in which the inputs and outputs are connected does make a difference.

### Unit does not respond to sound:

- Quiet or high-pitched sounds will not activate the unit.
- Make sure that Sound Active mode is activated.

## FREQUENTLY ASKED QUESTIONS

### Can you use barn doors with the COB Cannon Wash ST?

Yes, barn doors (BAR001) are an optional accessory and can be purchased separately.

### What is the light output in lux?

996 LUX @ 2M; 238 LUX @4M (80-degree), 1472 LUX @2M; 373 LUX @4M (50-degree), 1970 LUX @2M; 474 LUX @4M (40-degree).

### Is the COB Cannon Wash ST flicker free?

Yes, the COB Cannon Wash ST features Flicker Free operation. At 1,000Hz, there should be no flickering on camera.

### How many fixtures can be daisy chained together?

Up to 3 COB Cannon Wash ST units can be daisy chained together. (After 3 fixtures you will need to use a new power outlet.) Use caution when power linking other model fixtures as the power consumption of other model fixtures may exceed the max power output on this fixture. Check Silk Screen for Max Amps.

## OPTIONAL ACCESSORIES

Order Code	Description
AC5PDMX3	3-foot DMX cable with 5-pin male to 5-pin female connection*
AC5PDMX3PRO	Pro Series 3-foot DMX cable with 5-pin male to 5-pin female connection*
S-Cable/60	Safety Cable with 60-pound weight rating
O-CLAMP	360 degree clamp that wraps around truss tubing
PRO-CLAMP	360 degree aluminum clamp with a max rating of 1100 lbs
<i>* Additional lengths available at <a href="http://www.adj.com">www.adj.com</a></i>	

## SPECIFICATIONS

<b>Model</b>	<b>COB Cannon Wash ST / Pearl</b>
<b>Power Draw</b>	150W, 1.2A @ 120V/60Hz 148W, 0.7A @ 220V/50Hz
<b>Light Source</b>	150W RGBA 4-in-1 COB LED source
<b>Voltage</b>	100V ~ 240V/50~60Hz
<b>Beam Angle</b>	80 Degrees (Optional 40-degree and 50-degree lenses included)
<b>Working Position</b>	Any safe working position
<b>Power Cord Daisy Chain</b>	3 fixtures max.
<b>Fuse</b>	3 Amp
<b>Colors</b>	Cool White & Warm White Mixing
<b>DMX Channels</b>	8 DMX Modes: 3-, 4-, 6-, 7-, 8-, 8A-, 10-, and 11-channel modes
<b>Dimming</b>	0-100% electronic dimming
<b>Strobe Flash Rate (Hz)</b>	0.65Hz - 11Hz
<b>Flicker Free</b>	Yes, 1000Hz
<b>IP Rating</b>	IP20 (indoor use only)
<b>Weight</b>	9.26 lbs / 4.2 Kgs
<b>Dimensions (w/ bracket)</b>	13" (L) x 10" (W) x 7.5" (H) 330mm x 256mm x 190mm
<b>Dimensions (w/o bracket)</b>	8.75" (L) x 7.5" (W) x 7.5" (H) 218mm x 190mm x 190mm
<b>Warranty</b>	2 Years (730 Days)

**Please Note:** Specifications and improvements in the design of this unit and this manual are subject to change without any prior written notice.



# DIMENSIONAL DRAWINGS

