

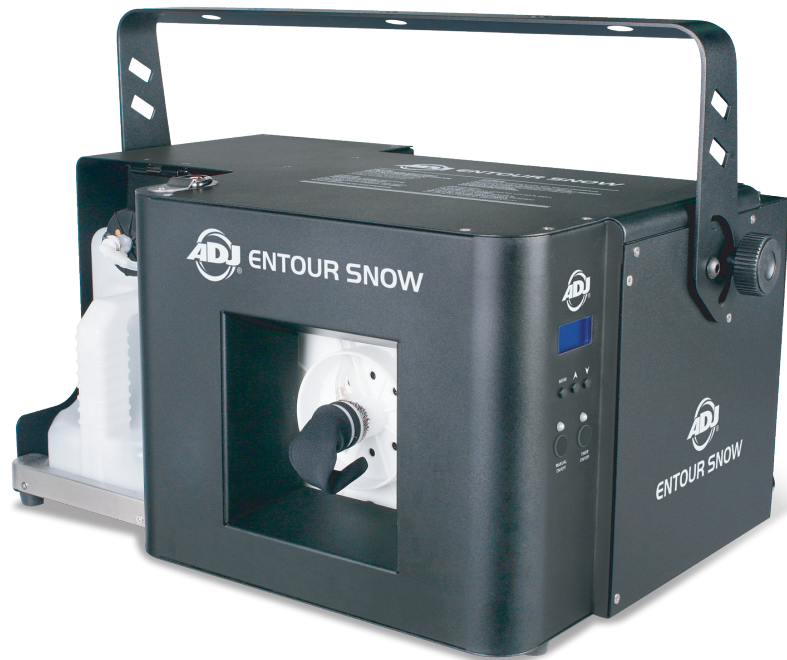

ENTOUR SNOW



User Instructions

©2017 ADJ Products, LLC all rights reserved. Information, specifications, diagrams, images, and instructions herein are subject to change without notice. ADJ Products, LLC logo and identifying product names and numbers herein are trademarks of ADJ Products, LLC. Copyright protection claimed includes all forms and matters of copyrightable materials and information now allowed by statutory or judicial law or hereinafter granted. Product names used in this document may be trademarks or registered trademarks of their respective companies and are hereby acknowledged. All non-ADJ Products, LLC brands and product names are trademarks or registered trademarks of their respective companies.

ADJ Products, LLC and all affiliated companies hereby disclaim any and all liabilities for property, equipment, building, and electrical damages, injuries to any persons, and direct or indirect economic loss associated with the use or reliance of any information contained within this document, and/or as a result of the improper, unsafe, insufficient and negligent assembly, installation, rigging, and operation of this product.

DOCUMENT VERSION

Please check www.adj.com for the latest revision/update of this guide.

Date	Document Version	Software Version ≥	DMX Channel Mode	Notes
10/24/17	1	1.01	1/3/5	Initial Release

Europe Energy Saving Notice
Energy Saving Matters (EuP 2009/125/EC)
Saving electric energy is a key to help protecting the environment. Please turn off all electrical products when they are not in use. To avoid power consumption in idle mode, disconnect all electrical equipment from power when not in use. Thank you!

Introduction: Congratulations, you have just purchased one of the most reliable snow machines on the market today! The Entour Snow machine have been designed to perform reliably for years when the guidelines in this booklet are followed. Please read and understand the instructions in this manual carefully and thoroughly before attempting to operate this unit. These instructions contain important information regarding safety during use and maintenance.

Customer Support: ADJ Products, LLC provides a toll free customer support line, to provide set up help and to answer any question should you encounter problems during your set up or initial operation. You may also visit us on the web at www.adj.com for any comments or suggestions. For service related issue please contact ADJ Products, LLC. Service Hours are Monday through Friday 8:00 a.m. to 4:30 p.m. Pacific Standard Time.

Voice: (800) 322-6337

Fax: (323) 582-2941

E-mail: support@americandj.com

To purchase parts online visit <http://parts.americandj.com>

Warning! To prevent or reduce the risk of electrical shock or fire, do not expose this unit to rain or moisture.

Caution! There are no user serviceable parts inside this unit. Do not attempt any repairs yourself, doing so will void your manufactures warranty. In the unlikely event your unit may require service please contact ADJ Products, LLC.

Do not discard the shipping cartoon in the trash. Please recycle when ever possible.

SAFETY ISSUES:

NEVER POINT OR AIM A SNOW MACHINE TOWARDS PEOPLE OR THEIR CLOTHING.

Please Note: Specifications and improvements in the design of this unit and this manual are subject to change without any prior written notice.

- Be sure to save the packing carton in the unlikely event the unit may have to be returned for service
- Do not spill water or other liquids into or on to your fazer. Be sure that all the snow fluid is kept inside the fluid reservoir
- Be sure that the local power outlet match that or the required voltage for your snow machine
- Do not remove the top cover under any conditions. There are no user serviceable parts inside
- Disconnect the unit's main power when left unused for long periods of time
- Never connect this unit to a dimmer pack
- Do not attempt to operate this unit, if it becomes damaged in anyway
- Never operate this unit when it's cover is removed
- To reduce the risk of electrical shock or fire, do not expose this unit rain or moisture
- Do not attempt to operate this unit if the power cord has been frayed or broken. Do not attempt to remove or break off the ground prong from the electrical cord. This prong is used to reduce the risk of electrical shock and fire in case of an internal short
- Disconnect from main power before making any type of connection
- Never block the ventilation holes. Always be sure to mount this unit in an area that will allow proper ventilation. Allow about 6" (15cm) between this device and a wall
- This unit is intended for indoor use only, use of this product outdoors voids all warranties
- Always mount this unit in a safe and stable matter
- Please route your power cord out of the way of foot traffic. Power cords should be routed so they are not likely to be walked on, pinched by items placed upon or against them
- The unit should only be serviced by qualified service personnel when:
 - A. The power-supply cord or the plug has been damaged.
 - B. Objects have fallen, or liquid has been spilled into the unit.
 - C. The unit has been exposed to rain or water.
 - D. The appliance does not appear to operate normally or exhibits a marked change in performance.

Power Supply: Before plugging your unit in, be sure the source voltage in your area matches the required voltage for your ADJ Entour Snow. The ADJ Entour Snow is available in a 120v and 240v version. Because line voltage may vary from venue to venue, you should be sure your unit voltage matches the wall outlet voltage before attempting to operate you fixture.

DMX-512: DMX is short for Digital Multiplex. This is a universal protocol used as a form of communication between intelligent fixtures and controllers. A DMX controller sends DMX data instructions from the controller to the fixture. DMX data is sent as serial data that travels from fixture to fixture via the DATA “IN” and DATA “OUT” XLR terminals located on all DMX fixtures (most controllers only have a DATA “OUT” terminal).

DMX Linking: DMX is a language allowing all makes and models of different manufactures to be linked together and operate from a single controller, as long as all fixtures and the controller are DMX compliant. To ensure proper DMX data transmission, when using several DMX fixtures try to use the shortest cable path possible. The order in which fixtures are connected in a DMX line does not influence the DMX addressing. For example; a fixture assigned a DMX address of 1 may be placed anywhere in a DMX line, at the beginning, at the end, or anywhere in the middle. When a fixture is assigned a DMX address of 1, the DMX controller knows to send DATA assigned to address 1 to that unit, no matter where it is located in the DMX chain.

Data Cable (DMX Cable) Requirements (For DMX Operation):

The Entour Snow can be controlled via DMX-512 protocol. The Entour Snow has 3 DMX channel modes, 1 channel, 3 channel, and 5 channel. The DMX address is set on the back panel. Your unit and your DMX controller require a standard 3-pin XLR connector for data input and data output (Figure 1). We recommend Accu-Cable DMX cables. If you are making your own cables, be sure to use standard 110-120 Ohm shielded cable (This cable may be purchased at almost all pro lighting stores). Your cables should be made with a male and female XLR connector on either end of the cable. Also remember that DMX cable must be daisy chained and cannot be split.



Figure 1

Notice: Be sure to follow figures two and three when making your own cables. Do not use the ground lug on the XLR connector. Do not connect the cable’s shield conductor to the ground lug or allow the shield conductor to come in contact with the XLR’s outer casing. Grounding the shield could cause a short circuit and erratic behavior.

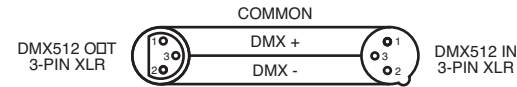

Figure 2

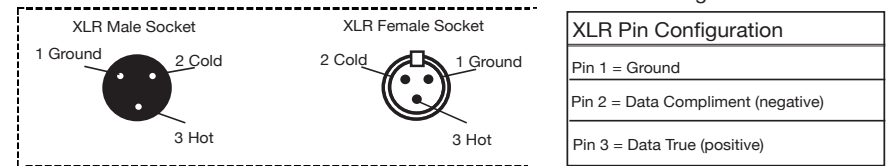

Figure 3

XLR Pin Configuration	
Pin 1 =	Ground
Pin 2 =	Data Compliment (negative)
Pin 3 =	Data True (positive)

Special Note: Line Termination. When longer runs of cable are used, you may need to use a terminator on the last unit to avoid erratic behavior. A terminator is a 110-120 ohm 1/4 watt resistor which is connected between pins 2 and 3 of a male XLR connector (DATA + and DATA -). This unit is inserted in the female XLR connector of the last unit in your daisy chain to terminate the line. Using a cable terminator (ADJ part number Z-DMX/T) will decrease the possibilities of erratic behavior.



Termination reduces signal errors and avoids signal transmission problems and interference. It is always advisable to connect a DMX terminal. (Resistance 120 Ohm 1/4 W) between PIN 2 (DMX-) and PIN 3 (DMX +) of the last fixture.

Figure 4

5-Pin XLR DMX Connectors. Some manufactures use 5-pin DMX-512 data cables for DATA transmission in place of 3-pin. 5-pin DMX fixtures may be implemented in a 3-pin DMX line. When inserting standard 5-pin data cables in to a 3-pin line a cable adaptor must be used, these adaptors are readily available at most electric stores. The chart below details a proper cable conversion.

3-Pin XLR to 5-Pin XLR Conversion		
Conductor	3-Pin XLR Female (Out)	5-Pin XLR Male (In)
Ground/Shield	Pin 1	Pin 1
Data Compliment (- signal)	Pin 2	Pin 2
Data True (+ signal)	Pin 3	Pin 3
Not Used		Do Not Use
Not Used		Do Not Use

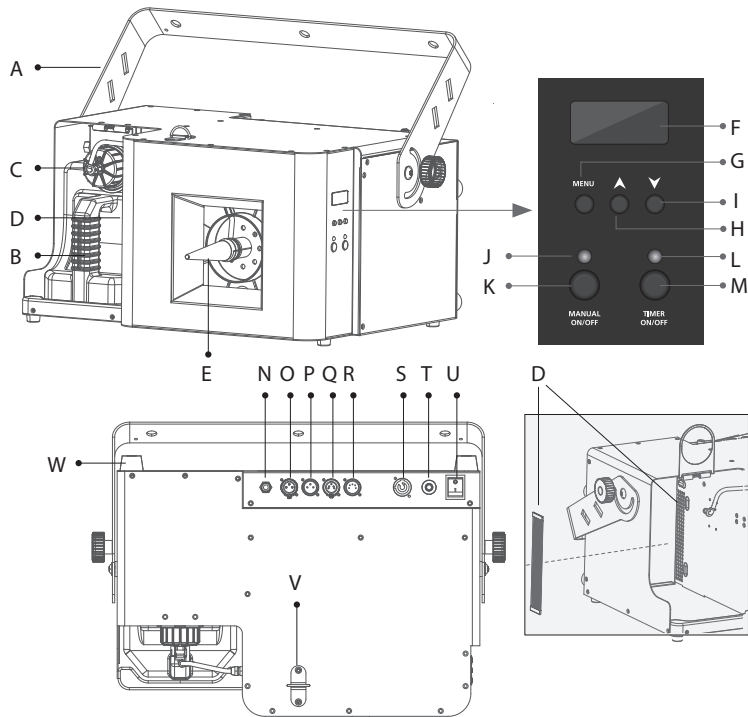

- | | |
|--|-------------------------------|
| A. Hanging Bracket with handle screw (could be done as a tripod) | L. Timer ON/OFF LED Indicator |
| B. Unique Anti-Spill Tank | M. Timer ON/OFF |
| C. Quick Connector | N. Control Socket Connection |
| D. Inlet with Magnetic air filter | O. DMX 3 PIN XLR Output |
| E. Snow Nozzle with cloth | P. DMX 3 PIN XLR Input |
| F. LCD display | Q. DMX 5 PIN XLR Output |
| G. MENU | R. DMX 5 PIN XLR Input |
| H. UP | S. Power Input |
| I. DOWN | T. NFB (No Fuse Breaker) |
| J. Manual ON/OFF LED Indicator | U. Power Switch |
| K. Manual ON/OFF | V. Suspension/Safety Ring |
| | W. Pad |

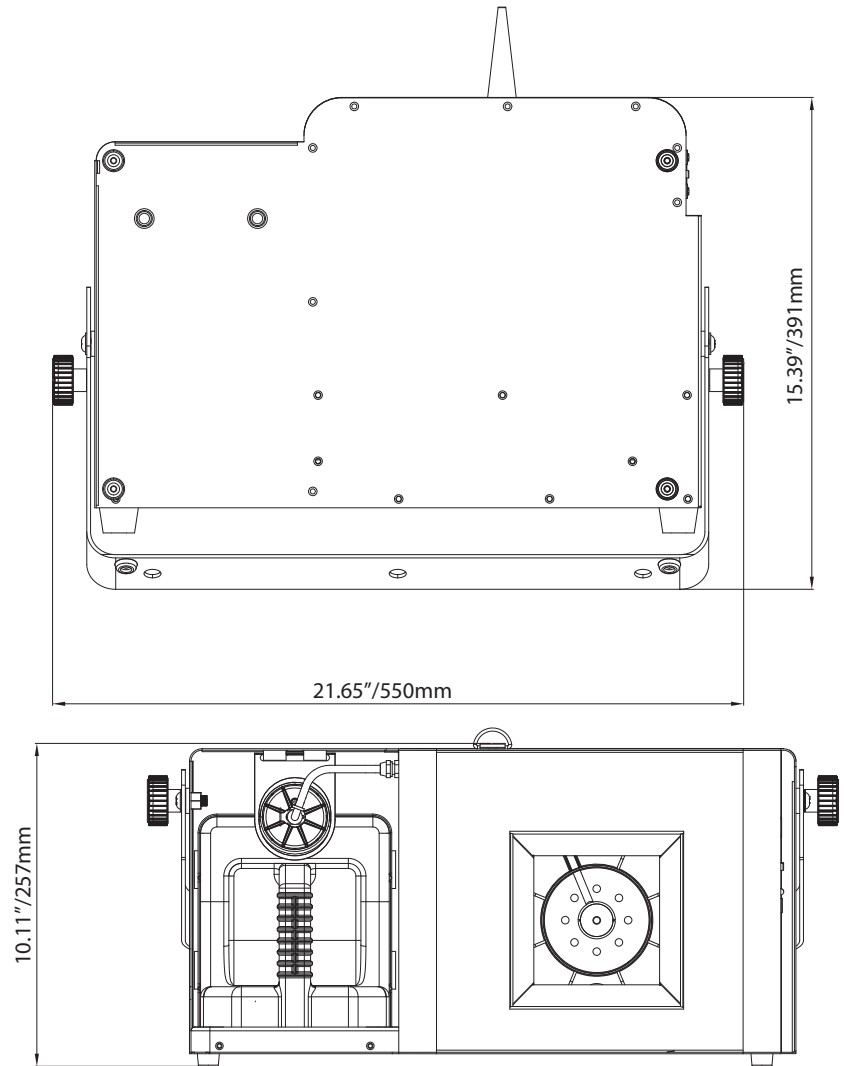

1. Open the shipping carton and carefully remove the unit from the shipping carton.
2. Be sure to remove all the packing material especially around the snow outlet.
3. Set the machine on a flat dry surface and fill the fluid reservoir with American DJ brand snow fluid. Place the feeder tube with the filter deep inside the reservoir and tighten the cap.
4. Plug the unit into a matching power supply.
5. Follow the operating instructions on the next pages for proper operation.



MENU BUTTON - Press this button to cycle between manual mode, DMX channel mode, and DMX addressing. Use the UP and DOWN buttons to adjust the DMX address and change the DMX channel mode.

UP BUTTON - Use this button to switch between DMX channel modes and adjust the DMX address. This button is also used to adjust the fan output snow output, interval time, and duration time.

DOWN BUTTON - Use this button to switch between DMX channel modes and adjust the DMX address. This button is also used to adjust the fan output snow output, interval time, and duration time.

MANUAL BUTTON - Press this button to manually control snow output.

TIMER ON/OFF BUTTON - Press this button to activate the timer function.

TIMER OPERATION: When using this function a DMX controller cannot be connected.

1. Press the MENU button to scroll through snow output setting, wind setting, interval setting and duration setting.
2. When “SNOW” is displayed you can use the UP or DOWN buttons to adjust the amount of snow output. It can be adjusted between 1-100 or AUTO, which is random amount of output. To set the unit to AUTO press the UP button until you get to 100 and press the UP button again to display “SNOW AUTO”.
3. Press the MENU button again to adjust the “WIND” output. Use the UP or DOWN buttons to adjust between “50%”, “100%”, or “AUTO” (Random). After you have found your desired setting press the MENU button to adjust the interval.
4. Use the UP or DOWN buttons to adjust interval (pause) time, between 20s-2000s. Once you have your desired setting, press the MENU button to adjust duration.
5. Use the UP or DOWN buttons to adjust duration (output) time, between 10s-200s. Press the MENU button again to return to the home screen.
6. Press the TIMER button to activate the timer function. Press the TIMER button again to deactivate the timer function.

MANUAL OPERATION:

1. Press the MENU button to scroll through snow output setting, and (wind) fan setting. Interval and duration are not used with manual operation.
2. When “SNOW” is displayed you can use the UP or DOWN buttons to adjust the amount of snow output. It can be adjusted between 1-100 or AUTO, which is random amount of output. To set the unit to AUTO press the UP button until you get to 100 and press the UP button again to display “SNOW AUTO”.
3. Press the MENU button again to adjust the “WIND” output. Use the UP or DOWN buttons to adjust between “50%”, “100%”, or “AUTO” (Random). After you have found your desired setting press the MENU button to adjust the interval.
4. Press the MANUAL ON/OFF button to activate the snow output. Press the MANUAL ON/OFF button again to deactivate stop output.

Entour Snow **DMX Mode**

DMX Mode:

The Entour Snow has 3 DMX channel modes; 1 channel mode, 3 channel mode, and 5 channel mode. See page 13 for the DMX traits.

1. This function will allow you to control the unit with a standard DMX 512 controller.
2. Press the MENU button until “DMX ADDR” is displayed. Use the UP or DOWN buttons to find your desired DMX address.
3. Once you have set your DMX address press the MENU button until “DMX MODE” is displayed. Use the UP or DOWN buttons to find your desired DMX channel mode.
4. Please see this page and the next for DMX values and traits.
5. After you have chosen your desired DMX Channel mode plug in the fixture via the XLR connections to any standard DMX controller.

Entour Snow		1 Channel Mode
Channel	Value	Function
1	0 - 249 250 - 255	OUTPUT VOLUME 0%-100% OUTPUT AUTO RANDOM SHOW

Note: The Wind (fan) speed needs to be set using the control panel.

Entour Snow		3 Channel Mode
Channel	Value	Function
1	0 - 249 250 - 255	OUTPUT VOLUME 0%-100% OUTPUT AUTO RANDOM SHOW
2	0 - 124 125 - 249 250 - 255	FAN SPEED 50% FAN SPEED 100% FAN SPEED AUTO RANDOM SPEED
3	0 - 127 128 - 255	SNOW ON/OFF SNOW OFF SNOW ON

Entour Snow		5 Channel Mode
Channel	Value	Function
1	0 - 249 250 - 255	OUTPUT VOLUME 0%-100% OUTPUT AUTO RANDOM SHOW
2	0 - 124 125 - 249 250 - 255	FAN SPEED 50% FAN SPEED 100% FAN SPEED AUTO RANDOM SPEED
3	0 - 127 128 - 255	SNOW ON/OFF SNOW OFF SNOW ON
4	0 - 255	DURATION 0-255 SECONDS
5	0 - 255	INTERVAL 0-2550 SECONDS

Entour Snow

Maintenance

The fluid cannot get dirty. Always make sure the cap is clean and the snow fluid line. Periodically nozzle maybe come clogged by impurities contact ADJ customer service for a replacement nozzle.

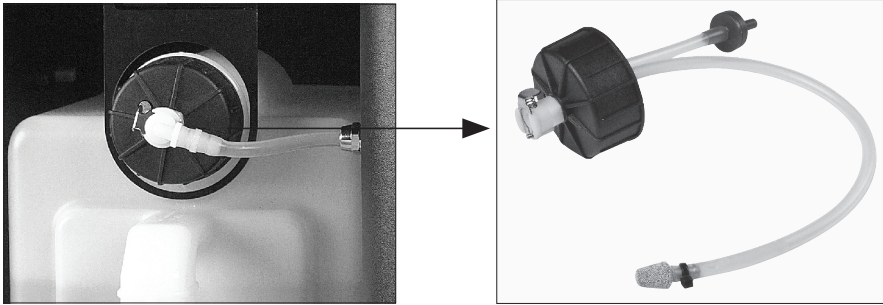

With prolonged use, the air filter can accumulate dust. Periodically remove the fluid tank by unscrewing the cap. Lift up the tank holder, remove the tank and remove the magnetic air filter to clean. After cleaning, be sure to dry the air filter, and reinstall the filter. If you would like to replace the air filter, contact ADJ customer service.

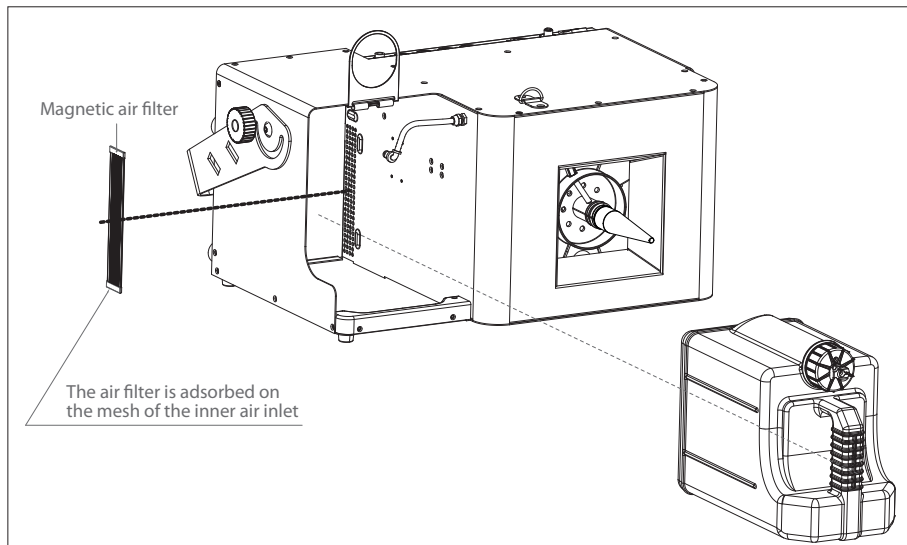

Entour Snow

Maintenance

To remove the cloth and spring carefully snip the black zip tie that secures the cloth in the place. Try not to cut through the cloth. Remove the cloth and and spring. Clean cloth and spring and reinstall with zip tie security.

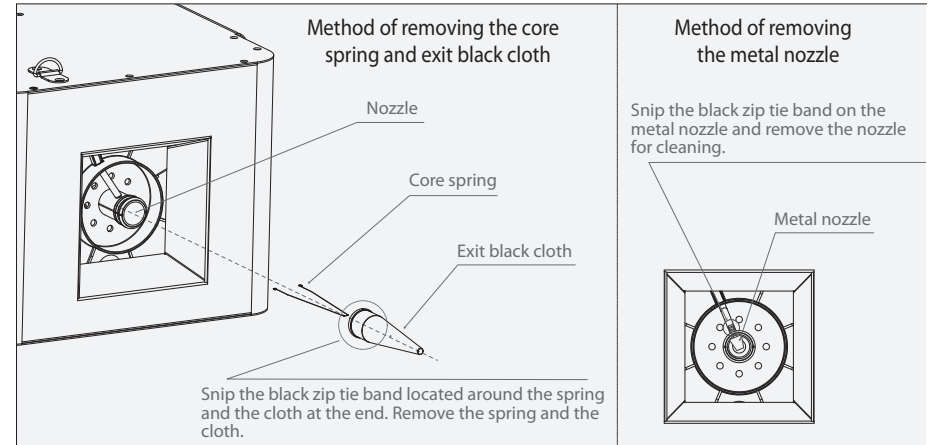

Entour Snow

Warranty Registration

The Entour Snow machine carries a one year (365 days) limited warranty. Please fill out the enclosed warranty card to validate your purchase. All returned service items whether under warranty or not, must be freight pre-paid and accompany a return authorization (R.A.) number. The R.A. number must be clearly written on the outside of the return package. A brief description of the problem as well as the R.A. number must also be written down on a piece of paper and included in the shipping container. If the unit is under warranty, you must provide a copy of your proof of purchase invoice. You may obtain a R.A. number by contacting customer support at (800) 322-6337.

Entour Snow

Storage

When storing your machine be sure to store it in a cool area. Cover the machine so that dust does not build up on the unit. When storing the machine for long periods of time, it is highly advised to at least run the machine every 3-4 months. Long periods of inactivity can severely shorten the life of your machine. Only run water based snow juice through your machine. Never run plain water, vinegar, or any other liquid solution through your machine. Running anything other than water based snow juice will severely damage your machine.

Entour Snow

Warranty

MANUFACTURER'S LIMITED WARRANTY

- A. ADJ Products, LLC hereby warrants, to the original purchaser, ADJ Products, LLC products to be free of manufacturing defects in material and workmanship for a prescribed period from the date of purchase (see specific warranty period on reverse). This warranty shall be valid only if the product is purchased within the United States of America, including possessions and territories. It is the owner's responsibility to establish the date and place of purchase by acceptable evidence, at the time service is sought.
- B. For warranty service you must obtain a Return Authorization number (RA#) before sending back the product—please contact ADJ Products, LLC Service Department at 800-322-6337. Send the product only to the ADJ Products, LLC factory. All shipping charges must be pre-paid. If the requested repairs or service (including parts replacement) are within the terms of this warranty, ADJ Products, LLC will pay return shipping charges only to a designated point within the United States. If the entire instrument is sent, it must be shipped in its original package. No accessories should be shipped with the product. If any accessories are shipped with the product, ADJ Products, LLC shall have no liability whatsoever for loss of or damage to any such accessories, nor for the safe return thereof.
- C. This warranty is void if the serial number has been altered or removed; if the product is modified in any manner which ADJ Products, LLC concludes, after inspection, affects the reliability of the product; if the product has been repaired or serviced by anyone other than the ADJ Products, LLC factory unless prior written authorization was issued to purchaser by ADJ Products, LLC; if the product is damaged because not properly maintained as set forth in the instruction manual.
- D. This is not a service contract, and this warranty does not include maintenance, cleaning or periodic check up. During the period specified above, ADJ Products, LLC will replace defective parts at its expense with new or refurbished parts, and will absorb all expenses for warranty service and repair labor by reason of defects in material or workmanship. The sole responsibility of ADJ Products, LLC under this warranty shall be limited to the repair of the product, or replacement thereof, including parts, at the sole discretion of ADJ Products, LLC. All products covered by this warranty were manufactured after August 15, 2012, and bear identifying marks to that effect.
- E. ADJ Products, LLC reserves the right to make changes in design and/or improvements upon its products without any obligation to include these changes in any products theretofore manufactured.

No warranty, whether expressed or implied, is given or made with respect to any accessory supplied with products described above. Except to the extent prohibited by applicable law, all implied warranties made by ADJ Products, LLC in connection with this product, including warranties of merchantability or fitness, are limited in duration to the warranty period set forth above. And no warranties, whether expressed or implied, including warranties of merchantability or fitness, shall apply to this product after said period has expired. The consumer's and/or Dealer's sole remedy shall be such repair or replacement as is expressly provided above; and under no circumstances shall ADJ Products, LLC be liable for any loss or damage, direct or consequential, arising out of the use of, or inability to use, this product.

This warranty is the only written warranty applicable to ADJ Products, LLC Products and supersedes all prior warranties and written descriptions of warranty terms and conditions heretofore published.

MANUFACTURER'S LIMITED WARRANTY PERIODS:

- **Non L.E.D. Lighting Products = 1-year (365 days) Limited Warranty** (Such as: Special Effect Lighting, Intelligent Lighting, UV lighting, Strobes, Fog Machines, Bubble Machines, Mirror Balls, Par Cans, Trussing, Lighting Stands etc. excluding LED and lamps)
- **Laser Products = 1 Year (365 Days) Limited Warranty** (excluding laser diodes which have a 6 month limited warranty)
- **L.E.D. Products = 2-year (730 days) Limited Warranty** (excluding batteries which have a 180 day limited warranty). **Note: 2 Year Warranty only applies to purchases within the United States.**
- **StarTec Series = 1 Year Limited Warranty** (excluding batteries which have a 180 day limited warranty).
- **ADJ DMX Controllers = 2 Year (730 Days) Limited Warranty**

Entour Snow

Specifications

MODEL - Entour Snow

VOLTAGE*:	120v or 230V, 50/60Hz
POWER CONSUMPTION:	1250W
WEIGHT:	30 Lbs. / 13.5 Kgs
DIMENSIONS:	15.39" x 21.65" x 10.11" 391 x 550 x 257 mm
BREAKER:	NFB 16A (120V) / 9A (230V)
TANK CAPACITY:	5.6 Liter
SNOW DISTANCE:	12M
SNOW HEIGHT:	10M
FLUID CONSUMPTION (ml/min):	500ml/min (Max Output)
FLUID TYPE:	Water Based American DJ Snow Juice
DMX CHANNELS:	3 DMX Channel Modes: 1/3/5

**Voltage is preset at the factory and may not be changed*

ADJ Products, LLC
6122 S. Eastern Ave. Los Angeles, CA 90040 USA
Tel: 323-582-2650 / Fax: 323-725-6100
Web: www.adj.com / E-mail: info@americandj.com

A.D.J. Supply Europe B.V.
Junostraat 2
6468 EW Kerkrade
Netherlands

Follow Us On:



facebook.com/americandj
twitter.com/americandj
youtube.com/adjlighting

support@adjgroup.eu / www.adj.eu
Tel: +31 45 546 85 00 / Fax: +31 45 546 85 99